

PRESSURE UNITS

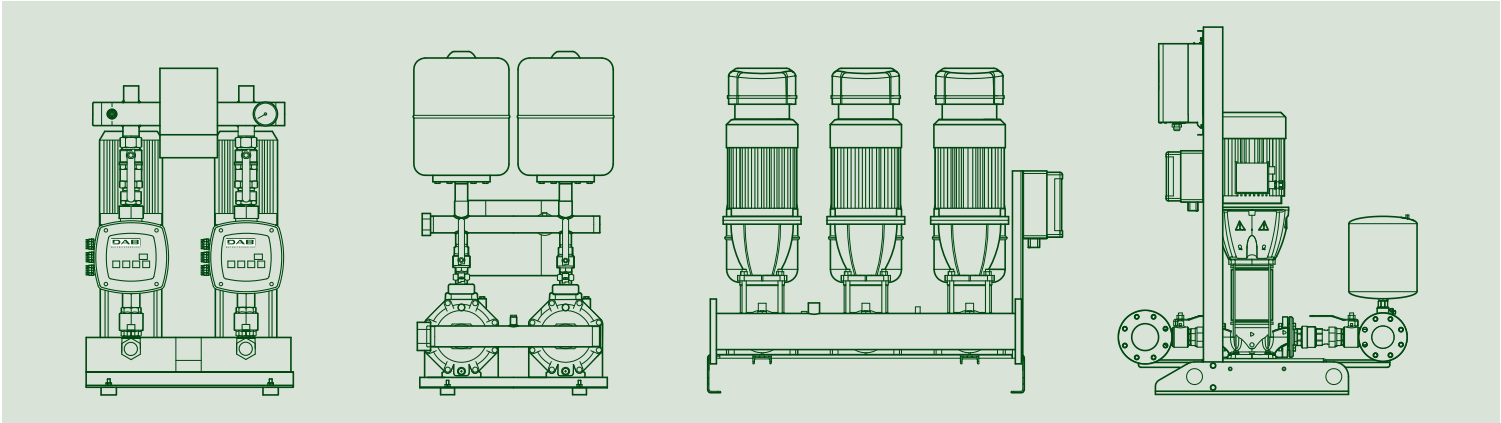

**TECHNICAL
CATALOGUE**



THE INTERNATIONAL CERTIFICATION NETWORK

CERTIFICATE

IQNet and its partner
CISQ/IMQ-CSQ
hereby certify that the organization

DWT HOLDING SPA
VIA MARCO POLO 14 - 35035 MESTRINO (PD)
BRENDOLA (VI) - CASTELLO DI GODEGO (TV) - BIENTINA (PI) -
SAN GERMANO DEI BERICI (VI) - PRC CHINA - HUNGARY

for the following field of activities
*Design, production, sale and assistance of components and electronic controls for pumps, electropumps,
and pump sets for cold and hot water for civil, industrial and agricultural use*
Refer to quality manual for details of applications to ISO 9001:2008 requirements

has implemented and maintains a
Quality Management System
which fulfills the requirements of the following standard
ISO 9001:2008
Issued on: 2015 - 05 - 28 Expiry date: 2018 - 05 - 27

Registration Number: **IT - 824**

The status of validity of the certificate can be verified at <http://www.cisq.com> or by e-mail to fed@cisq.com



Michael Drechsel
 President of IQNET



Ing. Claudio Proveti
 President of CISQ

IQNet Partners*:
AENOR Spain AFNOR Certification France AIB-Vincotte International Belgium ANCE-SIGE Mexico APCER Portugal CCC Cyprus
CISQ Italy CQC China CQM China CQS Czech Republic Cro Cert Croatia DQS Holding GmbH Germany
FCAV Brazil FONDONORMA Venezuela ICONTEC Colombia IMNC Mexico Inspecta Certification Finland IRAM Argentina
JQA Japan KIQ Korea MIRTEC Greece MSST Hungary Nemko AS Norway NSAI Ireland PCBC Poland
Quality Austria Austria RR Russia SII Israel SIQ Slovenia SIRIM QAS International Malaysia
SQS Switzerland SRAC Romania TEST Si Petersburg Russia TSE Turkey YUQS Serbia
IQNet is represented in the USA by: AFNOR Certification, CISQ, DQS Holding GmbH and NSAI Inc.
* The list of IQNet partners is valid at the time of issue of this certificate. Updated information is available under www.iqnet-certification.com



www.imq.it

Al. 1 di 1
Ann. 1 of 1

CISQ is a member of
IQNet
www.iqnet-certification.com

IQNet, the association of the world's first class certification bodies, is the largest provider of management system Certifications in the world. IQNet is composed of more than 30 bodies and counts over 100 subsidiaries all over the globe.

ALLEGATO CERTIFICATO n. 9101.COGE
ANNEX CERTIFICATE

(*) Unità Operative:
(*) Operative Units:

DAB PUMPS SPA
VIA BONANNO PISANO 1 - 56031 BIENTINA (PI)

DAB PUMPS SPA
VIA DEL LAVORO 3 - 36040 SAN GERMANO DEI BERICI (VI)

DAB PUMPS QINGDAO CO. LTD
40 KAITUO ROAD, QINGDAO DEVELOPMENT ZONE - SHANGDONG PROVINCE, PRC CHINA

DAB PUMPS HUNGARY KFT
BUDA ERNO I - 8800 NAGYKANISZA HUNGARY

DATE	PRIMA CERTIFICAZIONE FIRST CERTIFICATION	EMISSIONE CORRENTE CURRENT ISSUE	SCADENZA EXPIRY
	1995-07-17	2015-05-28	2018-05-27

IMQ S.p.A. - VIA QUINTILIANO, 43 - 20138 MILANO

IAF: 18, 19, 29

ACCREDIA

La validità del certificato è subordinata a sorveglianza annuale e esame completo del Sistema di Gestione con periodicità biennale
The validity of the certificate is subjected to annual audit and a re-assessment of the entire Management System within three years

CISQ è la Federazione Italiana di Organismi di Certificazione del sistema di gestione aziendale.
CISQ is the Italian Federation of management system Certification bodies.

FEDERAZIONE CISQ



www.imq.it

CISQ is a member of
IQNet
www.iqnet-certification.com

IQNet, the association of the world's first class certification bodies, is the largest provider of management system Certifications in the world. IQNet is composed of more than 30 bodies and counts over 100 subsidiaries all over the globe.

CERTIFICATO N. 9101.COGE
CERTIFICATE N. 9101.COGE

SI CERTIFICA CHE IL SISTEMA QUALITÀ DI
WE HEREBY CERTIFY THAT THE QUALITY SYSTEM OPERATED BY

DWT HOLDING SPA
VIA MARCO POLO 14 - 35035 MESTRINO (PD)

UNITÀ OPERATIVE
OPERATIVE UNITS

DAB PUMPS SPA
VIA MARCO POLO 14 - 35035 MESTRINO (PD)
DAB PUMPS SPA
VIA EINAUDI 2 - 36040 BRENDOLA (VI)
DAB PUMPS SPA
VIA E. FERMI 6-8-10 - 31030 CASTELLO DI GODEGO (TV)

Vedere gli Allegati per le altre Unità Operative (n° 1 pagina)
View the Annexes for the other Operative Units (n° 1 page)

E' CONFORME ALLA NORMA
IS IN COMPLIANCE WITH THE STANDARD
ISO 9001:2008

PER LE SEGUENTI ATTIVITÀ:
FOR THE FOLLOWING ACTIVITIES

Progettazione, produzione, commercializzazione e assistenza di componenti e controlli elettronici per pompe, elettropompe e gruppi di pompaggio per acqua fredda e calda ad uso civile, industriale ed agricolo
Design, production, sale and assistance of components and electronic controls for pumps, electropumps, and pump sets for cold and hot water for civil, industrial and agricultural use
Refer to quality manual for details of applications to ISO 9001:2008 requirements

IL PRESENTE CERTIFICATO È SOGGETTO AL RISPETTO DEL
REGOLAMENTO PER LA CERTIFICAZIONE DEI SISTEMI DI GESTIONE
THE USE AND THE VALIDITY OF THE CERTIFICATE SHALL SATISFY THE
REQUIREMENTS OF THE RULES FOR CERTIFICATION OF MANAGEMENT SYSTEMS

DATE	PRIMA CERTIFICAZIONE FIRST CERTIFICATION	EMISSIONE CORRENTE CURRENT ISSUE	SCADENZA EXPIRY
	1995-07-17	2015-05-28	2018-05-27

IMQ S.p.A. - VIA QUINTILIANO, 43 - 20138 MILANO

IAF: 18, 19, 29

ACCREDIA

La validità del certificato è subordinata a sorveglianza annuale e esame completo del Sistema di Gestione con periodicità biennale
The validity of the certificate is subjected to annual audit and a re-assessment of the entire Management System within three years

CISQ è la Federazione Italiana di Organismi di Certificazione del sistema di gestione aziendale.
CISQ is the Italian Federation of management system Certification bodies.

FEDERAZIONE CISQ

CONTENTS

ELECTRONIC PRESSURE SETS



2 JET AD

PAGE 3



1/2/3 KV AD 3-6-10

PAGE 15



2 JETINOX AD

PAGE 5



2-3 NKV AD 10-15

PAGE 25



2 EURO AD

PAGE 7



2/3/4 NKVE 10-15-20-32-45 MCE/P

PAGE 30



2 EUROINOX AD

PAGE 9



2 NKVE 10-15-20 ADAC

PAGE 46



1-2-3 KVC AD

PAGE 11



2/3 KVE 3-6-10

PAGE 50

PRESSURE SETS



2 JET

PAGE 57



1-2-3 KVC

PAGE 72



2 EURO

PAGE 59



1/2/3 KV 3-6-10

PAGE 82



2 EUROINOX

PAGE 61



1/2/3/4 NKV

PAGE 93



2 K

PAGE 63



2 NKV 10/15/20 WITH E-BOX

PAGE 114



AQUATWIN TOP

PAGE 66



1/2/3 NKP-G / 1/2/3 K

PAGE 118

HYDRAULIC EFFICIENCY

ACCESSORIES

TECHNICAL APPENDIX

PAGE 145



PAGE 151

PAGE 155

ACTIVE DRIVER PLUS
PAGE 166



TECHNICAL DATA

Operating range: from 0,4 to 14,4 m³/h.

Pumped liquid: clean, free of solids and abrasives, non viscous, non aggressive, non crystallised and chemically neutral, with properties similar to water.

Pumped liquid temperature range: from 0 °C to +35 °C for domestic use.

Maximum ambient temperature: +40 °C.

Maximum operating pressure: PN10.

Special executions on request: contact our sales network.

Protection class: IP44.

APPLICATIONS

Pressure booster sets particularly suited for domestic use, and small civil, agricultural, or industrial systems, where the function required is the self-priming of the pump (suction capability also if air bubbles are present).

Their main features are reliability, simple operation, and minimum maintenance requirements.

CONSTRUCTION FEATURES - COMPONENTS

HYDRAULIC SECTION

2 JET centrifugal self-priming pumps.

Galvanized sheet steel base complete with 4 rubber anti-vibration feet.

Suction and delivery manifolds in galvanized steel.

Ball valves with unions on the suction and delivery ports of each pump.

Check valves on the suction port of each pump.

2 Tropicalized galvanized cast iron plugs for closing the manifolds.

Radial manometer with isolator valve.

1 8 litre membrane pressure tank (it optimises the number of pump starts).

ELECTRICAL SECTION

1 Active Driver Plus module on the delivery line of each pump (see Active Driver Plus information at the beginning of this section).

1 protection control unit.

MULTI INVERTER SYSTEM WITH ACTIVE DRIVER PLUS

The inverter provides constant control of the rotation speed of the electric pump, ensuring constant pressure despite flow rate variations.

The other electric pumps, also with variable speed, are activated in cascade after the first one has reached maximum speed. Through modulation, they compensate the pressure fluctuations of the system.

For every operating cycle, it is possible to switch the restart to a different pump, therefore ensuring even use of all electric pumps.

It is possible to set operation times for each individual pump, switching to another pump after such set times.

The "SP" pressure can be adjusted by the user using two "+" and "-" keys on the A.D. (as a rule, all the pumps are set to the same pressure value).

MATERIALS

N.	PARTS*	MATERIALS
1	PUMP BODY	CAST IRON 200 UNI ISO 185
3	SUPPORT	DIE-CAST ALUMINIUM
4	IMPELLER	TECHNOPOLYMER A
7	SHAFT WITH ROTOR	AISI 416 X12 2 UNI 6900/71 STAINLESS STEEL
16	MECHANICAL SEAL	CARBON / CERAMIC
28	OR RING	NBR RUBBER
160	VENTURI DIFFUSER NOZZLE ASSEMBLY	TECHNOPOLYMER A

* In contact with the liquid

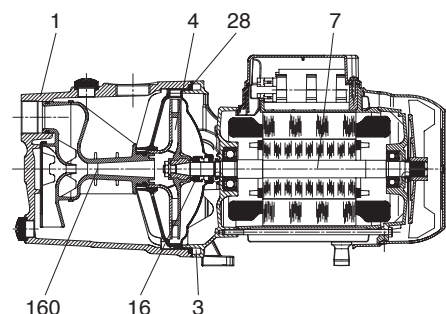

2 JET AD - DOMESTIC PRESSURE BOOSTER SETS

Pumped liquid temperature range: from 0 °C to +35 °C - Maximum ambient temperature: +40 °C - Max flow rate: 14.4 m³/h

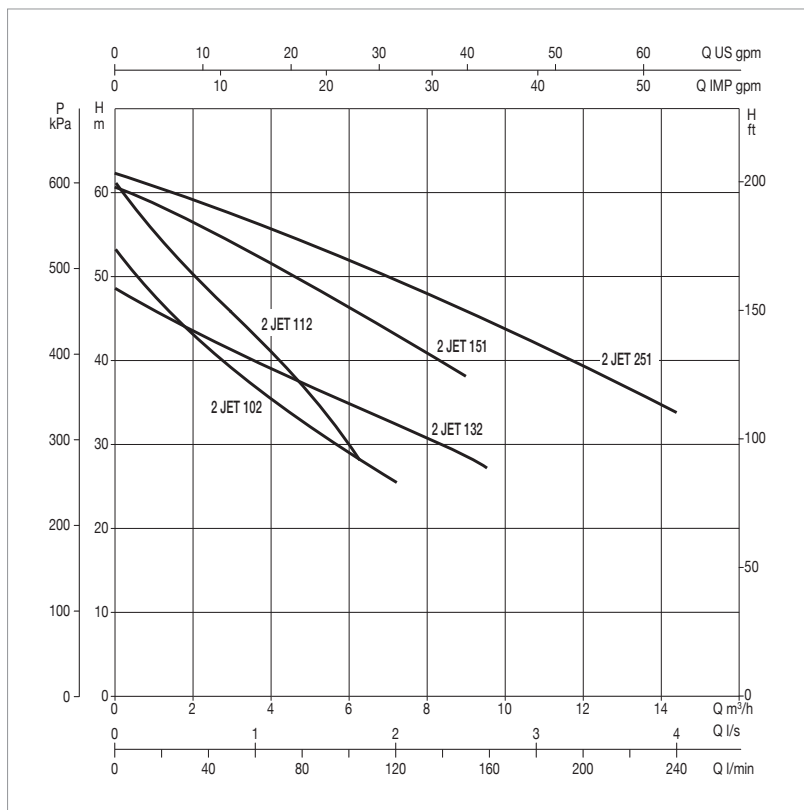
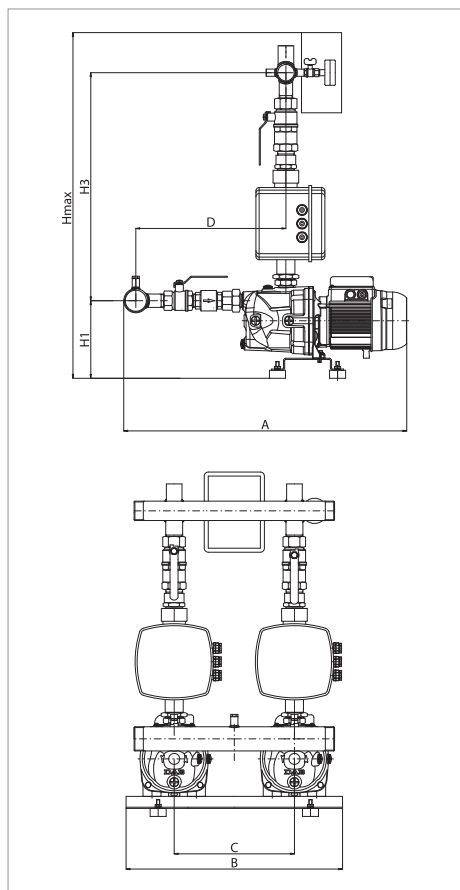

The performance curves are based on kinematic viscosity values = 1 mm²/s and density equal to 1000 kg/m³. Curve tolerance according to ISO 9906. **Overall performance taking into account TWO pumps working at the same time.** The performance results of sets with smaller pumps (e.g. 2JET 92) are obtained through simple calibration of the AD module.

MODEL	POWER INPUT 50 Hz	P2 NOMINAL		ACTIVE DRIVER PLUS MODEL	In (set) A	FLOW m ³ /h	MAX PRESSURE BAR	STANDARD PRESSURE BAR
		kW	HP					
2 JET AD 102	1x220-240 V~	2x0,75	2x1	MT 1,0	2x5,7	6.6-3.0	5	4
2 JET AD 112	1x220-240 V~	2x1	2x1,36	MT 1,0	2x7,4	6.6-3.0	5,8	4,5
2 JET AD 132	1x220-240 V~	2x1	2x1,36	MT 1,0	2x8,1	9.6-3.0	4,6	3,5
2 JET AD 151	1x220-240 V~	2x1,1	2x1,5	MT 2,2	2x9	9.4-5.0	6	5
2 JET AD 251	3x400 V~ (3+N) *	2x1,85	2x2,5	MT 2,2	2x12	14.4-7.2	6	5

* Single phase power input also available on request (1x220-240 V~).

MODEL	A	B	C	D	H max	H1	H3	DNA	DNM	PACKING DIMENSIONS			VOLUME m ³	WEIGHT kg
										L/A	L/B	H		
2 JET AD 102	706	540	300	374	862	193	569	2"	1" 1/2	850	610	1000	0,52	56
2 JET AD 112	706	540	300	374	862	193	569	2"	1" 1/2	850	610	1000	0,52	56
2 JET AD 132	706	540	300	374	862	193	569	2"	1" 1/2	850	610	1000	0,52	56
2 JET AD 151	706	540	300	374	862	193	569	2"	1" 1/2	850	610	1000	0,52	96
2 JET AD 251	706	540	300	374	862	193	569	2"	1" 1/2	850	610	1000	0,52	105

The sets are supplied in a sturdy cardboard packaging on wooden pallet and installation / maintenance manual.

2 JETINOX AD

DOMESTIC CONSTANT PRESSURE BOOSTER SETS WITH ACTIVE DRIVER PLUS

ACTIVE DRIVER PLUS
PAGE 166



TECHNICAL DATA

Operating range: from 0,4 to 14,4 m³/h

Pumped liquid: clean, free of solids and abrasives, non viscous, non aggressive, non crystallised and chemically neutral, with properties similar to water.

Pumped liquid temperature range: from 0 °C to +35 °C for domestic use.

Maximum ambient temperature: +40°C

Maximum operating pressure: PN10

Special executions on request: contact our sales network.

Protection class: IP44

APPLICATIONS

Pressure booster sets particularly suited for domestic use, and small civil, agricultural, or industrial systems, where the function required is the self-priming of the pump (suction capability also if air bubbles are present).

Their main features are reliability, simple operation, and minimum maintenance requirements.

CONSTRUCTION FEATURES - COMPONENTS

HYDRAULIC SECTION

2 JET centrifugal self-priming pumps.

Galvanized sheet steel base complete with 4 rubber anti-vibration feet.

AISI 304 STAINLESS STEEL suction and delivery manifolds in .

Ball valves with unions on the suction and delivery ports of each pump.

Check valves on the suction port of each pump.

2 AISI 304 STAINLESS STEEL plug for closing the manifolds.

Radial manometer with isolator valve.

1 8 litre membrane pressure tank (it optimises the number of pump starts).

ELECTRICAL SECTION

1 Active Driver Plus module on the delivery line of each pump (see Active Driver Plus information at the beginning of this section).

1 protection control unit.

MULTI INVERTER SYSTEM WITH ACTIVE DRIVER PLUS

The inverter provides constant control of the rotation speed of the electric pump, ensuring constant pressure despite flow rate variations.

The other electric pumps, also with variable speed, are activated in cascade after the first one has reached maximum speed. Through modulation, they compensate the pressure fluctuations of the system.

For every operating cycle, it is possible to switch the restart to a different pump, therefore ensuring even use of all electric pumps.

It is possible to set operation times for each individual pump, switching to another pump after such set times.

The "SP" pressure can be adjusted by the user using two "+" and "-" keys on the A.D. (as a rule, all the pumps are set to the same pressure value).

MATERIALS

N.	PARTS*	MATERIALS
1	PUMP BODY	AISI 304 STAINLESS STEEL X5 CRNi 1810 - UNI 6900/71
4	IMPELLER	TECHNOPOLYMER A
7	SHAFT WITH ROTOR	AISI 416 X12 2 UNI 6900/71 STAINLESS STEEL
16	MECHANICAL SEAL	CARBON / CERAMIC
28	OR RING	NBR RUBBER
36	SEAL COVER	AISI 304 STAINLESS STEEL X5 CRNi 1810 - UNI 6900/71
160	VENTURI DIFFUSER NOZZLE ASSEMBLY	TECHNOPOLYMER A

* In contact with the liquid

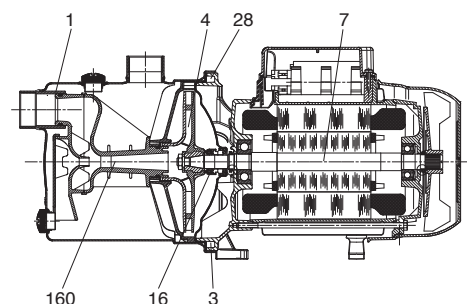

2 JET AD - DOMESTIC PRESSURE BOOSTER SETS

Pumped liquid temperature range: from 0 °C to +35 °C - Maximum ambient temperature: +40 °C - Max flow rate: 14.4 m³/h

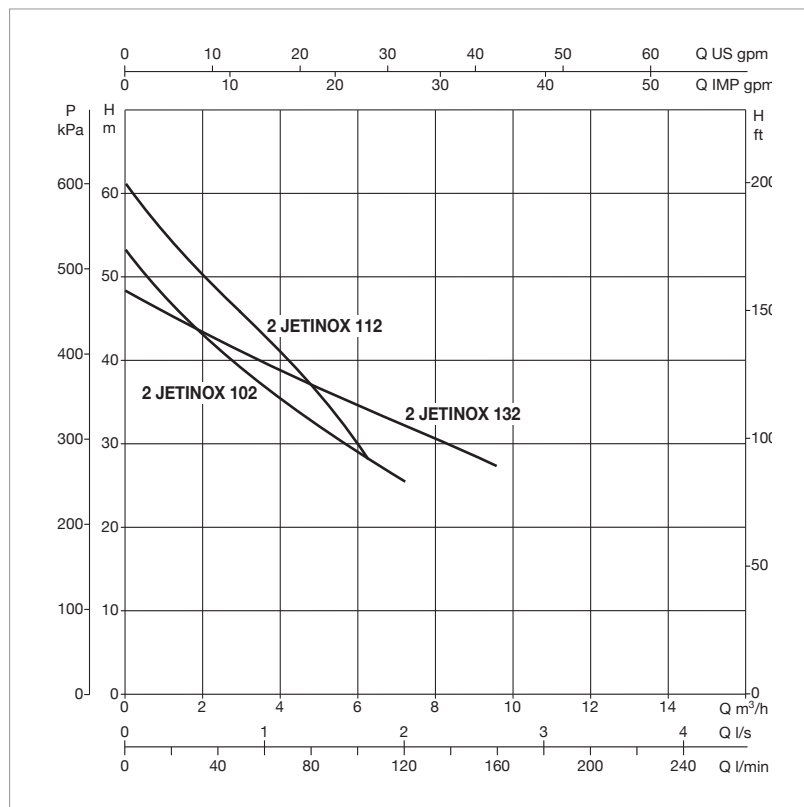
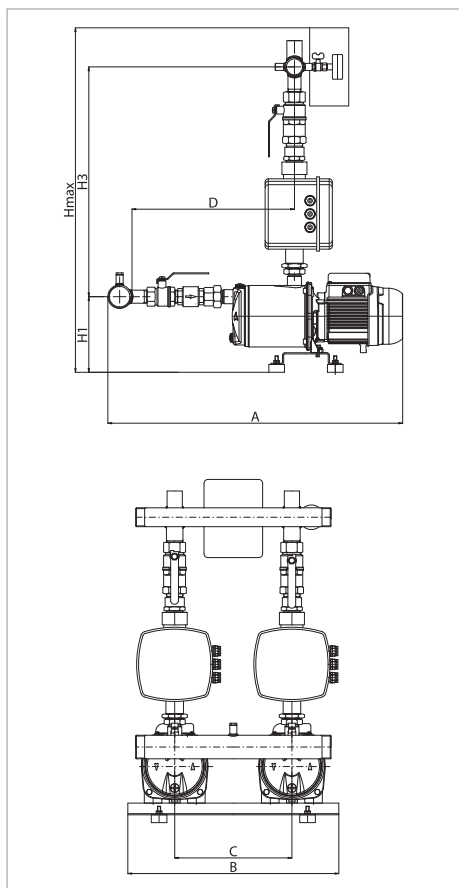

The performance curves are based on kinematic viscosity values = 1 mm²/s and density equal to 1000 kg/m³.
Curve tolerance according to ISO 9906. **Overall performance taking into account TWO pumps working at the same time.**
The performance results of sets with smaller pumps (e.g. 2JETINOX 92) are obtained through simple calibration of the AD module.

MODEL	POWER INPUT 50 Hz	P2 NOMINAL		ACTIVE DRIVER PLUS MODEL	In (set) A	FLOW m ³ /h	MAX PRESSURE BAR	STANDARD PRESSURE BAR
		kW	HP					
2 JETINOX AD 102.	1x220-240 V~	2x0,75	2x1	MT 1,0	2x5,7	6.6-3.0	5	4
2 JETINOX AD 112.	1x220-240 V~	2x1	2x1,36	MT 1,0	2x7,4	6.6-3.0	5,8	4,5
2 JETINOX AD 132.	1x220-240 V~	2x1	2x1,36	MT 1,0	2x8,1	9.6-3.0	4,6	3,5

MODEL	A	B	C	D	H max	H1	H3	DNA	DNM	PACKING DIMENSIONS			VOLUME m ³	WEIGHT kg
										L/A	L/B	H		
2 JETINOX AD 102.	755	540	300	416	882	193	588	2"	1" 1/2	850	610	1000	0,52	56
2 JETINOX AD 112.	755	540	300	416	882	193	588	2"	1" 1/2	850	610	1000	0,52	56
2 JETINOX AD 132.	755	540	300	416	882	193	588	2"	1" 1/2	850	610	1000	0,52	56

The sets are supplied in a sturdy cardboard packaging on wooden pallet and installation / maintenance manual.

ACTIVE DRIVER PLUS
PAGE 166



TECHNICAL DATA

Operating range: from 0,4 to 14,5 m³/h.

Pumped liquid: clean, free of solids and abrasives, non viscous, non aggressive, non crystallised and chemically neutral, with properties similar to water.

Pumped liquid temperature range: from 0 °C to +35 °C for domestic use.

Maximum ambient temperature: +40°C.

Maximum operating pressure: PN10.

Special executions on request: contact our sales network.

Protection class: IP44.

APPLICATIONS

Pressure booster sets particularly suited for domestic use, and small civil, agricultural, or industrial systems. Their main features are reliability, simple operation, and minimum maintenance requirements.

CONSTRUCTION FEATURES - COMPONENTS

HYDRAULIC SECTION

2 EURO multistage centrifugal electric pumps.

Galvanized sheet steel base complete with 4 rubber anti-vibration feet.

Suction and delivery manifolds in galvanized steel.

Ball valves with unions on the suction and delivery ports of each pump.

Check valves on the suction port of each pump.

2 Tropicalized galvanized cast iron plugs for closing the manifolds.

Radial manometer with isolator valve.

1 8 litre membrane pressure tank (it optimises the number of pump starts).

ELECTRICAL SECTION

1 Active Driver Plus module on the delivery line of each pump (see Active Driver Plus information at the beginning of this section).

1 protection control unit.

MULTI INVERTER SYSTEM WITH ACTIVE DRIVER PLUS

The inverter provides constant control of the rotation speed of the electric pump, ensuring constant pressure despite flow rate variations.

The other electric pumps, also with variable speed, are activated in cascade after the first one has reached maximum speed. Through modulation, they compensate the pressure fluctuations of the system.

For every operating cycle, it is possible to switch the restart to a different pump, therefore ensuring even use of all electric pumps.

It is possible to set operation times for each individual pump, switching to another pump after such set times.

The "SP" pressure can be adjusted by the user using two "+" and "-" keys on the A.D. (as a rule, all the pumps are set to the same pressure value).

MATERIALS

N.	PARTS*	MATERIALS
1	PUMP BODY	CAST IRON 200 UNI ISO 185
4	IMPELLER	TECHNOPOLYMER
6	DIFFUSER	TECHNOPOLYMER
7	SHAFT WITH ROTOR	AISI 304 STAINLESS STEEL X5CrNi 1810 UNI 6900/71
16	MECHANICAL SEAL	CARBON / CERAMIC
28	OR RING	NBR
36	SEAL COVER	AISI 304 STAINLESS STEEL X5CrNi 1810 UNI 6900/71
98	DIFFUSER BODY	TECHNOPOLYMER
304	REAR DISC	TECHNOPOLYMER

* In contact with the liquid

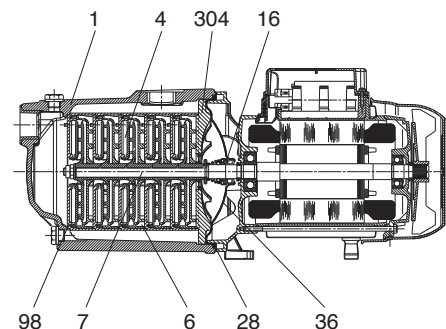

2 EURO AD - DOMESTIC PRESSURE BOOSTER SETS

Pumped liquid temperature range: from 0 °C to +35 °C for domestic use - from 0 °C to +40 °C for other uses.

Maximum ambient temperature: +40 °C - Max flow rate: 14.5 m³/h

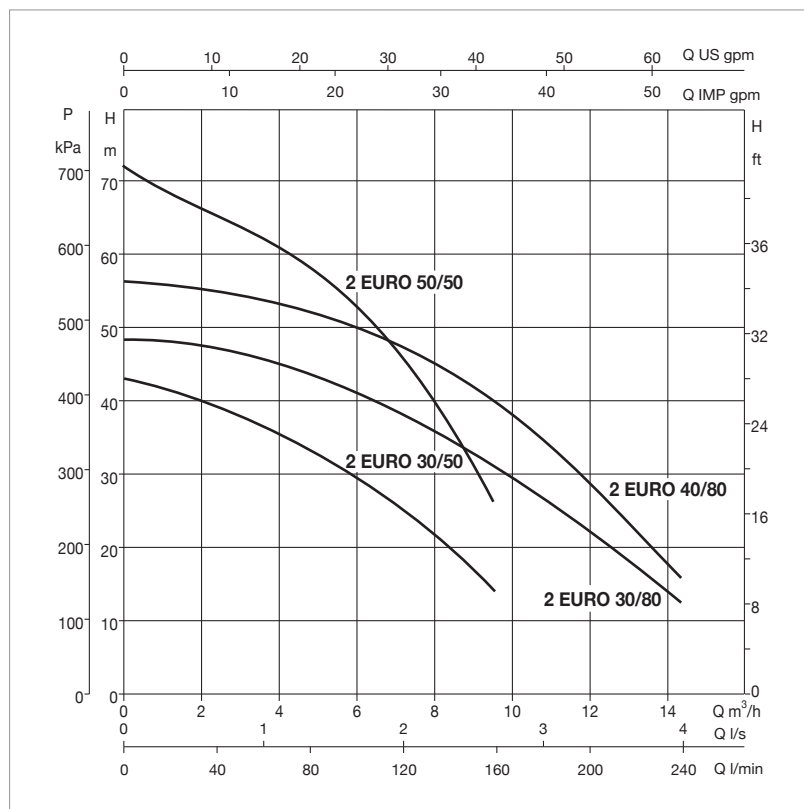
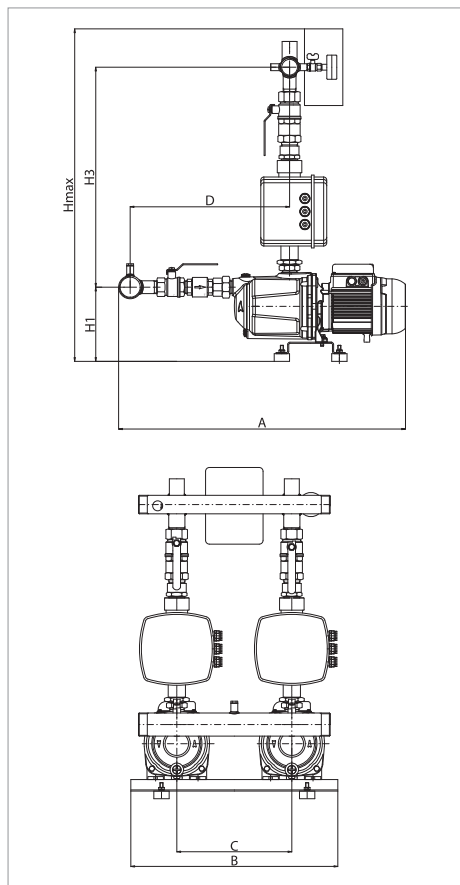

The performance curves are based on kinematic viscosity values = 1 mm²/s and density equal to 1000 kg/m³.
Curve tolerance according to ISO 9906. **Overall performance taking into account TWO pumps working at the same time.**
The performance results of sets with smaller pumps (e.g. 2 EURO 40/50) are obtained through simple calibration of the AD module.

MODEL	POWER INPUT 50 Hz	P2 NOMINAL		ACTIVE DRIVER PLUS MODEL	In (set) A	FLOW m ³ /h	MAX PRESSURE BAR	STANDARD PRESSURE BAR
		KW	HP					
2 EURO AD 30/50	1x220-240 V~	2x0,55	2x0,75	MT 1,0	2x4,8	8.0-4.4	3,8	3
2 EURO AD 50/50	1x220-240 V~	2x1	2x1,36	MT 1,0	2x7,6	7.6-5.2	6,5	5
2 EURO AD 30/80	1x220-240 V~	2x0,8	2x1,1	MT 1,0	2x6,5	11.0-7.0	4,3	3,5
2 EURO AD 40/80	1x220-240 V~	2x1	2x1,36	MT 1,0	2x7,6	10.0-6.0	5,5	4,5

MODEL	A	B	C	D	H max	H1	H3	DNA	DNM	PACKING DIMENSIONS			VOLUME m ³	WEIGHT kg
										L/A	L/B	H		
2 EURO AD 30/50	748	540	300	416	867	194	574	2"	1" 1/2	850	610	1000	0,52	57
2 EURO AD 50/50	748	540	300	416	867	194	574	2"	1" 1/2	850	610	1000	0,52	57
2 EURO AD 30/80	748	540	300	416	867	194	574	2"	1" 1/2	850	610	1000	0,52	57
2 EURO AD 40/80	748	540	300	416	867	194	574	2"	1" 1/2	850	610	1000	0,52	57

The sets are supplied in a sturdy cardboard packaging on wooden pallet and installation / maintenance manual.

2 EUROINOX AD

DOMESTIC CONSTANT PRESSURE BOOSTER SETS WITH ACTIVE DRIVER PLUS

ACTIVE DRIVER PLUS
PAGE 166



TECHNICAL DATA

Operating range: from 0,4 to 14,5 m³/h

Pumped liquid: clean, free of solids and abrasives, non viscous, non aggressive, non crystallised and chemically neutral, with properties similar to water.

Pumped liquid temperature range: from 0 °C to +35 °C for domestic use.

Maximum ambient temperature: +40°C

Maximum operating pressure: PN10

Special executions on request: contact our sales network.

Protection class: IP44

APPLICATIONS

Pressure booster sets particularly suited for domestic use, and small civil, agricultural, or industrial systems, where the function required is the self-priming of the pump (suction capability also if air bubbles are present).

Their main features are reliability, simple operation, and minimum maintenance requirements.

CONSTRUCTION FEATURES - COMPONENTS

HYDRAULIC SECTION

2 EUROINOX multistage centrifugal electric pumps.

Galvanized sheet steel base complete with 4 rubber anti-vibration feet.

AISI 304 STAINLESS STEEL suction and delivery manifolds in .

Ball valves with unions on the suction and delivery ports of each pump.

Check valves on the suction port of each pump.

2 AISI 304 STAINLESS STEEL plug for closing the manifolds.

Radial manometer with isolator valve.

1 8 litre membrane pressure tank (it optimises the number of pump starts).

ELECTRICAL SECTION

1 Active Driver Plus module on the delivery line of each pump (see Active Driver Plus information at the beginning of this section). 1 protection control unit.

MULTI INVERTER SYSTEM WITH ACTIVE DRIVER PLUS

The inverter provides constant control of the rotation speed of the electric pump, ensuring constant pressure despite flow rate variations.

The other electric pumps, also with variable speed, are activated in cascade after the first one has reached maximum speed. Through modulation, they compensate the pressure fluctuations of the system. For every operating cycle, it is possible to switch the restart to a different pump, therefore ensuring even use of all electric pumps. It is possible to set operation times for each individual pump, switching to another pump after such set times. The "SP" pressure can be adjusted by the user using two "+" and "-" keys on the A.D. (as a rule, all the pumps are set to the same pressure value).

MATERIALS

N.	PARTS*	MATERIALS
1	PUMP BODY	AISI 304 STAINLESS STEEL X5CrNi 1810 UNI 6900/71
4	IMPELLER	TECHNOPOLYMER
6	DIFFUSER	TECHNOPOLYMER
7	SHAFT WITH ROTOR	AISI 304 STAINLESS STEEL X5CrNi 1810 UNI 6900/71
16	MECHANICAL SEAL	CARBON / CERAMIC
28	OR RING	NBR
36	SEAL COVER	AISI 304 STAINLESS STEEL X5CrNi 1810 UNI 6900/71
98	DIFFUSER BODY	TECHNOPOLYMER
304	REAR DISC	TECHNOPOLYMER
305	FRONT DISC	TECHNOPOLYMER

* In contact with the liquid

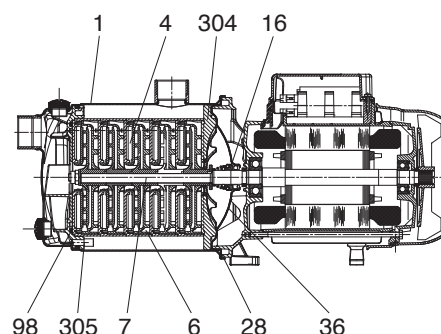

2 EUROINOX AD - DOMESTIC PRESSURE BOOSTER SETS

Pumped liquid temperature range: from 0 °C to +35 °C for domestic use - from 0 °C to +40 °C for other uses.

Maximum ambient temperature: +40 °C - Max flow rate: 14.5 m³/h

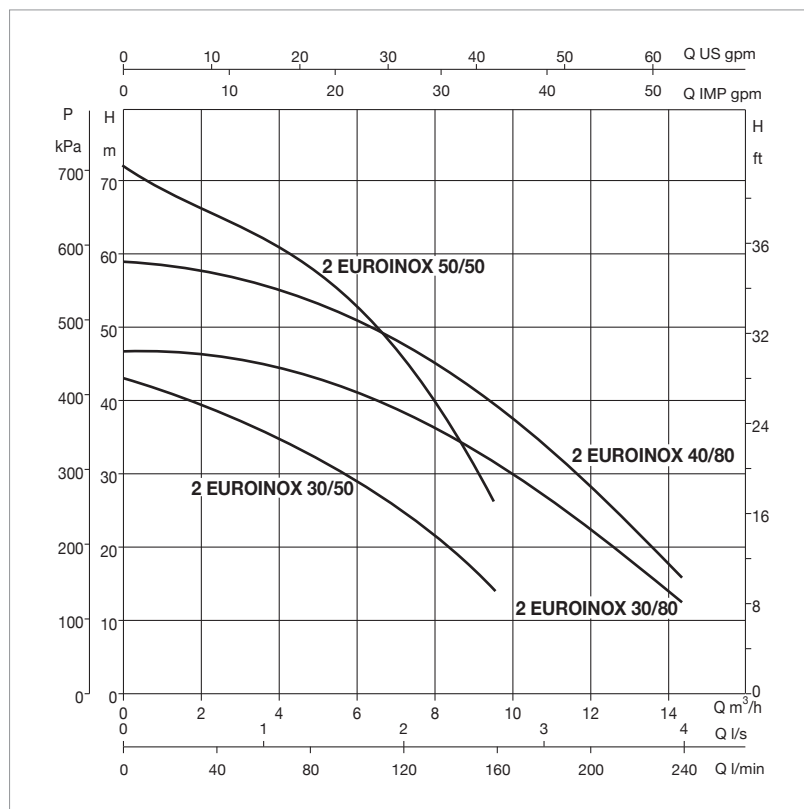
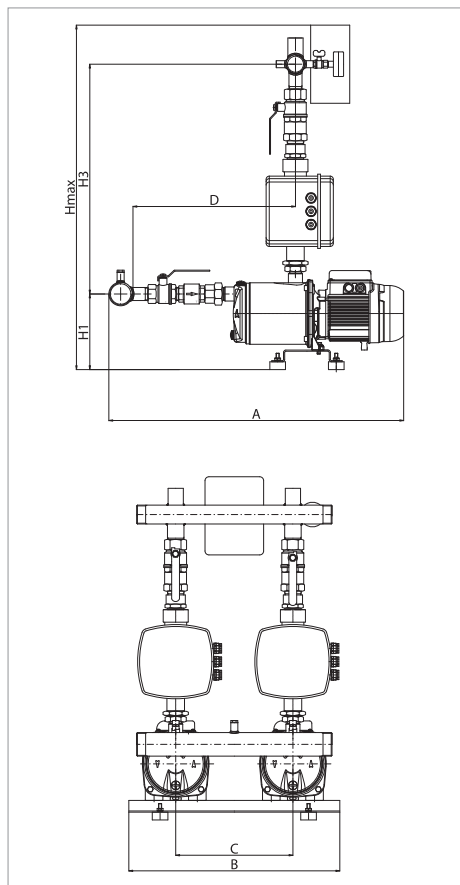

The performance curves are based on kinematic viscosity values = 1 mm²/s and density equal to 1000 kg/m³.
Curve tolerance according to ISO 9906. **Overall performance taking into account TWO pumps working at the same time.**
The performance results of sets with smaller pumps (e.g. 2 EUROINOX 40/50) are obtained through simple calibration of the AD module.

MODEL	POWER INPUT 50 Hz	P2 NOMINAL		ACTIVE DRIVER PLUS MODEL	In (set) A	FLOW m ³ /h	MAX PRESSURE BAR	STANDARD PRESSURE BAR
		KW	HP					
2 EUROINOX AD 30/50	1x220-240 V~	2x0,55	2x0,75	MT 1,0	2x4,8	8.0-4.4	3,8	3
2 EUROINOX AD 50/50	1x220-240 V~	2x1	2x1,36	MT 1,0	2x7,6	7.6-5.2	6,5	5
2 EUROINOX AD 30/80	1x220-240 V~	2x0,8	2x1,1	MT 1,0	2x6,5	11.0-7.0	4,3	3,5
2 EUROINOX AD 40/80	1x220-240 V~	2x1	2x1,36	MT 1,0	2x7,6	10.0-6.0	5,5	4,5

MODEL	A	B	C	D	H max	H1	H3	DNA	DNM	PACKING DIMENSIONS			VOLUME m ³	WEIGHT kg
										L/A	L/B	H		
2 EUROINOX AD 30/50	755	540	300	416	882	193	588	2"	1" 1/2	850	610	1000	0,52	57
2 EUROINOX AD 50/50	755	540	300	416	882	193	588	2"	1" 1/2	850	610	1000	0,52	57
2 EUROINOX AD 30/80	755	540	300	416	882	193	588	2"	1" 1/2	850	610	1000	0,52	57
2 EUROINOX AD 40/80	755	540	300	416	882	193	588	2"	1" 1/2	850	610	1000	0,52	57

The sets are supplied in a sturdy cardboard packaging on wooden pallet and installation / maintenance manual.

1-2-3 KVC AD

DOMESTIC CONSTANT PRESSURE BOOSTER SETS WITH ACTIVE DRIVER PLUS

ACTIVE DRIVER PLUS
PAGE 166



TECHNICAL DATA

Operating range: from 0,5 to 36 m³/h

Pumped liquid: clean, free of solids and abrasives, non viscous, non aggressive, non crystallised and chemically neutral, with properties similar to water.

Pumped liquid temperature range: from 0°C to +40°C.

Maximum ambient temperature: +40°C

Maximum operating pressure: PN16

Special executions on request: contact our sales network.

Protection class: IP44

APPLICATIONS

Pressure booster sets particularly suited for domestic use, small civil, agricultural, or industrial systems, irrigation systems, and washing systems. Their main features are reliability, simple operation, and minimum maintenance requirements.

CONSTRUCTION FEATURES - COMPONENTS

HYDRAULIC SECTION

KVC multistage centrifugal electric pumps.

Galvanized sheet steel base complete with 4 rubber anti-vibration feet.

AISI 304 STAINLESS STEEL Suction and delivery manifolds.

Ball valves with unions on the suction and delivery ports of each pump.

Check valves on the suction port of each pump.

2 AISI 304 STAINLESS STEEL plug for closing the manifolds.

Radial manometer with isolator valve.

1 8 litre membrane pressure tank (it optimises the number of pump starts).

ELECTRICAL SECTION

1 Active Driver Plus module on the delivery line of each pump (see Active Driver Plus information at the beginning of this section).

1 protection control unit.

MULTI INVERTER SYSTEM WITH ACTIVE DRIVER PLUS

The inverter provides constant control of the rotation speed of the electric pump, ensuring constant pressure despite flow rate variations.

The other electric pumps, also with variable speed, are activated in cascade after the first one has reached maximum speed. Through modulation, they compensate the pressure fluctuations of the system.

For every operating cycle, it is possible to switch the restart to a different pump, therefore ensuring even use of all electric pumps.

It is possible to set operation times for each individual pump, switching to another pump after such set times.

The "SP" pressure can be adjusted by the user using two "+" and "-" keys on the A.D. (as a rule, all the pumps are set to the same pressure value).

MATERIALS

N.	PARTS*	MATERIALS
1	PUMP BODY	TECHNOPOLYMER A
4	IMPELLER	TECHNOPOLYMER B
6	DIFFUSER	TECHNOPOLYMER B
7	SHAFT WITH ROTOR	AISI 303 STAINLESS STEEL X10 CrNi S 1089 UNI 6900/71
16	MECHANICAL SEAL	SILICON CARBIDE/SILICON
28	OR RING	EPDM RUBBER
36	SEAL HOLDING DISC	AISI 304 STAINLESS STEEL X5 CrNi 1810 UNI 6900/71
57a	INTERMEDIATE STAGE	TECHNOPOLYMER B
69	LINER	AISI 304 STAINLESS STEEL X5 CrNi 1810 UNI 6900/71
98	DIFFUSER BODY	TECHNOPOLYMER B
271	CENTERING BUSHING	BRONZE B14
304	CONVEYOR	TECHNOPOLYMER B
8	DNM (standard for KVCX only)	

* In contact with the liquid.

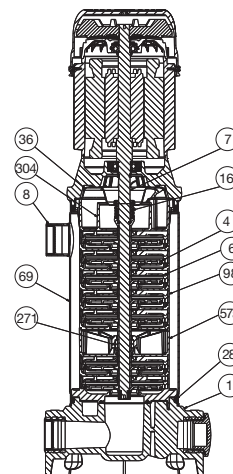

1 KVC AD - DOMESTIC PRESSURE BOOSTER SETS

Pumped liquid temperature range: from 0 °C to +35 °C for domestic use - from 0 °C to +40 °C for other uses.

Maximum ambient temperature: +40 °C - Max flow rate: 12 m³/h

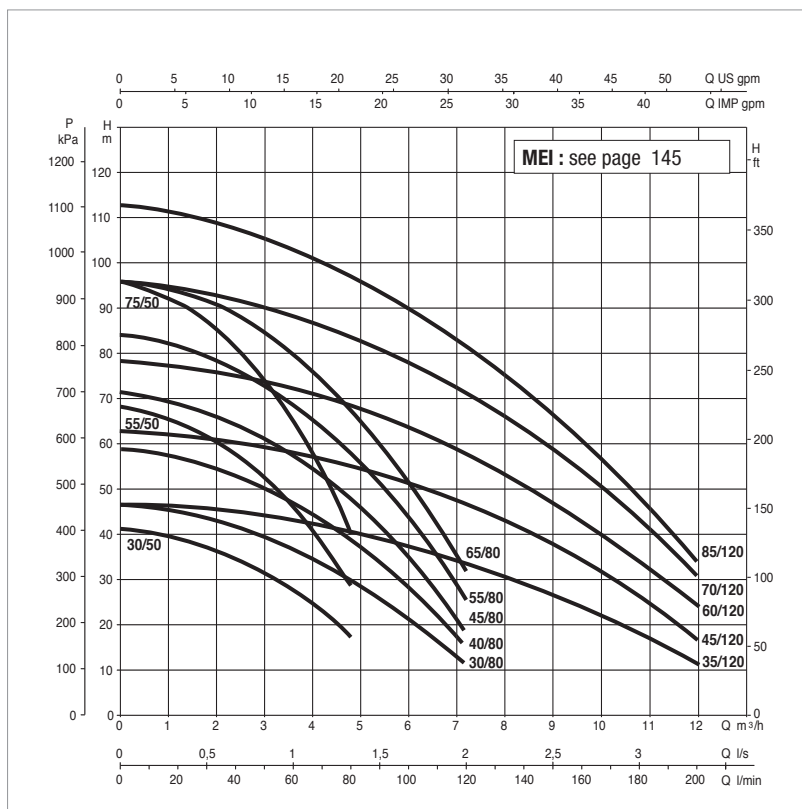
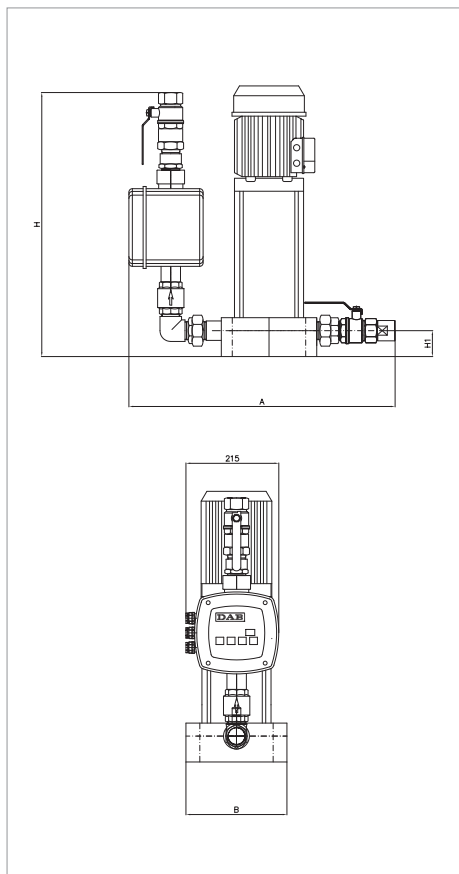

The performance curves are based on kinematic viscosity values = 1 mm²/s and density equal to 1000 kg/m³.

Curve tolerance according to ISO 9906.

The performance results of sets with smaller pumps (e.g. KVC AD 30/50) are obtained through simple calibration of the AD module.

MODEL	POWER INPUT 50 Hz	P2 NOMINAL		In (set) A	ACTIVE DRIVER PLUS MODEL	FLOW m ³ /h	MAX PRESSURE BAR	STANDARD PRESSURE BAR
		KW	HP					
1 KVC AD 30/50	1x220-240 V~	0,55	0,75	4,1	MT 1,0	4,5-1	4	3,5
1 KVC AD 55/50	1x220-240 V~	1	1,36	7,6	MT 1,0	4,5-1	6,5	5,5
1 KVC AD 75/50	1x220-240 V~	1,5	2	10,7	MT 2,2	4,5-1	9,2	8
1 KVC AD 30/80	1x220-240 V~	0,8	1,1	6,5	MT 1,0	7-2	4,5	3,5
1 KVC AD 40/80	1x220-240 V~	1,0	1	7,7	MT 1,0	7-2	5,8	5
1 KVC AD 45/80	1x220-240 V~	1,1	1,5	9,3	MT 2,2	7-2	6,6	5,5
1 KVC AD 55/80	1x220-240 V~	1,5	2	10,5	MT 2,2	7-2	8,4	7,5
1 KVC AD 65/80	1x220-240 V~	2,2	3	12	MT 2,2	7-2	9,2	8
1 KVC AD 35/120	1x220-240 V~	1,1	1,5	10,4	MT 2,2	11-2	4,4	3,5
1 KVC AD 45/120	1x220-240 V~	1,85	2,50	13,6	MT 2,2	11-2	6,0	5,0
1 KVC AD 60/120	3x400 V~	2,2	3	5,4	T/T 3,0	11-2	7,5	6
1 KVC AD 70/120	3x400 V~	3	4	6,8	T/T 3,0	11-2	9,5	7
1 KVC AD 85/120	3x400 V~	3	34	7,8	T/T 5,5	11-2	11	8

MODEL	A	B	H1	H3	DNA	DNM	PACKING DIMENSIONS			VOLUME m ³	WEIGHT kg
							L/A	L/B	H		
1 KVC AD 30/50	530	250	620	60	1" 1/4	1" 1/4	850	610	1000	0,52	32
1 KVC AD 55/50	530	250	620	60	1" 1/4	1" 1/4	850	610	1000	0,52	35
1 KVC AD 75/50	530	250	620	60	1" 1/4	1" 1/4	850	610	1000	0,52	39
1 KVC AD 30/80	530	250	620	60	1" 1/4	1" 1/4	850	610	1000	0,52	34
1 KVC AD 40/80	530	250	620	60	1" 1/4	1" 1/4	850	610	1000	0,52	36
1 KVC AD 45/80	530	250	620	60	1" 1/4	1" 1/4	850	610	1000	0,52	38
1 KVC AD 55/80	530	250	620	60	1" 1/4	1" 1/4	850	610	1000	0,52	39
1 KVC AD 65/80	530	250	620	60	1" 1/4	1" 1/4	850	610	1000	0,52	40
1 KVC AD 35/120	530	250	620	60	1" 1/4	1" 1/4	850	610	1000	0,52	34
1 KVC AD 45/120	530	250	620	60	1" 1/4	1" 1/4	850	610	1000	0,52	37
1 KVC AD 60/120	530	250	620	60	1" 1/4	1" 1/4	850	610	1000	0,52	39
1 KVC AD 70/120	530	250	620	60	1" 1/4	1" 1/4	850	610	1000	0,52	40
1 KVC AD 85/120	530	234	620	60	1" 1/4	1" 1/4	850	610	1000	0,52	41

The sets are supplied in a sturdy cardboard packaging on wooden pallet and installation / maintenance manual.

2 KVC AD - DOMESTIC PRESSURE BOOSTER SETS

Pumped liquid temperature range: from 0 °C to +35 °C for domestic use - from 0 °C to +40 °C for other uses.

Maximum ambient temperature: +40 °C - Max flow rate: 24 m³/h

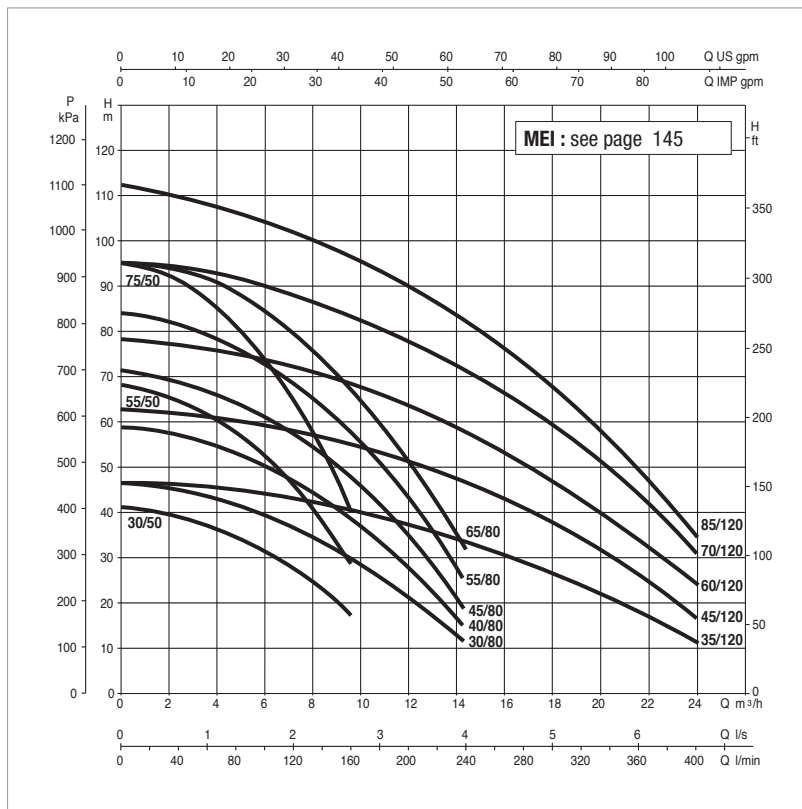
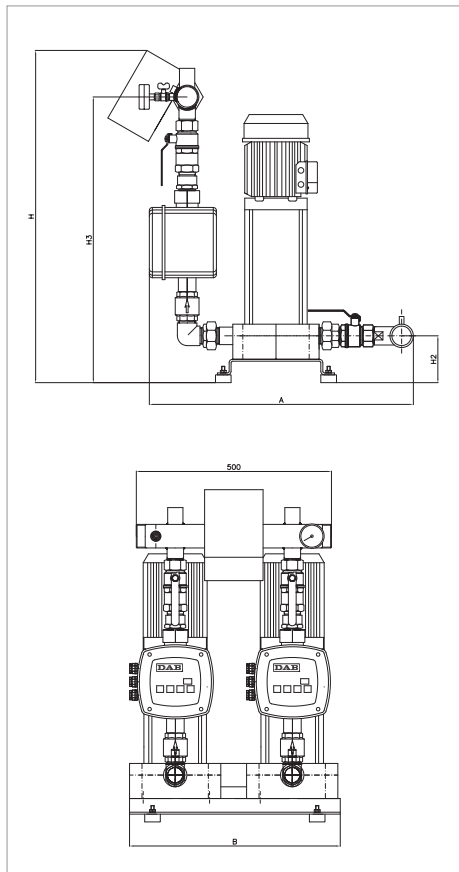

The performance curves are based on kinematic viscosity values = 1 mm²/s and density equal to 1000 kg/m³. Curve tolerance according to ISO 9906. **Overall performance taking into account TWO pumps working at the same time.** The performance results of sets with smaller pumps (e.g. 2 KVC 20/50) are obtained through simple calibration of the AD module.

MODEL	POWER INPUT 50 Hz	P2 NOMINAL		In (set) A	ACTIVE DRIVER PLUS MODEL	FLOW m³/h	MAX PRESSURE BAR	STANDARD PRESSURE BAR
		KW	HP					
2 KVC AD 30/50	1x220-240 V~	2x0,55	2x0,75	2x4,1	M/T 1,0	9-14	3,5	3,5
2 KVC AD 55/50	1x220-240 V~	2x1	2x1,36	2x7,6	M/T 1,0	9-14	6,5	5,5
2 KVC AD 75/50	3x400 V~ + N *	2x1,5	2x2	2x10,7	M/T 2,2	9-14	9,5	8
2 KVC AD 30/80	1x220-240 V~	2x0,8	2x1,1	2x6,5	M/T 1,0	14-2	4,5	3,5
2 KVC AD 40/80	1x220-240 V~	1,00	1,4	7,7	M/T 1,0	14 - 2	5,8	5
2 KVC AD 45/80	1x220-240 V~	2x1,1	2x1,5	2x9,3	M/T 2,2	14-2	6,6	5,5
2 KVC AD 55/80	1x220-240 V~	1,50	2,0	10,5	M/T2,2	14 - 2	8,4	7,5
2 KVC AD 65/80	3x400 V~ + N *	2x2,2	2x3	2x12	M/T 2,2	14-2	9,5	8
2 KVC AD 35/120	1x220-240 V~	2x1,1	2x1,5	2x10,4	M/T 2,2	22-2	4,4	3,5
2 KVC AD 45/120	1x220-240 V~	2x1,85	2x2,50	2x13,6	M/T 2,2	22-2	6,0	5,0
2 KVC AD 60/120	3x400 V~	2x2,2	2x3	2x5,4	T/T 3,0	22-2	7,5	6
2 KVC AD 70/120	3x400 V~	2x3,0	2x4	2x6,80	T/T 3,0	22-2	9,5	7
2 KVC AD 85/120	3x400 V~	2x3,0	2x4	2x7,80	T/T 5,5	22-2	11	8

* Single phase power input also available on request (1x220-240 V~).

MODEL	A	B	H	H2	H3	DNA	DNM	PACKING DIMENSIONS			VOLUME m³	WEIGHT kg
								L/A	L/B	H		
2 KVC AD 30/50	660	550	830	100	710	2"	2"	1000	610	1000	0,61	76
2 KVC AD 55/50	660	550	830	100	710	2"	2"	1000	610	1000	0,61	83
2 KVC AD 75/50	660	550	830	100	710	2"	2"	1000	610	1000	0,61	91
2 KVC AD 30/80	660	550	830	100	710	2"	2"	1000	610	1000	0,61	80
2 KVC AD 40/80	660	550	830	100	710	2"	2"	1000	610	1000	0,61	85
2 KVC AD 45/80	660	550	830	100	710	2"	2"	1000	610	1000	0,61	89
2 KVC AD 55/80	660	550	830	100	710	2"	2"	1000	610	1000	0,61	90
2 KVC AD 65/80	660	550	830	100	710	2"	2"	1000	610	1000	0,61	93
2 KVC AD 35/120	660	550	830	100	710	2"	2"	1000	610	1000	0,61	81
2 KVC AD 45/120	660	550	830	100	710	2"	2"	1000	610	1000	0,61	85
2 KVC AD 60/120	660	550	830	100	710	2"	2"	1000	610	1000	0,61	89
2 KVC AD 70/120	660	550	830	100	710	2"	2"	1000	610	1000	0,61	93
2 KVC AD 85/120	660	550	830	100	710	2"	2"	1000	610	1000	0,61	95

The sets are supplied in a sturdy cardboard packaging on wooden pallet and installation / maintenance manual.

3 KVC AD - DOMESTIC PRESSURE BOOSTER SETS

Pumped liquid temperature range: from 0 °C to +35 °C for domestic use - from 0 °C to +40 °C for other uses.

Maximum ambient temperature: +40 °C - Max flow rate: 36 m³/h

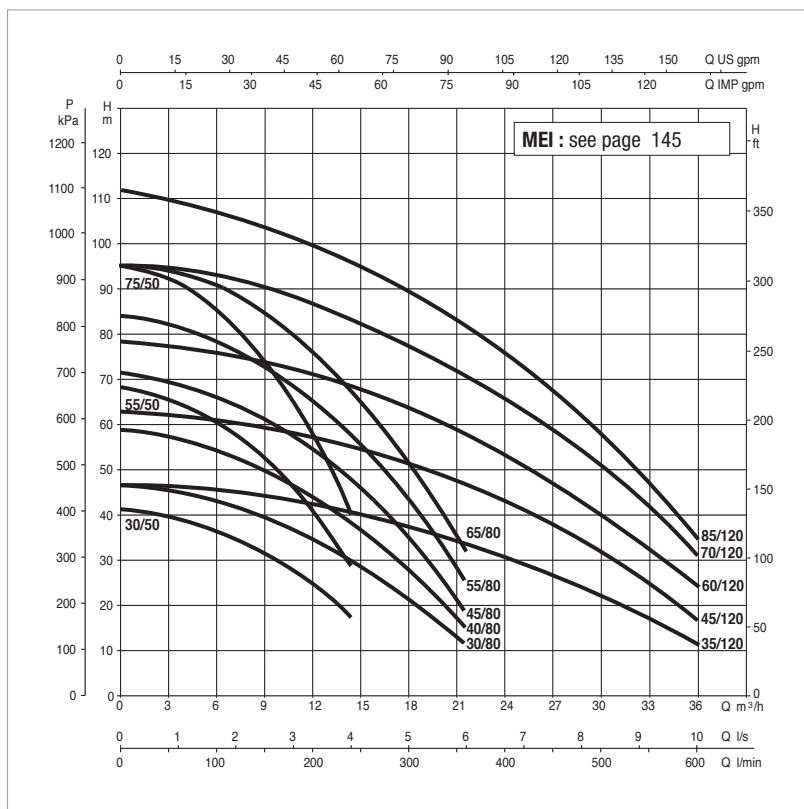
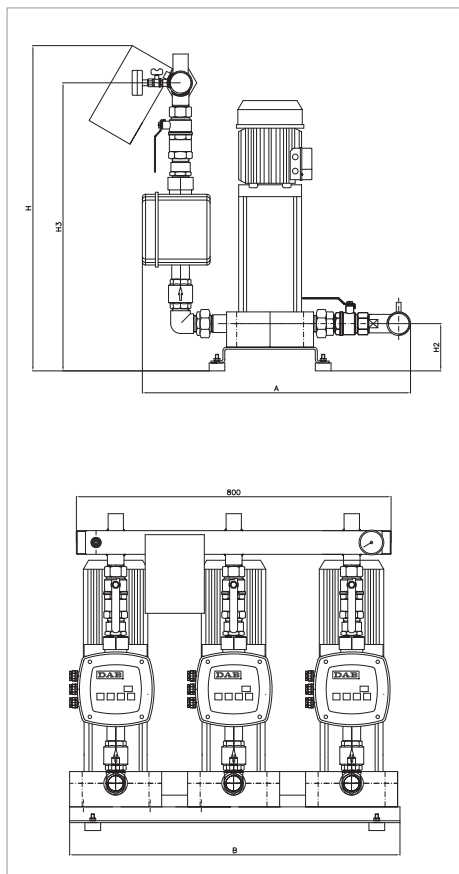

The performance curves are based on kinematic viscosity values = 1 mm²/s and density equal to 1000 kg/m³.
Curve tolerance according to ISO 9906. **Overall performance taking into account THREE pumps working at the same time.**
The performance results of sets with smaller pumps (e.g. 3 KVC 20/50) are obtained through simple calibration of the AD module.

MODEL	POWER INPUT 50 Hz	P2 NOMINAL		ACTIVE DRIVER PLUS MODEL	In (set) A	FLOW m ³ /h	MAX PRESSURE BAR	STANDARD PRESSURE BAR
		kW	HP					
3 KVC AD 30/50	1x220-240 V~	3x0,55	3x0,75	3x4,1	MT 1,0	13,5-1	4	3,5
3 KVC AD 55/50	3x400 V~ + N *	3x1	3x1,36	3x7,6	MT 1,0	13,5-1	6,5	5,5
3 KVC AD 75/50	3x400 V~ + N *	3x1,5	3x2	3x10,7	MT 2,2	13,5-1	9,5	8
3 KVC AD 30/80	3x400 V~ + N *	3x0,8	3x1,1	3x6,5	MT 1,0	21-2	4,5	3,5
3 KVC AD 40/80	3x400 V~ + N *	1,00	1,4	7,7	MT 2,2	21 - 2	5,8	5
3 KVC AD 45/80	3x400 V~ + N *	3x1,1	3x1,5	3x9,3	MT 2,2	21-2	6,6	5,5
3 KVC AD 55/80	3x400 V~ + N *	1,50	2,0	10,5	MT 2,2	21 - 2	8,4	7,5
3 KVC AD 65/80	3x400 V~ + N *	3x2,2	3x3	3x12	MT 2,2	21-2	9,5	8
3 KVC AD 35/120	3x400 V~ + N *	3x1,1	3x1,5	3x10,4	MT 2,2	33-2	4,4	3,5
3 KVC AD 45/120	3x400 V~ + N *	3x1,85	3x2,5	3x13,6	MT 2,2	33-2	6,0	5,0
3 KVC AD 60/120	3x400 V	3x2,2	3x3	3x5,4	T/T 3,0	33-2	7,5	6
3 KVC AD 70/120	3x400 V	3x3,0	3x4	3x6,80	T/T 3,0	33-2	9,5	7
3 KVC AD 85/120	3x400 V	3x3,0	3x4	3x7,80	T/T 5,5	33-2	11	8

* Single phase power input also available on request (1x220-240 V~).

MODEL	A	B	H	H2	H3	DNA	DNM	PACKING DIMENSIONS			VOLUME m ³	WEIGHT kg
								L/A	L/B	H		
3 KVC AD 30/50	750	900	740	100	710	2" 1/2	2" 1/2	1000	800	1400	1,2	131
3 KVC AD 55/50	750	900	740	100	710	2" 1/2	2" 1/2	1000	800	1400	1,2	141
3 KVC AD 75/50	750	900	740	100	710	2" 1/2	2" 1/2	1000	800	1400	1,2	150
3 KVC AD 30/80	750	900	740	100	710	2" 1/2	2" 1/2	1000	800	1400	1,2	136
3 KVC AD 40/80	750	900	740	100	710	2" 1/2	2" 1/2	1000	800	1400	1,2	145
3 KVC AD 45/80	750	900	740	100	710	2" 1/2	2" 1/2	1000	800	1400	1,2	150
3 KVC AD 55/80	750	900	740	100	710	2" 1/2	2" 1/2	1000	800	1400	1,2	152
3 KVC AD 65/80	750	900	740	100	710	2" 1/2	2" 1/2	1000	800	1400	1,2	156
3 KVC AD 35/120	750	900	740	100	710	2" 1/2	2" 1/2	1000	800	1400	1,2	150
3 KVC AD 45/120	750	900	740	100	710	2" 1/2	2" 1/2	1000	800	1400	1,2	156
3 KVC AD 60/120	750	900	740	100	710	2" 1/2	2" 1/2	1000	800	1400	1,2	162
3 KVC AD 70/120	750	900	740	100	710	2" 1/2	2" 1/2	1000	800	1400	1,2	168
3 KVC AD 85/120	750	900	740	100	710	2" 1/2	2" 1/2	1000	800	1400	1,2	170

The sets are supplied in a sturdy cardboard packaging on wooden pallet and installation / maintenance manual.

1/2/3 KV AD 3-6-10

DOMESTIC CONSTANT PRESSURE BOOSTER SETS WITH ACTIVE DRIVER PLUS

ACTIVE DRIVER PLUS
PAGE 166



TECHNICAL DATA

Operating range: from 1,8 to 43 m³/h

Pumped liquid: clean, free of solids and abrasives, non viscous, non aggressive, non crystallised and chemically neutral, with properties similar to water.

Pumped liquid temperature range: from 0 °C to +40°C

Maximum ambient temperature: +40°C

Maximum operating pressure: PN16

Special executions on request: contact our sales network

Protection class: IP44

APPLICATIONS

Pressure booster sets particularly suited for domestic use, small civil or industrial systems, irrigation systems, and washing systems. Their main features are reliability, simple operation, and minimum maintenance requirements.

CONSTRUCTION FEATURES - COMPONENTS

HYDRAULIC SECTION

KV multistage centrifugal electric pumps.

Galvanized sheet steel base complete with 4 rubber anti-vibration feet.

Suction and delivery manifolds in galvanized steel.

Ball valves with unions on the suction and delivery ports of each pump.

Check valves on the suction port of each pump.

2 galvanized steel plugs for closing the manifolds.

Radial manometer with isolator valve.

1 18 litre membrane pressure tank (it optimises the number of pump starts).

ELECTRICAL SECTION

1 Active Driver Plus module on the delivery line of each pump (see Active Driver Plus information at the beginning of this section).

1 protection control unit.

MULTI INVERTER SYSTEM WITH ACTIVE DRIVER PLUS

The inverter provides constant control of the rotation speed of the electric pump, ensuring constant pressure despite flow rate variations.

The other electric pumps, also with variable speed, are activated in cascade after the first one has reached maximum speed. Through modulation, they compensate the pressure fluctuations of the system. For every operating cycle, it is possible to switch the restart to a different pump, therefore ensuring even use of all electric pumps.

It is possible to set operation times for each individual pump, switching to another pump after such set times.

The "SP" pressure can be adjusted by the user using two "+" and "-" keys on the A.D. (as a rule, all the pumps are set to the same pressure value).

MATERIALS

N.	PARTS	MATERIALS
4	IMPELLER	TECHNOPOLYMER B
6	DIFFUSER	TECHNOPOLYMER B
7A	PUMP SHAFT	AISI 416 STAINLESS STEEL X12 CrS 13 UNI 6900/71
16	MECHANICAL SEAL	CARBON / CERAMIC
28	OR RING	EPDM RUBBER
69	LINER	AISI 304 STAINLESS STEEL X5 CrNi 1810 UNI 6900/71
95	OR RING	EPDM RUBBER
96	SUCTION BODY	CAST IRON 200 UNI ISO 185
97	DELIVERY BODY	CAST IRON 200 UNI ISO 185
98	DIFFUSER BODY	TECHNOPOLYMER B

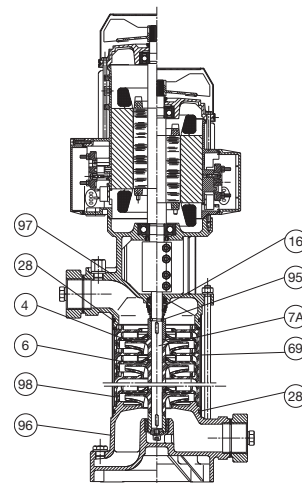

1 KV AD 3 - DOMESTIC PRESSURE BOOSTER SETS

Pumped liquid temperature range: from 0 °C to +40 °C - Maximum ambient temperature: +40 °C - Max flow rate: 7.2 m³/h

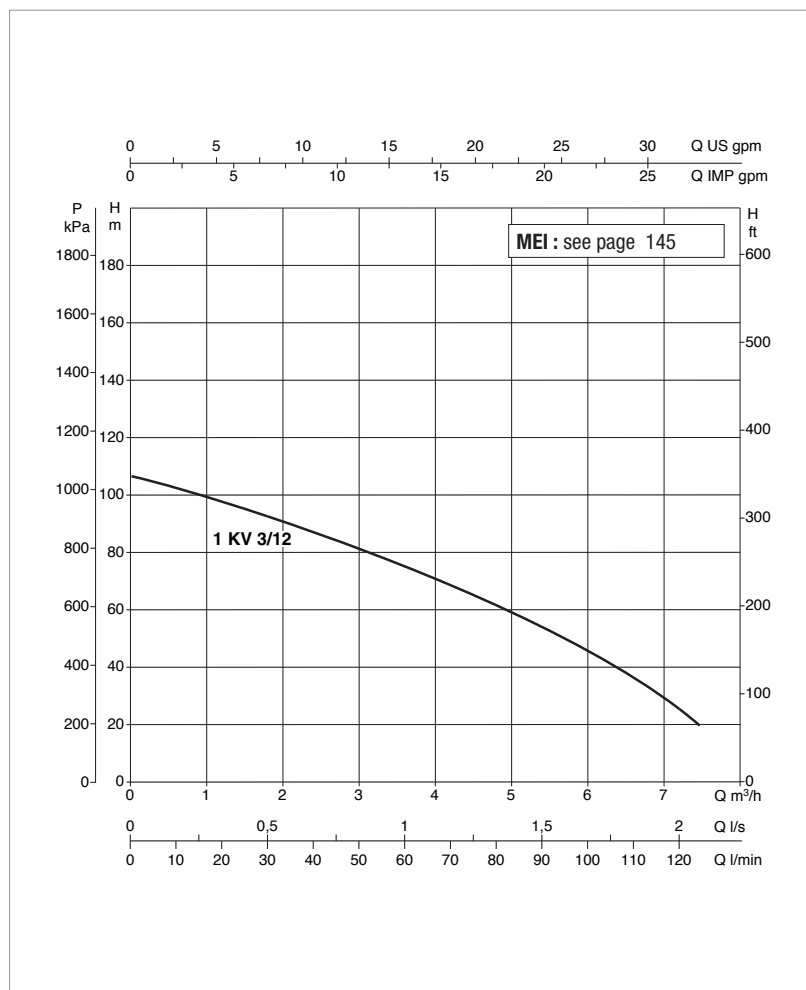
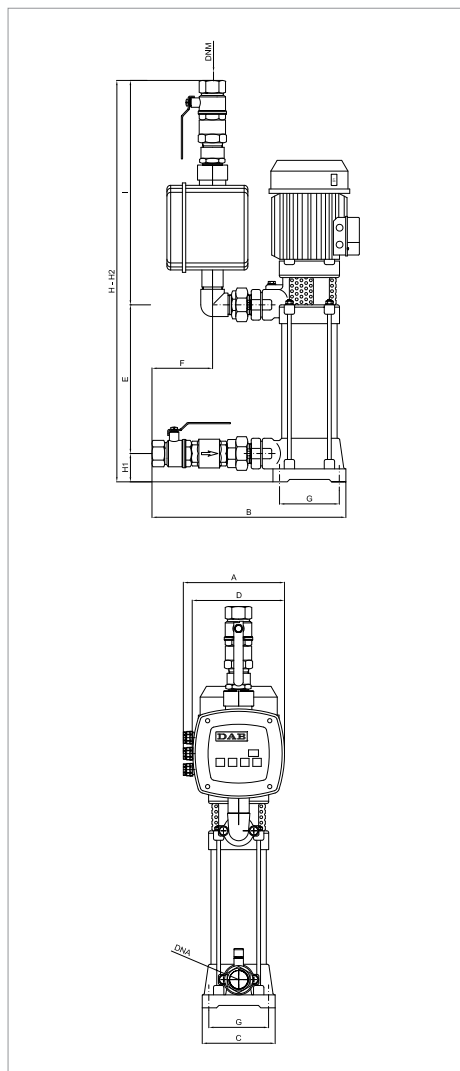

The performance curves are based on kinematic viscosity values = 1 mm²/s and density equal to 1000 kg/m³.
Curve tolerance according to ISO 9906.

MODEL	POWER INPUT 50 Hz	P2 NOMINAL		In A	INVERTER MODEL	MAX FLOW RATE m ³ /h	MAX OBTAINABLE PRESSURE	STANDARD PRESSURE
		kW	HP					
1 KV A.D. 3/12 M	1x230	1,5	2	8,5	A.D. M/T 2,2	7,2	10,5	6,5

MODEL	A	B	C	D	E	F	G	H	H1	H2	I	DNA	DNM	PACKING DIMENSIONS			VOLUME m ³	WEIGHT kg
														L/A	L/B	H		
1 KV A.D. 3/12 M	215	412	155	195	476	130	127	1016	60	1016	480	1"¼	1"¼	850	610	895	0,5	38

The sets are supplied in a sturdy cardboard packaging on wooden pallet and installation / maintenance manual.

1 KV AD 6 - DOMESTIC PRESSURE BOOSTER SETS

Pumped liquid temperature range: from 0 °C to +40 °C - Maximum ambient temperature: +40 °C - Max flow rate: 8.4 m³/h

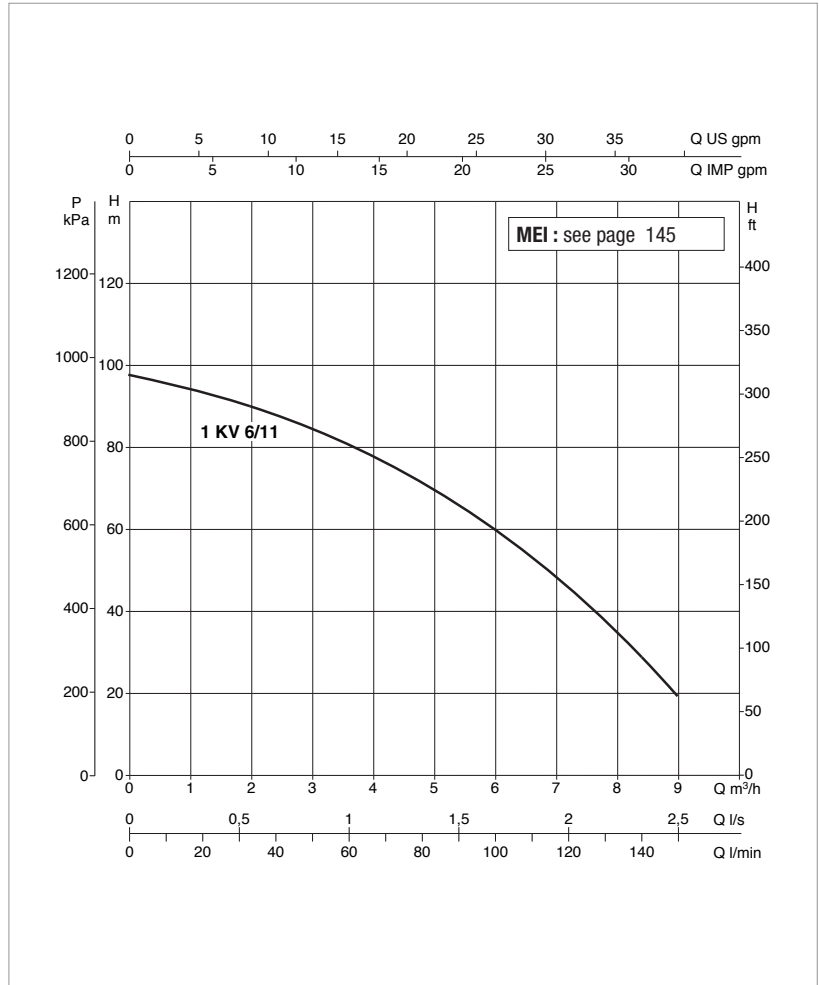
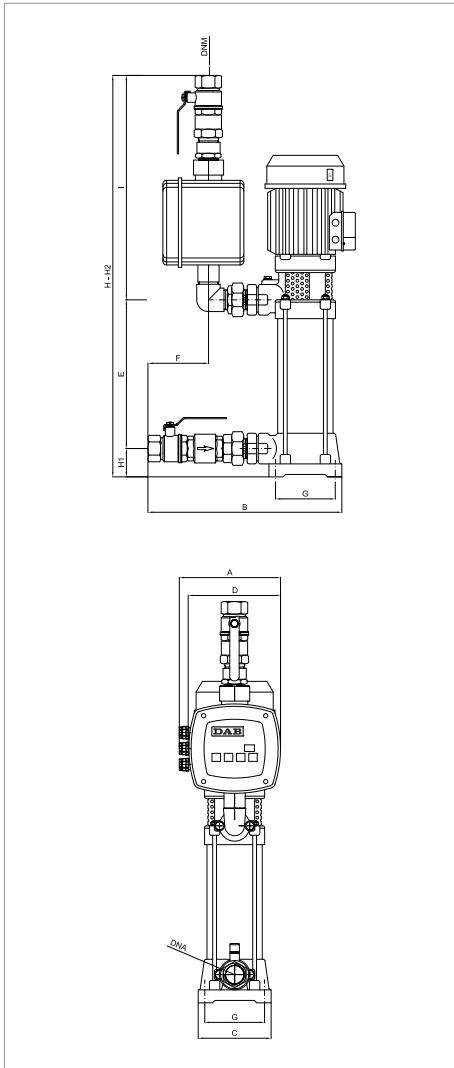

The performance curves are based on kinematic viscosity values = 1 mm²/s and density equal to 1000 kg/m³.
Curve tolerance according to ISO 9906.

MODEL	POWER INPUT 50 Hz	P2 NOMINAL		In A	INVERTER MODEL	MAX FLOW RATE m³/h	MAX OBTAINABLE PRESSURE	STANDARD PRESSURE
		kW	HP					
1 KV A.D. 6/11 M	1x230	1,85	2,5	9,5	A.D. M/T 2,2	8,4	9,8	5,5

MODEL	A	B	C	D	E	F	G	H	H1	H2	I	DNA	DNM	PACKING DIMENSIONS			VOLUME m³	WEIGHT kg
														L/A	L/B	H		
1 KV A.D. 6/11 M	215	412	155	195	444	130	127	984	60	984	480	1 1/4	1 1/4	850	610	895	0,5	41

The sets are supplied in a sturdy cardboard packaging on wooden pallet and installation / maintenance manual.

1 KV AD 10 - DOMESTIC PRESSURE BOOSTER SETS

Pumped liquid temperature range: from 0 °C to +40 °C - Maximum ambient temperature: +40 °C - Max flow rate: 13.8 m³/h

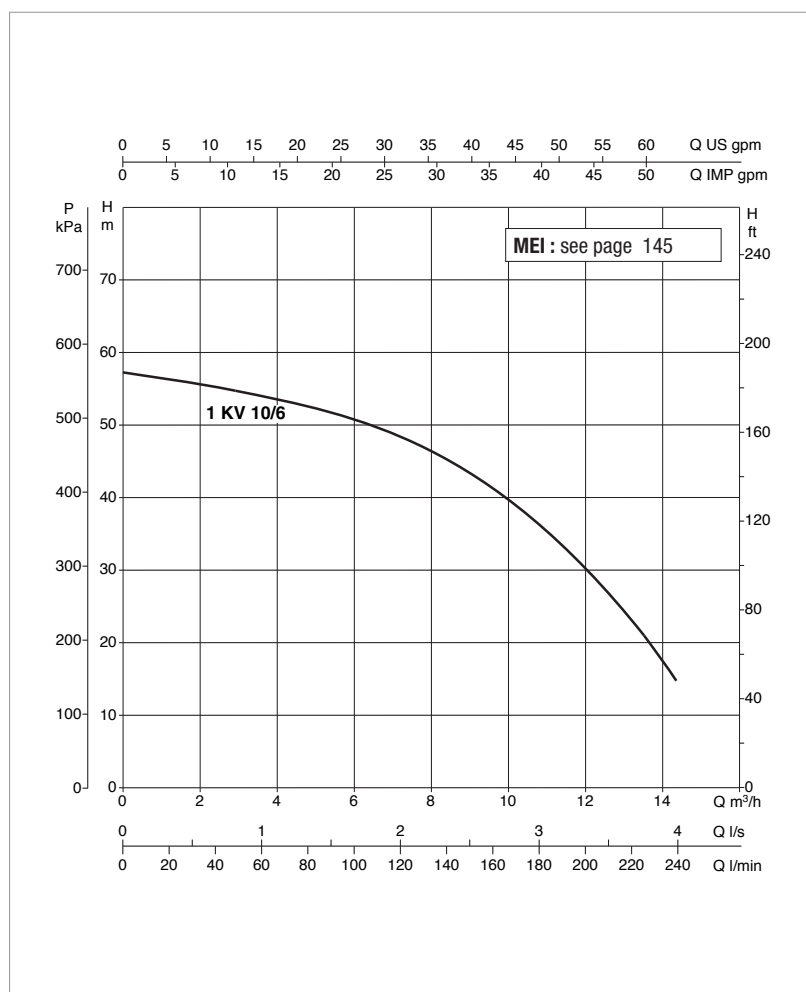
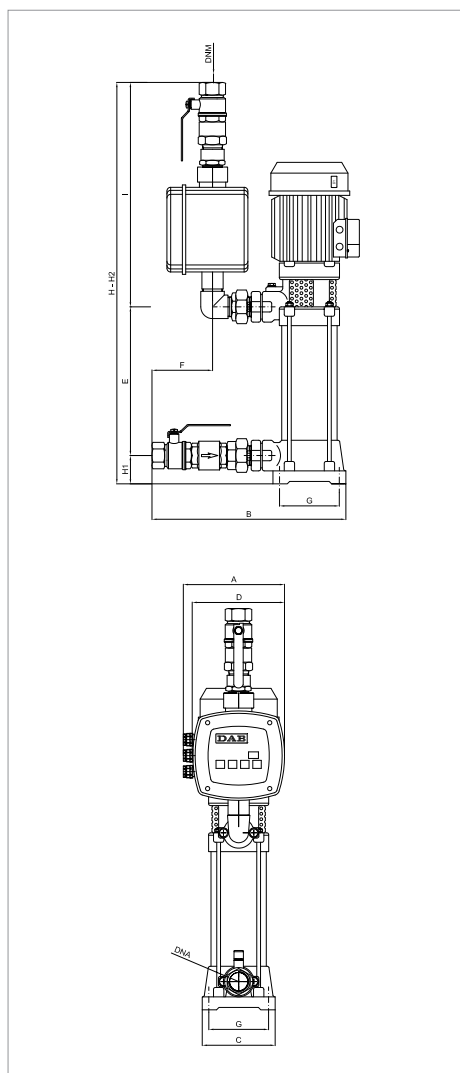

The performance curves are based on kinematic viscosity values = 1 mm²/s and density equal to 1000 kg/m³.
Curve tolerance according to ISO 9906.

MODEL	POWER INPUT 50 Hz	P2 NOMINAL		In A	INVERTER MODEL	MAX FLOW RATE m ³ /h	MAX OBTAINABLE PRESSURE	STANDARD PRESSURE
		kW	HP					
1 KV A.D. 10/6 M	1x230	1,85	2,5	9,5	A.D. M/T 2,2	13,8	5,7	4,5

MODEL	A	B	C	D	E	F	G	H	H1	H2	I	DNA	DNM	PACKING DIMENSIONS			VOLUME m ³	WEIGHT kg
														L/A	L/B	H		
1 KV A.D. 10/6 M	215	412	155	195	284	130	127	984	60	824	480	1"¼	1"¼	850	610	895	0,5	41

The sets are supplied in a sturdy cardboard packaging on wooden pallet and installation / maintenance manual.

2 KV AD 3 - DOMESTIC PRESSURE BOOSTER SETS

Pumped liquid temperature range: from 0 °C to +40 °C - Maximum ambient temperature: +40 °C - Max flow rate: 14.4 m³/h

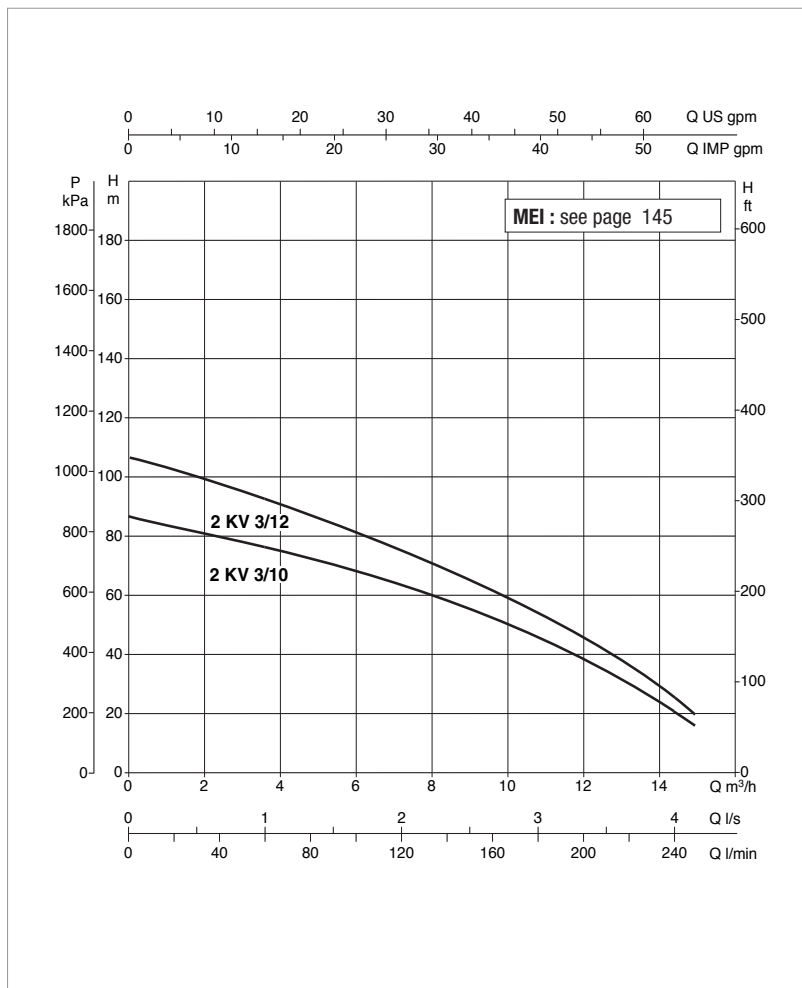
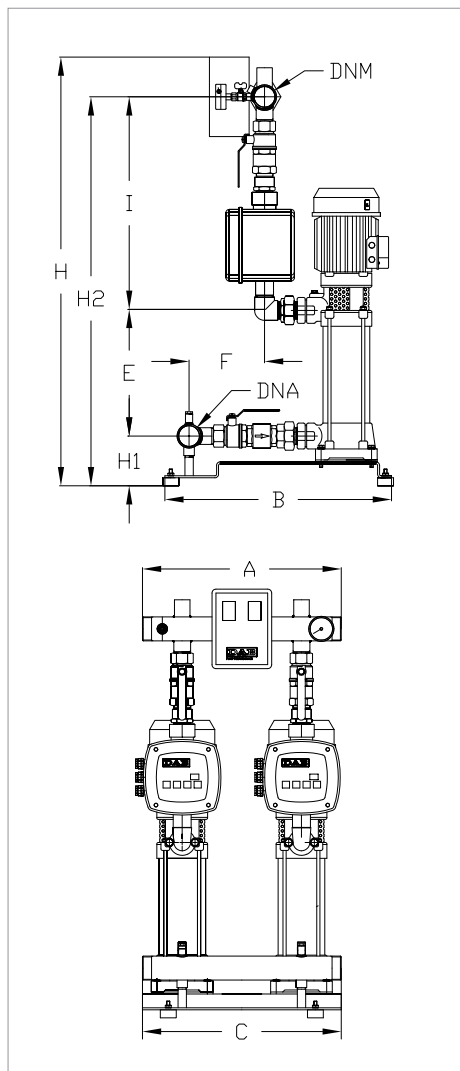

The performance curves are based on kinematic viscosity values = 1 mm²/s and density equal to 1000 kg/m³. Curve tolerance according to ISO 9906. **Overall performance taking into account TWO pumps working at the same time.** The performance results of sets with smaller pumps are obtained through simple calibration of the Active Driver Plus module.

MODEL	POWER INPUT 50 Hz	P2 NOMINAL		In A	INVERTER MODEL	MAX FLOW RATE m ³ /h	MAX OBTAINABLE PRESSURE	STANDARD PRESSURE
		kW	HP					
2 KV A.D. 3/10 T / N	3x400+N	2x1,1	2x1,5	2x7,3	A.D. MT 2,2	14,4	8,8	6,5
2 KV A.D. 3/12 T / N	3x400+N	2x1,5	2x2	2x8,3	A.D. MT 2,2	14,4	10,5	8,5

MODEL	A	B	C	E	F	H	H1	H2	I	DNA	DNM	PACKING DIMENSIONS			VOLUME m ³	WEIGHT kg
												L/A	L/B	H		
2 KV A.D. 3/10 T / N	500	570	500	412	190	967	125	947	535	2"	2"	1000	610	1280	0,8	78
2 KV A.D. 3/12 T / N	500	570	500	476	190	1031	125	1011	535	2"	2"	1000	610	1280	0,8	86,5

The sets are supplied in a sturdy cardboard packaging on wooden pallet and installation / maintenance manual.

2 KV AD 6 - DOMESTIC PRESSURE BOOSTER SETS

Pumped liquid temperature range: from 0 °C to +40 °C - Maximum ambient temperature: +40 °C - Max flow rate: 17 m³/h

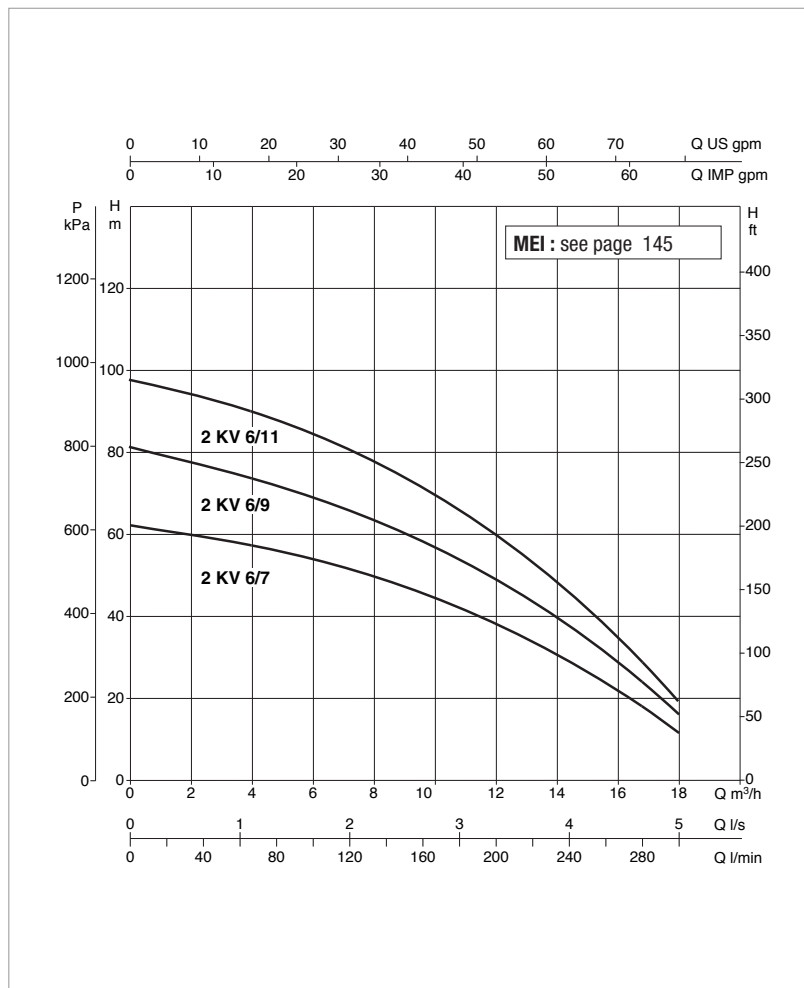
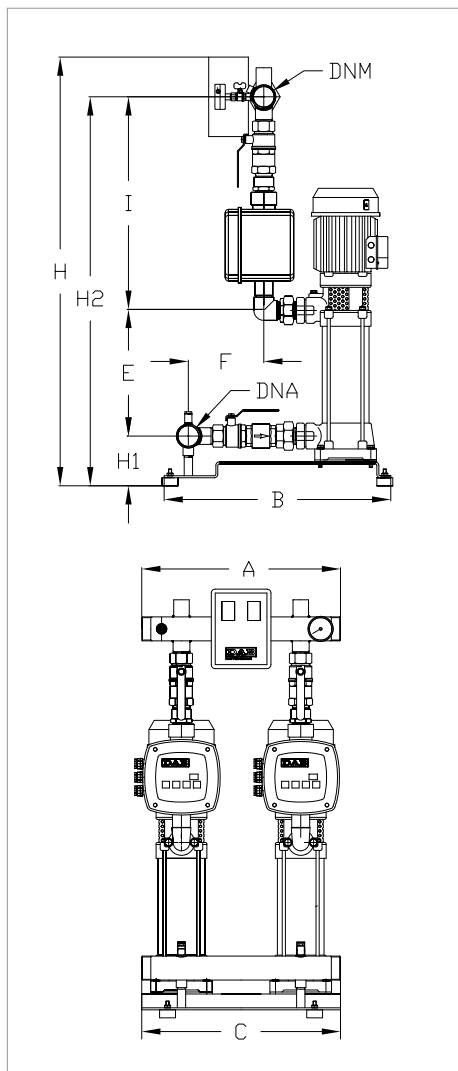

The performance curves are based on kinematic viscosity values = 1 mm²/s and density equal to 1000 kg/m³.
Curve tolerance according to ISO 9906. **Overall performance taking into account TWO pumps working at the same time.**
The performance results of sets with smaller pumps are obtained through simple calibration of the Active Driver Plus module.

MODEL	POWER INPUT 50 Hz	P2 NOMINAL		In A	INVERTER MODEL	MAX FLOW RATE m ³ /h	MAX OBTAINABLE PRESSURE	STANDARD PRESSURE
		kW	HP					
2 KV A.D. 6/7 T / N	3x400+N	2x1,1	2x1,5	2x7,3	A.D. MT 2,2	17	6,2	4
2 KV A.D. 6/9 T / N	3x400+N	2x1,5	2x2	2x8,3	A.D. MT 2,2	17	8	6
2 KV A.D. 6/11 T / N	3x400+N	2x1,85	2x2,5	2x9,5	A.D. MT 2,2	17	9,8	7

MODEL	A	B	C	E	F	H	H1	H2	I	DNA	DNM	PACKING DIMENSIONS			VOLUME m ³	WEIGHT kg
												L/A	L/B	H		
2 KV A.D. 6/7 T / N	500	570	500	316	190	871	125	851	535	2"	2"	1000	610	1280	0,8	86,5
2 KV A.D. 6/9 T / N	500	570	500	380	190	935	125	915	535	2"	2"	1000	610	1280	0,8	87
2 KV A.D. 6/11 T / N	500	570	500	444	190	999	125	979	535	2"	2"	1000	610	1280	0,8	86,5

The sets are supplied in a sturdy cardboard packaging on wooden pallet and installation / maintenance manual.

2 KV AD 10 - DOMESTIC PRESSURE BOOSTER SETS

Pumped liquid temperature range: from 0 °C to +40 °C - Maximum ambient temperature: +40 °C - Max flow rate: 27 m³/h

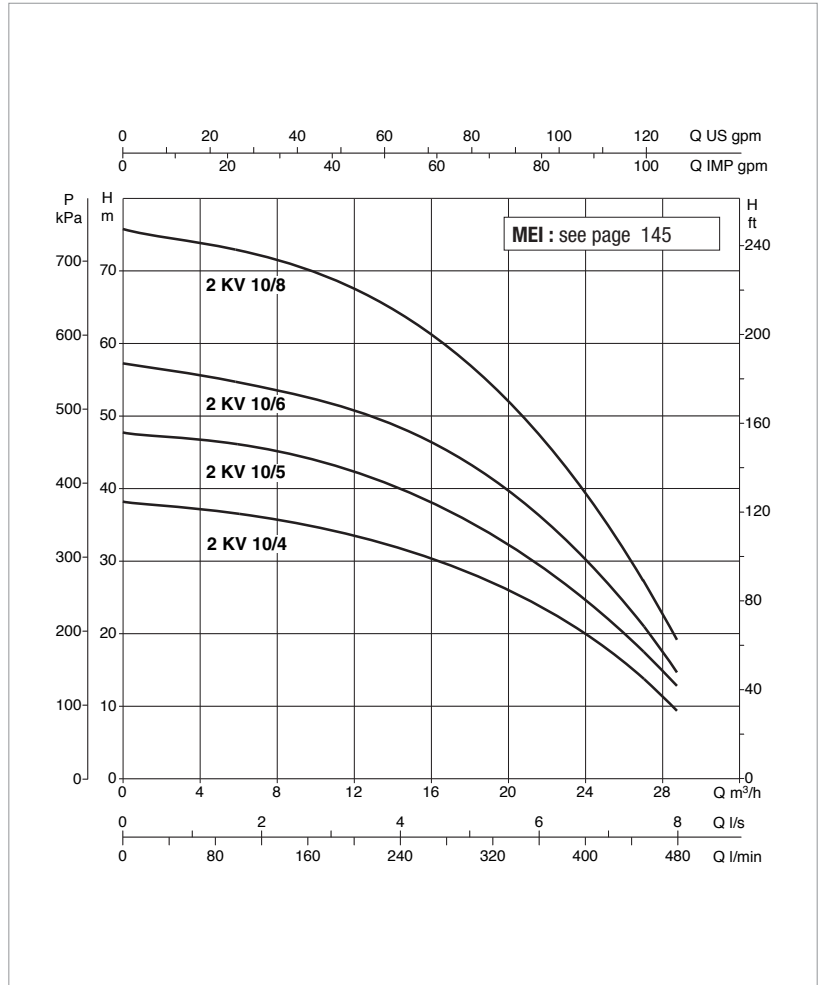
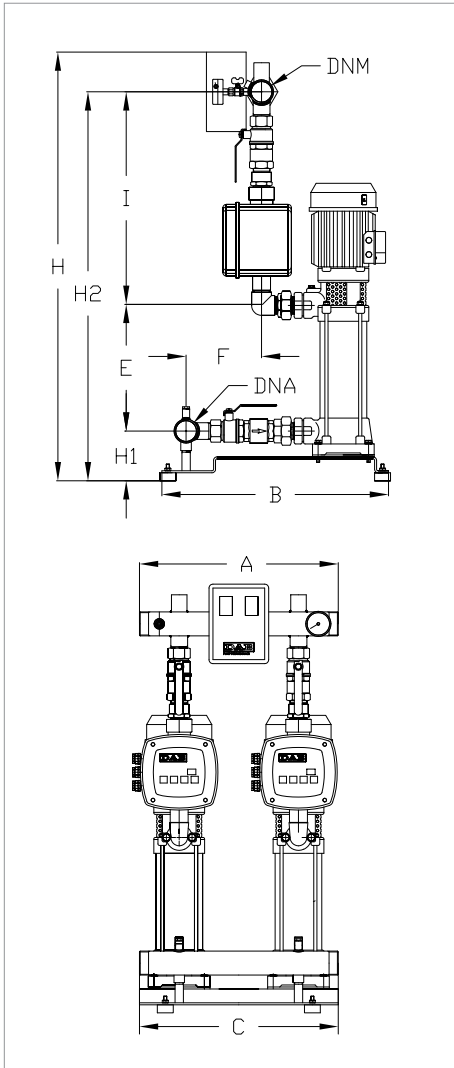

The performance curves are based on kinematic viscosity values = 1 mm²/s and density equal to 1000 kg/m³. Curve tolerance according to ISO 9906. **Overall performance taking into account TWO pumps working at the same time.** The performance results of sets with smaller pumps are obtained through simple calibration of the Active Driver Plus module.

MODEL	POWER INPUT 50 Hz	P2 NOMINAL		In A	INVERTER MODEL	MAX FLOW RATE m ³ /h	MAX OBTAINABLE PRESSURE	STANDARD PRESSURE
		KW	HP					
2 KV A.D. 10/4 T / N	3x400+N	2x1,1	2x1,5	2x7,3	A.D. MT 2,2	27	3,8	3
2 KV A.D. 10/5 T / N	3x400+N	2x1,5	2x2	2x8,3	A.D. MT 2,2	27	4,8	4
2 KV A.D. 10/6 T / N	3x400+N	2x1,85	2x2,5	2x9,5	A.D. MT 2,2	27	5,7	4,5
2 KV A.D. 10/8 T	3x400	2x2,2	2x3	2x8,8	A.D. T/T 3,0	27	7,6	6

MODEL	A	B	C	E	F	H	H1	H2	I	DNA	DNM	PACKING DIMENSIONS			VOLUME m ³	WEIGHT kg
												L/A	L/B	H		
2 KV A.D. 10/4 T / N	500	570	500	220	190	775	125	755	535	2"	2"	1000	610	1280	0,8	87
2 KV A.D. 10/5 T / N	500	570	500	252	190	807	125	787	535	2"	2"	1000	610	1280	0,8	90
2 KV A.D. 10/6 T / N	500	570	500	284	190	839	125	819	535	2"	2"	1000	610	1280	0,8	93
2 KV A.D. 10/8 T	500	570	500	348	190	903	125	883	535	2"	2"	1000	610	1280	0,8	101

The sets are supplied in a sturdy cardboard packaging on wooden pallet and installation / maintenance manual.

3 KV AD 3 - DOMESTIC PRESSURE BOOSTER SETS

Pumped liquid temperature range: from 0 °C to +40 °C - Maximum ambient temperature: +40 °C - Max flow rate: 21.5 m³/h

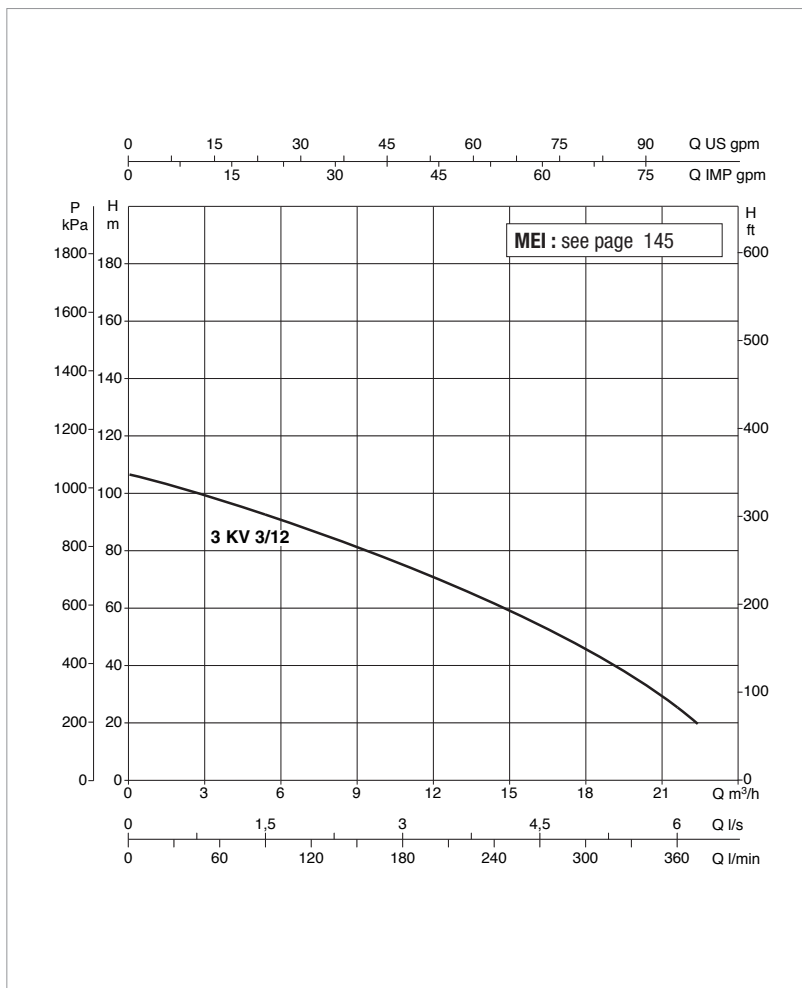
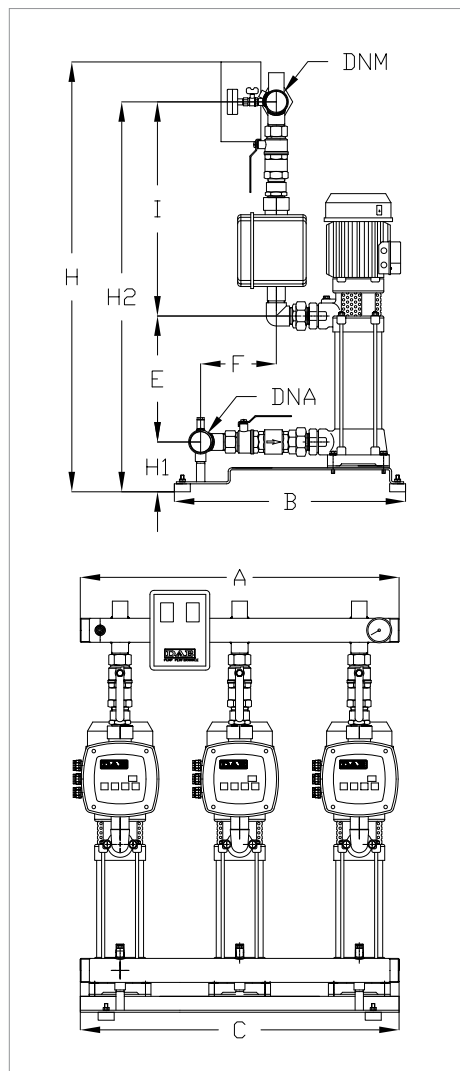

The performance curves are based on kinematic viscosity values = 1 mm²/s and density equal to 1000 kg/m³. Curve tolerance according to ISO 9906. **Overall performance taking into account THREE pumps working at the same time.** The performance results of sets with smaller pumps are obtained through simple calibration of the Active Driver Plus module.

MODEL	POWER INPUT 50 Hz	P2 NOMINAL		In A	INVERTER MODEL	MAX FLOW RATE m³/h	MAX OBTAINABLE PRESSURE	STANDARD PRESSURE
		kW	HP					
3 KV A.D. 3/12 T / N	3x400+N	3x1,5	3x2	3x8,3	A.D. M/T 2,2	21,5	7,2	6

MODEL	A	B	C	E	F	H	H1	H2	I	DNA	DNM	PACKING DIMENSIONS			VOLUME m³	WEIGHT kg
												L/A	L/B	H		
3 KV A.D. 3/12 T / N	800	570	800	476	205	1056	130	1026	550	80	80	1150	888	1300	1,35	172

The sets are supplied in a sturdy cardboard packaging on wooden pallet and installation / maintenance manual.

3 KV AD 6 - DOMESTIC PRESSURE BOOSTER SETS

Pumped liquid temperature range: from 0 °C to +40 °C - Maximum ambient temperature: +40 °C - Max flow rate: 25 m³/h

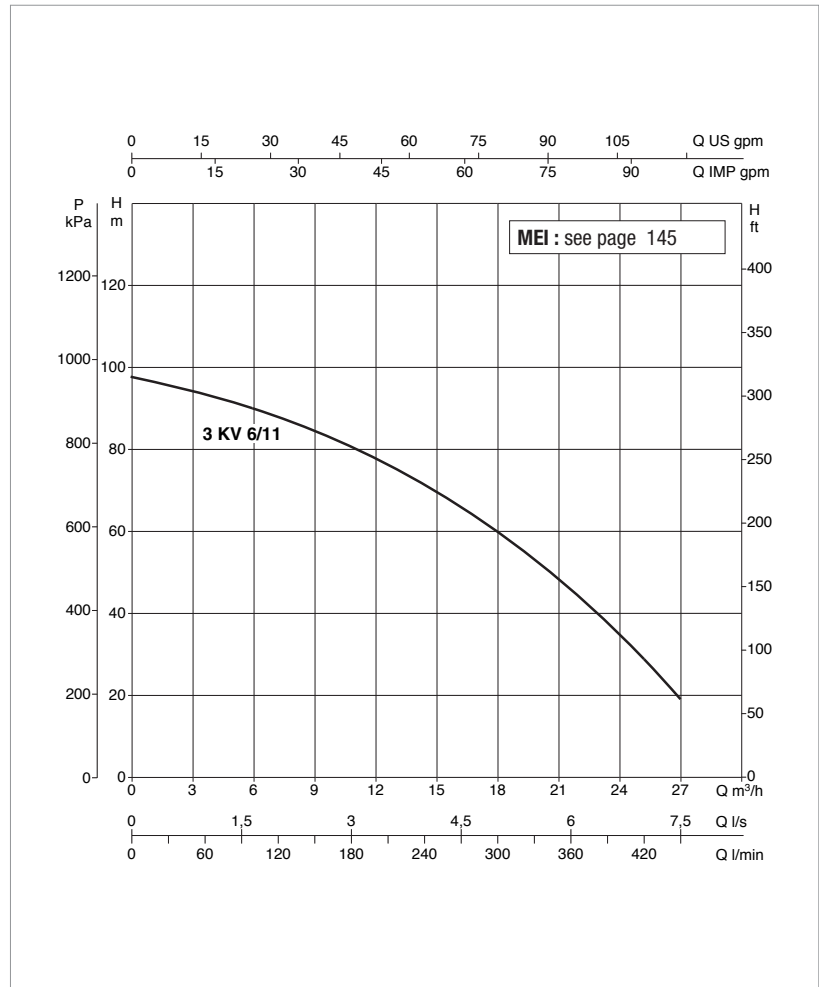
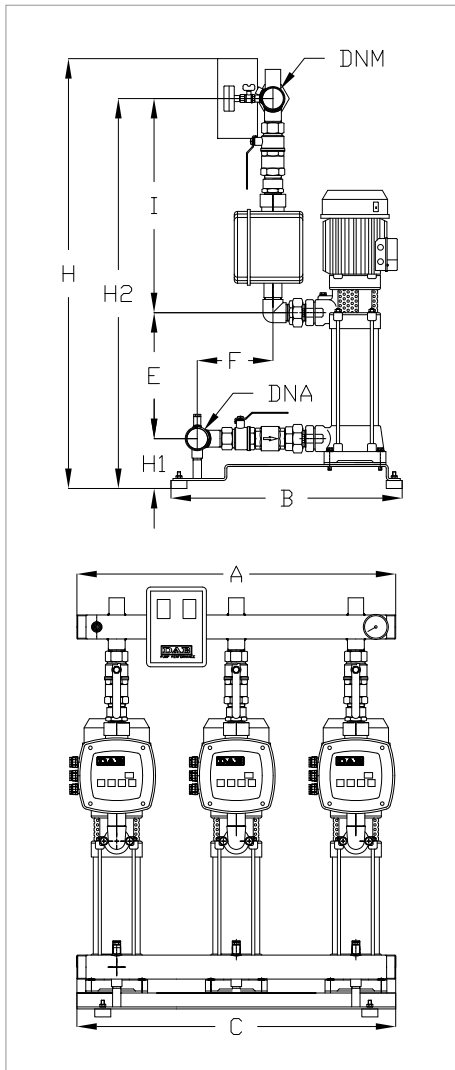

The performance curves are based on kinematic viscosity values = 1 mm²/s and density equal to 1000 kg/m³. Curve tolerance according to ISO 9906. **Overall performance taking into account THREE pumps working at the same time.** The performance results of sets with smaller pumps are obtained through simple calibration of the Active Driver Plus module.

MODEL	POWER INPUT 50 Hz	P2 NOMINAL		In A	INVERTER MODEL	MAX FLOW RATE m ³ /h	MAX OBTAINABLE PRESSURE	STANDARD PRESSURE
		kW	HP					
3 KV A.D. 6/11 T / N	3x400+N	3x1,85	3x2,5	3x9,5	A.D. M/T 2,2	25	8,4	7,5

MODEL	A	B	C	E	F	H	H1	H2	I	DNA	DNM	PACKING DIMENSIONS			VOLUME m ³	WEIGHT kg
												L/A	L/B	H		
3 KV A.D. 6/11 T / N	800	570	800	444	205	1024	130	994	550	80	80	1150	888	1300	1,35	173

The sets are supplied in a sturdy cardboard packaging on wooden pallet and installation / maintenance manual.

3 KV AD 10 - DOMESTIC PRESSURE BOOSTER SETS

Pumped liquid temperature range: from 0 °C to +40 °C - Maximum ambient temperature: +40 °C - Max flow rate: 41 m³/h

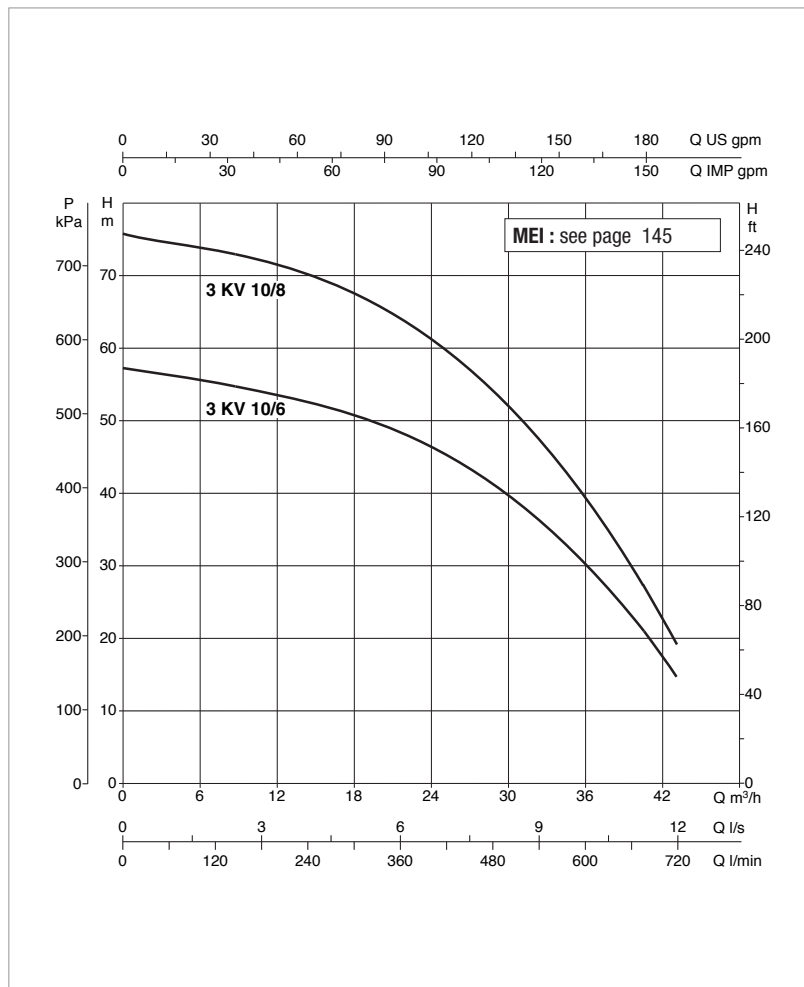
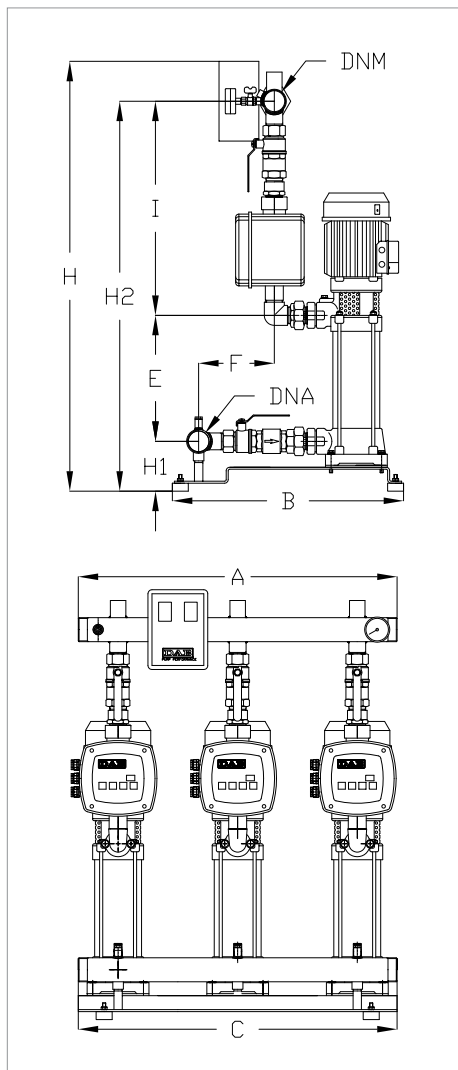

The performance curves are based on kinematic viscosity values = 1 mm²/s and density equal to 1000 kg/m³.
Curve tolerance according to ISO 9906. **Overall performance taking into account THREE pumps working at the same time.**
The performance results of sets with smaller pumps are obtained through simple calibration of the Active Driver Plus module.

MODEL	POWER INPUT 50 Hz	P2 NOMINAL		In A	INVERTER MODEL	MAX FLOW RATE m ³ /h	MAX OBTAINABLE PRESSURE	STANDARD PRESSURE
		kW	HP					
3 KV A.D. 10/6 T / N	3x400+N	3x1,85	3x2,5	3x9,5	A.D. M/T 2,2	41	5,7	4,5
3KV A.D. 10/8 T	3x400	3x2,2	3x3	3x8,8	A.D. T/T 3,0	41	7,6	6

MODEL	A	B	C	E	F	H	H1	H2	I	DNA	DNM	PACKING DIMENSIONS			VOLUME m ³	WEIGHT kg
												L/A	L/B	H		
3 KV A.D. 10/6 T / N	800	570	800	284	205	864	130	834	550	80	80	1150	888	1300	1,35	178
3KV A.D. 10/8 T	800	570	800	348	205	928	130	898	550	80	80	1150	888	1300	1,35	194

The sets are supplied in a sturdy cardboard packaging on wooden pallet and installation / maintenance manual.

2-3 NKV AD 10-15

CONSTANT PRESSURE RESIDENTIAL SETS WITH ACTIVE DRIVER PLUS

ACTIVE DRIVER PLUS
PAGE 166

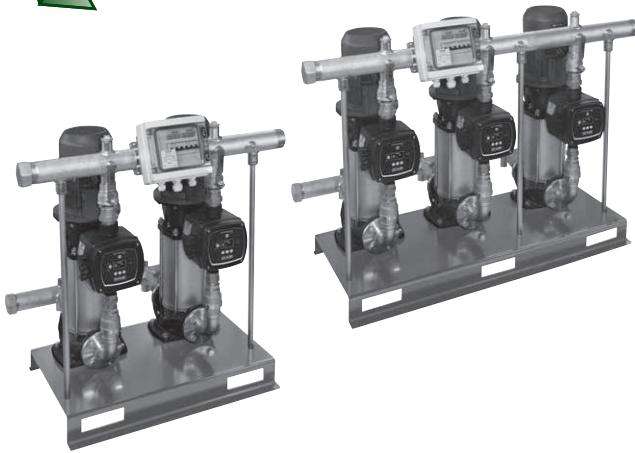

TECHNICAL DATA

Operating range: from 4 to 45 m³/h

Pumped liquid: clean, free of solids and abrasives, non viscous, non aggressive, non crystallised and chemically neutral, with properties similar to water.

Pumped liquid temperature range: from 0 °C to +50 °C for domestic use

Maximum ambient temperature: +40°C

Maximum operating pressure: PN16

Special executions on request: contact our sales network

Protection class: IP44

APPLICATIONS

Pressure booster sets particularly suited for civil or industrial use, irrigation systems and washing systems. Their main features are reliability, simple operation, and minimum maintenance requirements.

CONSTRUCTION FEATURES

HYDRAULIC SECTION

NKV 10-15 vertical multistage centrifugal electric pumps.

Galvanised metal sheet base.

Suction and delivery manifolds in galvanized steel (stainless steel on request).

Ball valves with unions on the suction and delivery ports of each pump.

Check valves on the suction port of each pump.

2 galvanized steel plugs or blind flanges for closing the manifolds.

Radial manometer with isolator valve.

1 8 litre membrane tank.

ELECTRICAL SECTION

1 Active Driver Plus module on the delivery of each pump.

1 protection control unit.

MULTI INVERTER SYSTEM WITH ACTIVE DRIVER PLUS

The inverter provides constant control of the rotation speed of the electric pump, ensuring constant pressure despite flow rate variations.

The other electric pumps, also with variable speed, are activated in cascade after the first one has reached maximum speed. Through modulation, they compensate the pressure fluctuations of the system.

For every operating cycle, it is possible to switch the restart to a different pump, therefore ensuring even use of all electric pumps.

It is possible to set operation times for each individual pump, switching to another pump after such set times.

The "SP" pressure can be adjusted by the user using two "+" and "-" keys on the A.D. (as a rule, all the pumps are set to the same pressure value).

MATERIALS

N.	PARTS	MATERIALS *
1	EXTERNAL PUMP BODY	CATAPHORESIS TREATED CAST IRON
	INTERNAL PUMP BODY*	AISI 304 STAINLESS STEEL
3	SUPPORT	CATAPHORESIS TREATED CAST IRON
4	IMPELLER*	AISI 304 STAINLESS STEEL
6	DIFFUSER*	"ULTEM" TECHNOPOLYMER
7A	PUMP SHAFT*	AISI 431 STAINLESS STEEL
16	MECHANICAL SEAL*	SiC/GRAPHITE/EPDM CARTRIDGE
69	OUTER LINER	AISI 304 STAINLESS STEEL

* In contact with the liquid

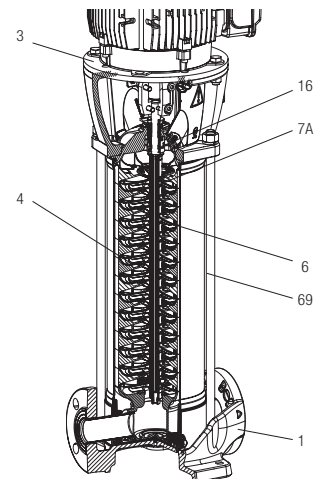

2 NKV AD 10 - RESIDENTIAL CONSTANT PRESSURE BOOSTER SETS

Pumped liquid temperature range: from 0 °C to +50 °C - Maximum ambient temperature: +40 °C - Max flow rate: 26 m³/h

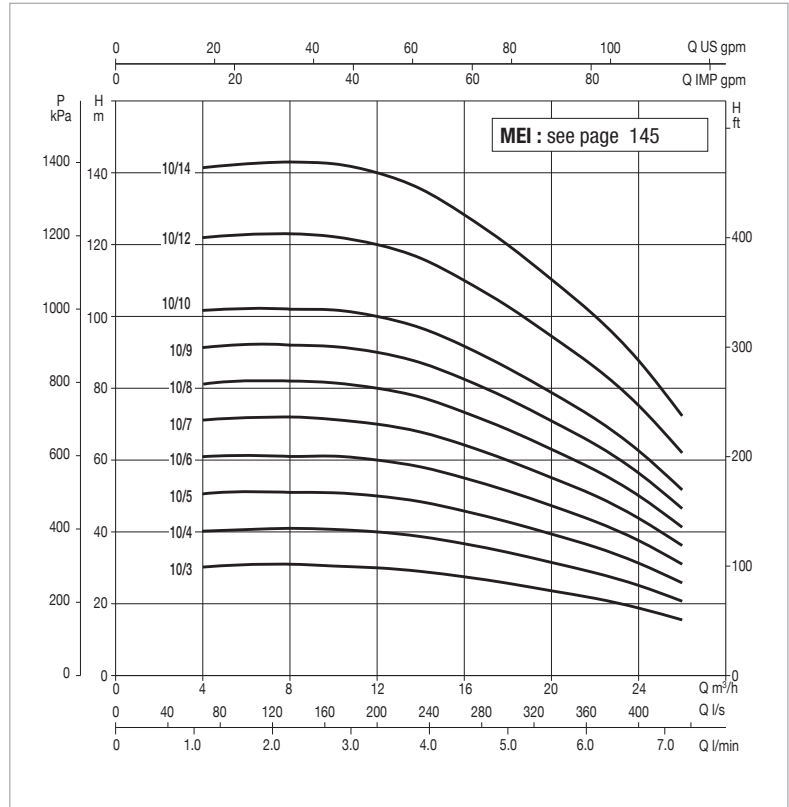
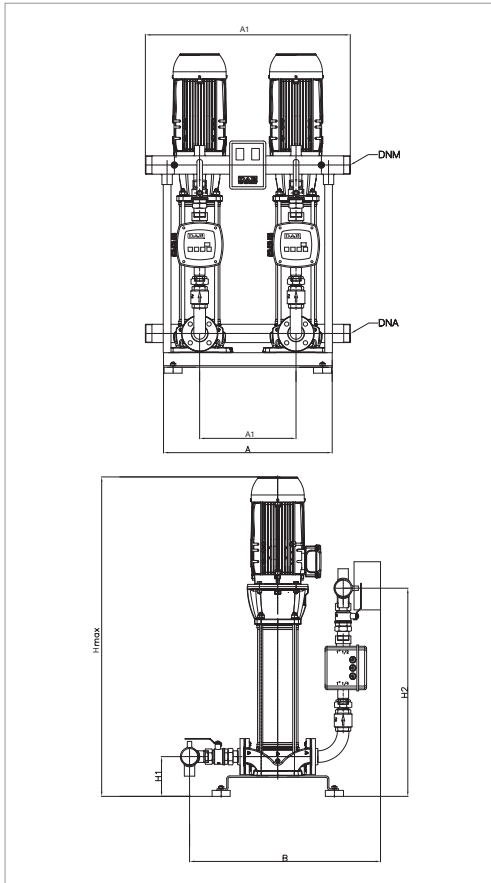

The performance curves are based on kinematic viscosity values = 1 mm²/s and density equal to 1000 kg/m³.
Curve tolerance according to ISO 9906.

Overall performance taking into account TWO pumps working at the same time.

MODEL	POWER INPUT 50 Hz	P2 NOMINAL		In A	ACTIVE DRIVER PLUS MODEL	FLOW m ³ /h	MAX OBTAINABLE PRESSURE	STANDARD PRESSURE BAR
		kW	HP					
2 NKV AD 10/3	1x220-240 V	2x1,1	2x1,5	2x7,5	M/T 2,2	26 - 4	3	2,5
2 NKV AD 10/4	1x220-240 V	2x1,5	2x2	2x9,6	M/T 2,2	26 - 4	4	3,0
2 NKV AD 10/5	3x400 V	2x2,2	2x3	2x4,7	T/T 3,0	26 - 4	5	4,0
2 NKV AD 10/6	3x400 V	2x2,2	2x3	2x4,7	T/T 3,0	26 - 4	6	5,0
2 NKV AD 10/7	3x400 V	2x3	2x4	2x5,8	T/T 3,0	26 - 4	7	6
2 NKV AD 10/8	3x400 V	2x3	2x4	2x5,8	T/T 3,0	26 - 4	8	6,5
2 NKV AD 10/9	3x400 V	2x3	2x4	2x5,8	T/T 3,0	26 - 4	9	7,7
2 NKV AD 10/10	3x400 V	2x4	2x5,5	2x7,6	T/T 5,5	26 - 4	10	8,5
2 NKV AD 10/12	3x400 V	2x4	2x5,5	2x7,6	T/T 5,5	26 - 4	12	10
2 NKV AD 10/14	3x400 V	2x5,5	2x7,5	2x11	T/T 5,5	26 - 4	14	12

MODEL	A	B	A1	C	H1	H2	H max	DNA	DNM	PACKING DIMENSIONS			VOLUME m ³	WEIGHT kg
										L/A	L/B	H		
2 NKV AD 10/3	800	850	900	400	180	940	1095	2" 1/2	2" 1/2	1000	1000	1400	1,4	258
2 NKV AD 10/4	800	850	900	400	180	940	1095	2" 1/2	2" 1/2	1000	1000	1400	1,4	268
2 NKV AD 10/5	800	850	900	400	180	940	1095	2" 1/2	2" 1/2	1000	1000	1400	1,4	276
2 NKV AD 10/6	800	850	900	400	180	940	1095	2" 1/2	2" 1/2	1000	1000	1400	1,4	278
2 NKV AD 10/7	800	850	900	400	180	940	1095	2" 1/2	2" 1/2	1000	1000	1400	1,4	298
2 NKV AD 10/8	800	850	900	400	180	940	1095	2" 1/2	2" 1/2	1000	1000	1400	1,4	300
2 NKV AD 10/9	800	850	900	400	180	940	1095	2" 1/2	2" 1/2	1000	1000	1400	1,4	302
2 NKV AD 10/10	800	850	900	400	180	940	1143	2" 1/2	2" 1/2	1000	1000	1400	1,4	322
2 NKV AD 10/12	800	850	900	400	180	940	1209	2" 1/2	2" 1/2	1000	1000	1400	1,4	326
2 NKV AD 10/14	800	850	900	400	180	940	1405	2" 1/2	2" 1/2	1000	1000	2000	1,4	382

The sets are supplied in a sturdy cardboard packaging on wooden pallet and installation / maintenance manual.

2 NKV AD 15 - RESIDENTIAL CONSTANT PRESSURE BOOSTER SETS

Pumped liquid temperature range: from 0 °C to +50 °C - Maximum ambient temperature: +40 °C - Max flow rate: 30 m³/h

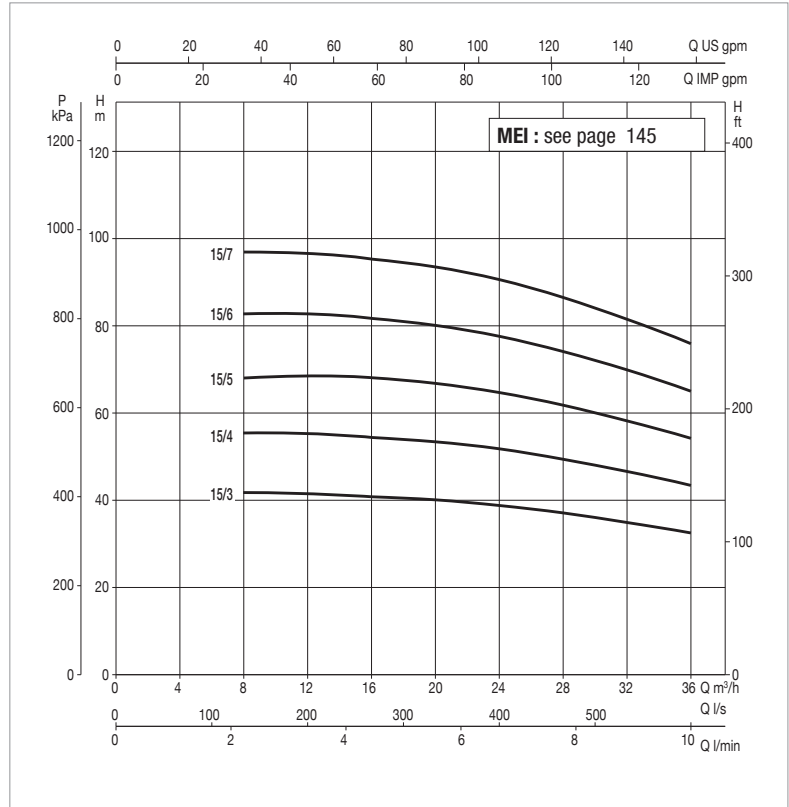
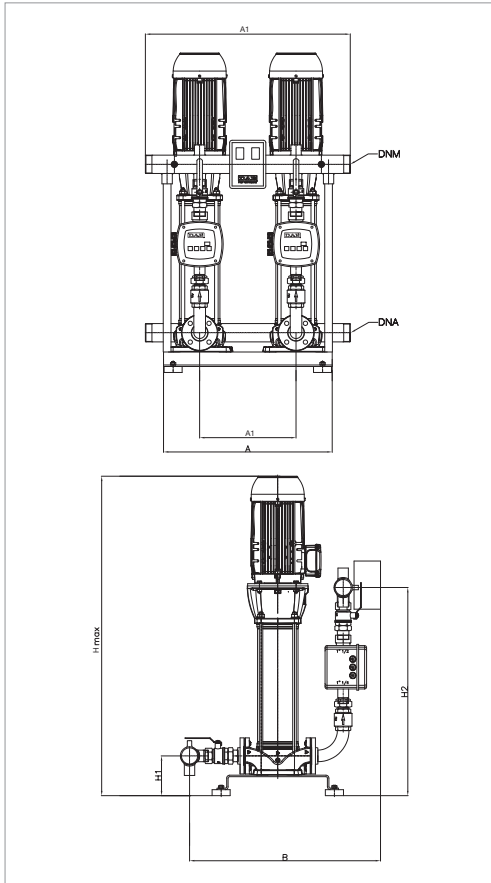

The performance curves are based on kinematic viscosity values = 1 mm²/s and density equal to 1000 kg/m³.
Curve tolerance according to ISO 9906.

Overall performance taking into account TWO pumps working at the same time.

MODEL	POWER INPUT 50 Hz	P2 NOMINAL		In A	ACTIVE DRIVER PLUS MODEL	FLOW m ³ /h	MAX OBTAINABLE PRESSURE BAR	STANDARD PRESSURE BAR
		kW	HP					
2 NKV AD 15/3	3x400 V	2x3	2x4	2x5,8	T/T 3,0	30 - 8	4	3,5
2 NKV AD 15/4	3x400 V	2x4	2x5,5	2x7,6	T/T 5,5	30 - 8	5	4
2 NKV AD 15/5	3x400 V	2x4	2x5,5	2x7,6	T/T 5,5	30 - 8	6,5	5
2 NKV AD 15/6	3x400 V	2x5,5	2x7,5	2x11	T/T 5,5	30 - 8	7,5	6,5
2 NKV AD 15/7	3x400 V	2x5,5	2x7,5	2x11	T/T 5,5	30 - 8	9	8

MODEL	A	B	A1	C	H1	H2	H max	DNA	DNM	PACKING DIMENSIONS			VOLUME m ³	WEIGHT kg
										L/A	L/B	H		
2 NKV AD 15/3	800	850	900	400	190	1000	1160	DN100	DN80	1000	1000	1400	1,4	314
2 NKV AD 15/4	800	850	900	400	190	1000	1160	DN100	DN80	1000	1000	1400	1,4	334
2 NKV AD 15/5	800	850	900	400	190	1000	1160	DN100	DN80	1000	1000	1400	1,4	336
2 NKV AD 15/6	800	850	900	400	190	1000	1320	DN100	DN80	1000	1000	1400	1,4	392
2 NKV AD 15/7	800	850	900	400	190	1000	1355	DN100	DN80	1000	1000	1400	1,4	395

The sets are supplied in a sturdy cardboard packaging on wooden pallet and installation / maintenance manual.

3 NKV AD 10 - RESIDENTIAL CONSTANT PRESSURE BOOSTER SETS

Pumped liquid temperature range: from 0 °C to +50 °C - Maximum ambient temperature: +40 °C - Max flow rate: 36 m³/h

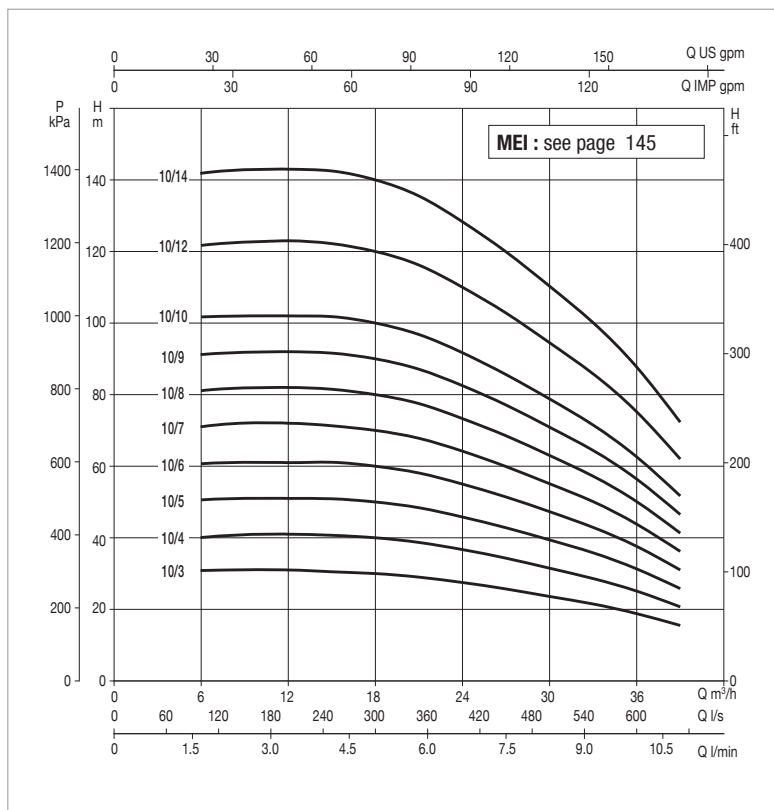
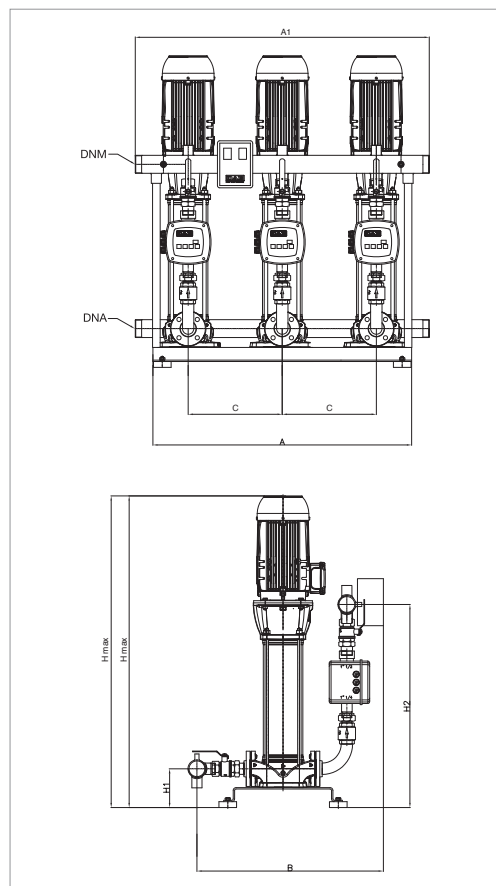

The performance curves are based on kinematic viscosity values = 1 mm²/s and density equal to 1000 kg/m³.
Curve tolerance according to ISO 9906.

Overall performance taking into account THREE pumps working at the same time.

MODEL	POWER INPUT 50 Hz	P2 NOMINAL		In A	ACTIVE DRIVER PLUS MODEL	FLOW m ³ /h	MAX OBTAINABLE PRESSURE BAR	STANDARD PRESSURE BAR
		KW	HP					
3NKV AD 10/3	1x220-240 V	3x1,1	3x1,5	3x7,5	MT 2,2	36 - 4	3	2,5
3NKV AD 10/4	1x220-240 V	3x1,5	3x2	3x9,6	MT 2,2	36 - 4	4	3,0
3NKV AD 10/5	3x400 V	3x2,2	3x3	3x4,7	T/T 3,0	36 - 4	5	4,0
3NKV AD 10/6	3x400 V	3x2,2	3x3	3x4,7	T/T 3,0	36 - 4	6	5,0
3NKV AD 10/7	3x400 V	3x3	3x4	3x5,8	T/T 3,0	36 - 4	7	6
3NKV AD 10/8	3x400 V	3x3	3x4	3x5,8	T/T 3,0	36 - 4	8	6,5
3NKV AD 10/9	3x400 V	3x3	3x4	3x5,8	T/T 3,0	36 - 4	9	7,7
3NKV AD 10/10	3x400 V	3x4	3x5,5	3x7,6	T/T 5,5	36 - 4	10	8,5
3NKV AD 10/12	3x400 V	3x4	3x5,5	3x7,6	T/T 5,5	36 - 4	12	10
3NKV AD 10/14	3x400 V	3x5,5	3x7,5	3x11	T/T 5,5	36 - 4	14	12

MODEL	A	B	A1	C	H1	H2	H max	DNA	DNM	PACKING DIMENSIONS			VOLUME m ³	WEIGHT kg
										L/A	L/B	H		
3NKV AD 10/3	1200	850	1300	400	180	950	1100	DN80	DN80	1400	1800	2000	5,2	385
3NKV AD 10/4	1200	850	1300	400	180	950	1100	DN80	DN80	1400	1800	2000	5,2	400
3NKV AD 10/5	1200	850	1300	400	180	950	1100	DN80	DN80	1400	1800	2000	5,2	412
3NKV AD 10/6	1200	850	1300	400	180	950	1100	DN80	DN80	1400	1800	2000	5,2	415
3NKV AD 10/7	1200	850	1300	400	180	950	1100	DN80	DN80	1400	1800	2000	5,2	445
3NKV AD 10/8	1200	850	1300	400	180	950	1100	DN80	DN80	1400	1800	2000	5,2	448
3NKV AD 10/9	1200	850	1300	400	180	950	1100	DN80	DN80	1400	1800	2000	5,2	452
3NKV AD 10/10	1200	850	1300	400	180	950	1150	DN80	DN80	1400	1800	2000	5,2	481
3NKV AD 10/12	1200	850	1300	400	180	950	1260	DN80	DN80	1400	1800	2000	5,2	485
3NKV AD 10/14	1200	850	1300	400	180	950	1455	DN80	DN80	1400	1800	2000	5,2	571

The sets are supplied in a sturdy cardboard packaging on wooden pallet and installation / maintenance manual.

3 NKV AD 15 - RESIDENTIAL CONSTANT PRESSURE BOOSTER SETS

Pumped liquid temperature range: from 0 °C to +50 °C - Maximum ambient temperature: +40 °C - Max flow rate: 45 m³/h

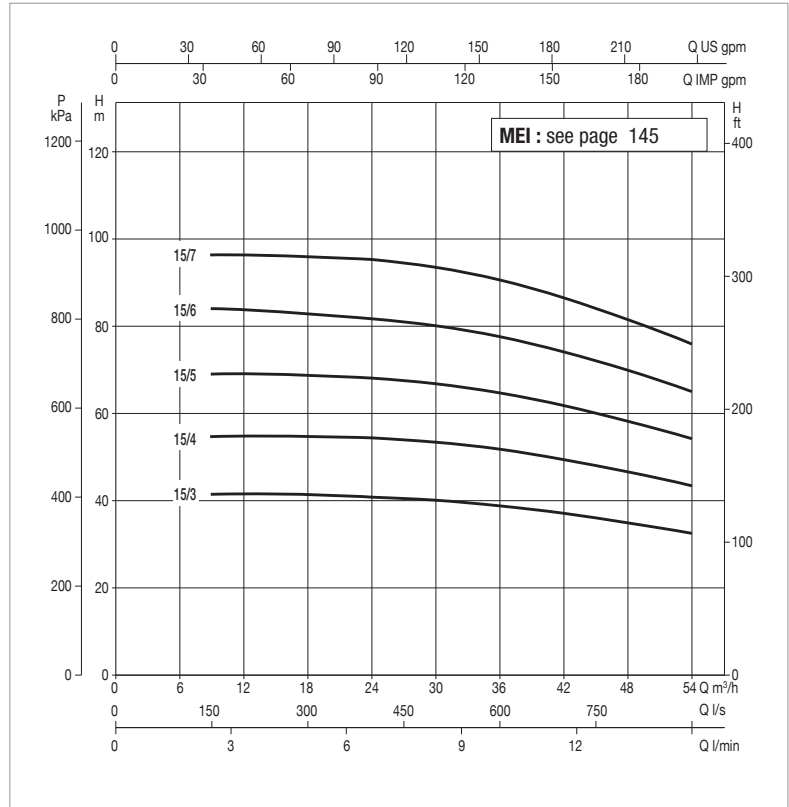
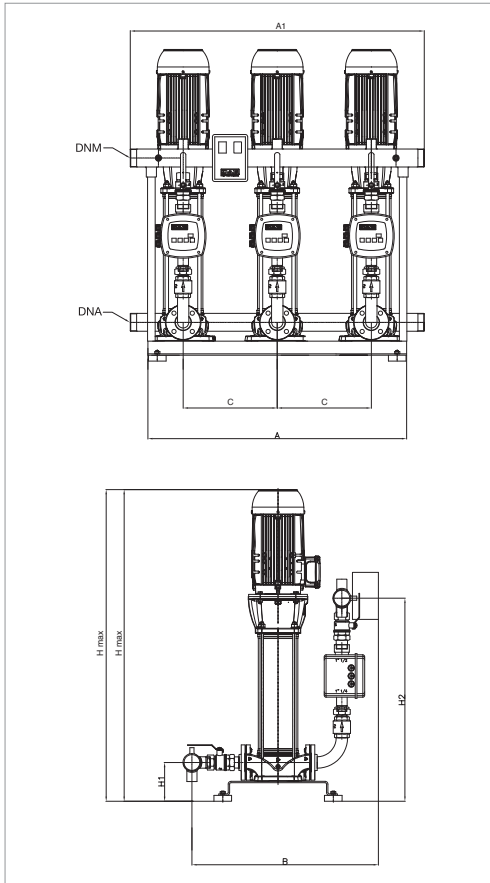

The performance curves are based on kinematic viscosity values = 1 mm²/s and density equal to 1000 kg/m³.
Curve tolerance according to ISO 9906.
Overall performance taking into account THREE pumps working at the same time.

MODEL	POWER INPUT 50 Hz	P2 NOMINAL		In A	ACTIVE DRIVER PLUS MODEL	FLOW m ³ /h	MAX OBTAINABLE PRESSURE BAR	STANDARD PRESSURE BAR
		kW	HP					
3NKV AD 15/3	3x400 V	3x3	3x4	3x5,8	T/T 3,0	45 - 8	4	3,5
3NKV AD 15/4	3x400 V	3x4	3x5,5	3x7,6	T/T 5,5	45 - 8	5	4
3NKV AD 15/5	3x400 V	3x4	3x5,5	3x7,6	T/T 5,5	45 - 8	6,5	5
3NKV AD 15/6	3x400 V	3x5,5	3x7,5	3x11	T/T 5,5	45 - 8	7,5	6,5
3NKV AD 15/7	3x400 V	3x5,5	3x7,5	3x11	T/T 5,5	45 - 8	9	8

MODEL	A	B	A1	C	H1	H2	H max	DNA	DNM	PACKING DIMENSIONS			VOLUME m ³	WEIGHT kg
										L/A	L/B	H		
3NKV AD 15/3	1200	850	1300	400	190	1000	1165	DN125	DN100	1400	1800	2000	5,2	545
3NKV AD 15/4	1200	850	1300	400	190	1000	1165	DN125	DN100	1400	1800	2000	5,2	575
3NKV AD 15/5	1200	850	1300	400	190	1000	1165	DN125	DN100	1400	1800	2000	5,2	578
3NKV AD 15/6	1200	850	1300	400	190	1000	1325	DN125	DN100	1400	1800	2000	5,2	662
3NKV AD 15/7	1200	850	1300	400	190	1000	1360	DN125	DN100	1400	1800	2000	5,2	668

The sets are supplied in a sturdy cardboard packaging on wooden pallet and installation / maintenance manual.

2/3/4 NKVE 10 - 15 - 20 - 32 - 45 MCE/P

CONSTANT PRESSURE SETS WITH MCE/P MULTI INVERTER SYSTEM ON THE PUMP



TECHNICAL DATA

Line voltage: 400V three phase
Voltage of electric pump: 400V three phase
Power frequency: 50-60 Hz
Installation: vertical only
Operating range: from 4 to 280 m³/h
Pumped liquid temperature range: from 0 °C to 80 °C
Maximum ambient temperature: 40°C
Max pressure: 14bar
Pumped liquid: clean, free from solids.
Pressure regulation range: 3 to 14 bar.
Protection class: IP55

APPLICATIONS

The sets with on-board inverter have been designed and manufactured to meet the constant pressure requirements of modern system engineering solutions. The constant pressure adjustment is a requirement in the most varied sectors: Water pipelines, Irrigation, Industry, Hotel, Residential building, Spas. The fundamental concept that has driven our Engineers in developing these pumps sets, was to offer a simple to use, flexible, and extremely reliable product. Differently from traditional fixed speed pumps, inverter driven pumps give the possibility to adapt the performance curve to the needs of the system. In the most classic case, inverter driven pumps are used to maintain constant pressure in the system against variations in the requested flow rate, avoiding pressure fluctuations caused by small flow rate variations.

ADVANTAGES OF USE

Operating pressure stability – Excellent energy savings (up to 60 %) – Reduced hammering effects – Reduced space requirements – Less maintenance – Reduced pump wear – Less power factor correction required – Less water consumption – Integrated protections.

CONSTRUCTION FEATURES

The sets with MCE/P inverters are built in the standard version with two, three, or four centrifugal electric pumps, completely assembled on galvanised steel base, tested and ready (one 18 liters expansion tank for each pump) for installation. Complete with isolator and check valves for each pump, suction and delivery manifolds, expansion vessels, pressure sensor, on-pump inverter, protection control unit. (possibility of optional flow sensor for pressure control).

MULTI INVERTER SYSTEM WITH ON-PUMP MCE/

The inverter continuously adjusts the rotation speed of the electric pump, keeping the pressure constant, even when the flow rate varies.

The other electric pumps, also with variable speed, are activated in cascade after the first one has reached maximum speed. Through modulation, they compensate the pressure fluctuations of the system.

For every operating cycle, it is possible to switch the restart to a different pump, therefore ensuring even use of all electric pumps.

It is possible to set operation times for each individual pump, switching to another pump after such set times.

The "SP" pressure can be adjusted by the user using the "+" and "-" keys found on the MCE/P (as a rule, all the pumps are set to the same pressure value). With the new MCE/P, it is sufficient to set the data on one of the devices, and it will be automatically propagated to the other pumps of the system.

ELECTRIC COMPONENTS SUPPLIED

MCE/P inverter with the following features:

- Abnormal voltage protection.
- Adjustable amperometric protection.
- Dry run protection (without minimum manometer).
- Output phases short circuit protection.
- Overtemperature and overvoltage protection.
- Anti-seizing and anti-freeze functions.
- Pressure sensor fault.
- Thermal magnetic protection control unit (simplified connection).
- Pressure sensor on the delivery manifold.

2 NKVE 10 -MCE/P - CONSTANT PRESSURE BOOSTER SETS

Pumped liquid temperature range: from -15 °C to +80 °C - Maximum ambient temperature: +40 °C - Max flow rate: 26 m³/h

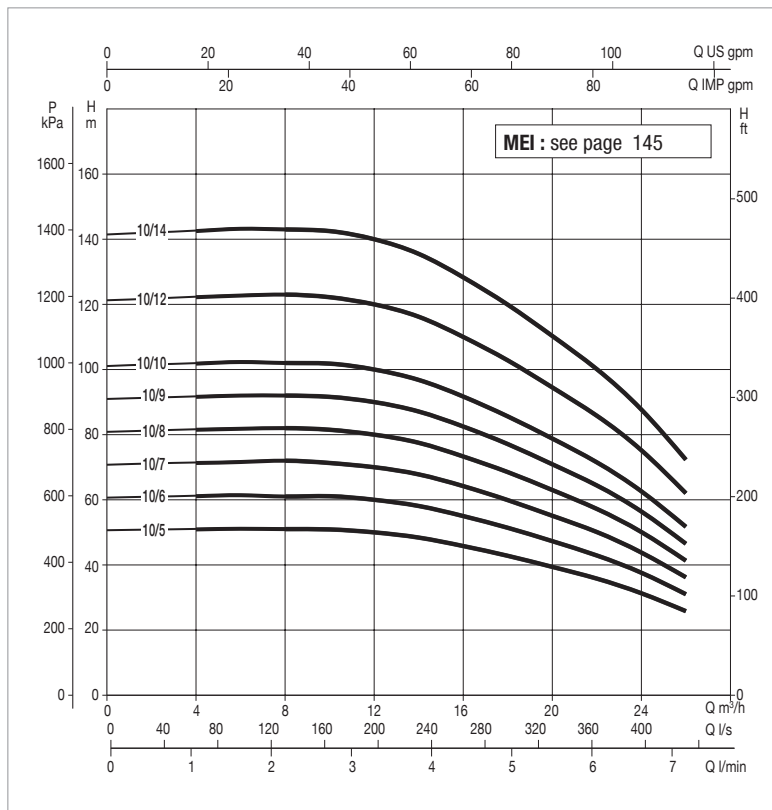
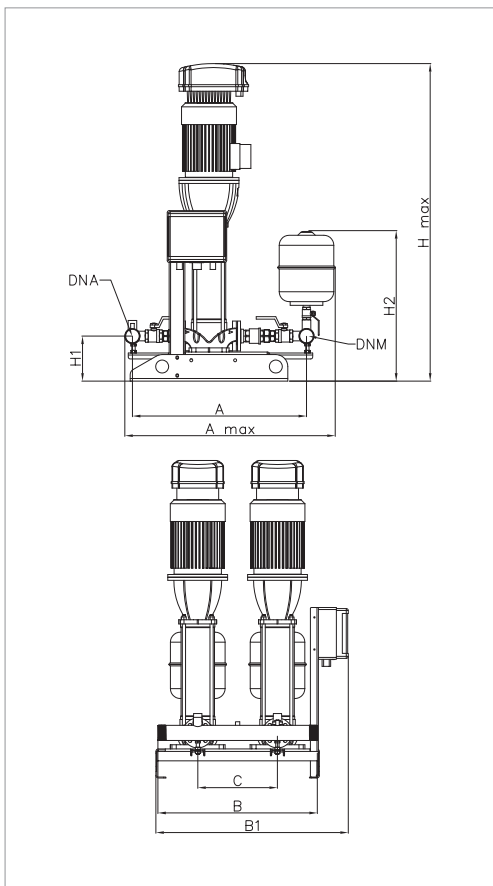

The performance curves are based on kinematic viscosity values = 1 mm²/s and density equal to 1000 kg/m³.
Curve tolerance according to ISO 9906.

Overall performance taking into account TWO pumps working at the same time.

MODEL	PUMP+INVERTER POWER INPUT	P2 NOMINAL		In A	MCE/P MODEL	MAXIMUM FLOW RATE m ³ /h	MAX OBTAINABLE PRESSURE BAR	STANDARD PRESSURE BAR
		KW	HP					
2 NKVE 10/5 T MCE30/P	3 x 400V 50Hz	2x2.2	2x3	2x4.9	MCE30/P	26	5	4,0
2 NKVE 10/6 T MCE30/P	3 x 400V 50Hz	2x2.2	2x3	2x5.4	MCE30/P	26	6	5.0
2 NKVE 10/7 T MCE30/P	3 x 400V 50Hz	2x3	2x4	2x7.37	MCE30/P	26	7	6
2 NKVE 10/8 T MCE30/P	3 x 400V 50Hz	2x3	2x4	2x7.37	MCE30/P	26	8	6.5
2 NKVE 10/9 T MCE30/P	3 x 400V 50Hz	2x3	2x4	2x7.37	MCE30/P	26	9	7.7
2 NKVE 10/10 T MCE30/P	3 x 400V 50Hz	2x4	2x5.5	2x10.1	MCE30/P	26	10	8.5
2 NKVE 10/12 T MCE55/P	3 x 400V 50Hz	2x4	2x5.5	2x10.1	MCE55/P	26	12	10
2 NKVE 10/14 T MCE55/P	3 x 400V 50Hz	2x5.5	2x7.5	2x13.1	MCE55/P	26	14	10

MODEL	A	A MAX	B	B1	C	H1	H2	H MAX	DNA	DNM	PACKING DIMENSIONS			WEIGHT kg
											L/A	L/B	H	
2 NKVE 10/5 T MCE30/P	875	1060	800	965	400	226	755	1109	2" 1/2	2" 1/2	2150	1000	1400	186
2 NKVE 10/6 T MCE30/P	875	1060	800	965	400	226	755	1142	2" 1/2	2" 1/2	2150	1000	1400	187
2 NKVE 10/7 T MCE30/P	875	1060	800	965	400	226	755	1221	2" 1/2	2" 1/2	2150	1000	1400	214
2 NKVE 10/8 T MCE30/P	875	1060	800	965	400	226	755	1254	2" 1/2	2" 1/2	2150	1000	1400	216
2 NKVE 10/9 T MCE30/P	875	1060	800	965	400	226	755	1287	2" 1/2	2" 1/2	2150	1000	1400	218
2 NKVE 10/10 T MCE55/P	875	1060	800	965	400	226	755	1335	2" 1/2	2" 1/2	2150	1000	1400	237
2 NKVE 10/12 T MCE55/P	875	1060	800	965	400	226	755	1401	2" 1/2	2" 1/2	2150	1000	1400	240
2 NKVE 10/14 T MCE55/P	875	1060	800	965	400	226	755	1597	2" 1/2	2" 1/2	2150	1000	1400	298

2 NKVE 15 - MCE/P - CONSTANT PRESSURE BOOSTER SETS

Pumped liquid temperature range: from -15 °C to +80 °C - Maximum ambient temperature: +40 °C - Max flow rate: 48 m³/h

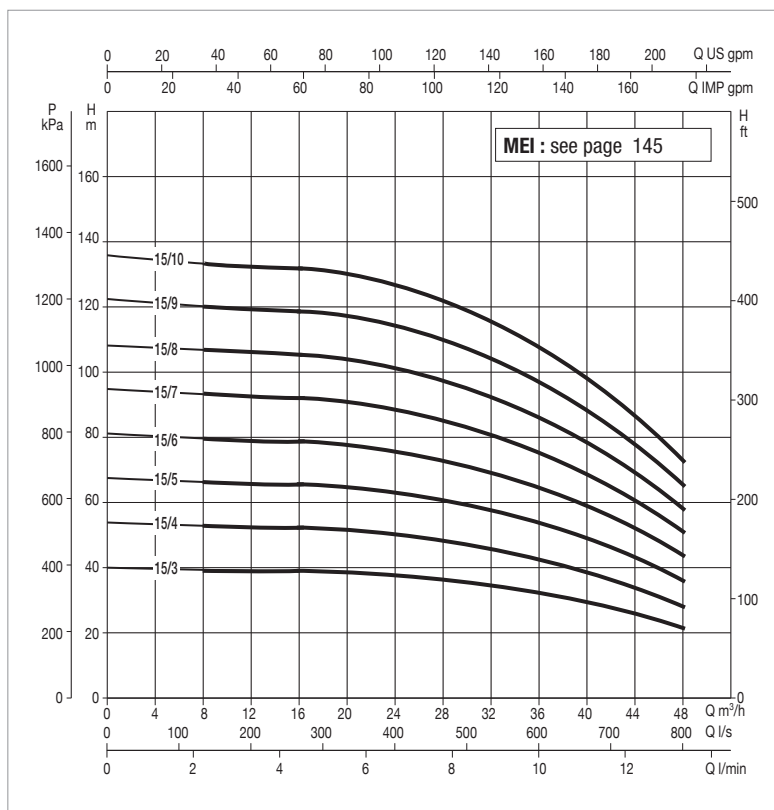
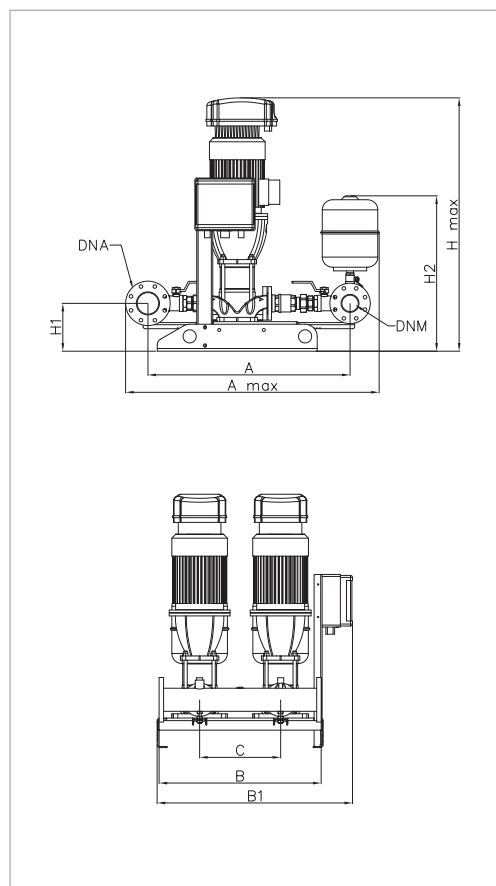

The performance curves are based on kinematic viscosity values = 1 mm²/s and density equal to 1000 kg/m³.
Curve tolerance according to ISO 9906.

Overall performance taking into account TWO pumps working at the same time.

MODEL	PUMP+INVERTER POWER INPUT	P2 NOMINAL		In A	MCE/P MODEL	MAXIMUM FLOW RATE m ³ /h	MAX OBTAINABLE PRESSURE BAR	STANDARD PRESSURE BAR
		KW	HP					
2 NKVE 15/3 T MCE30/P	3 x 400V 50Hz	2x3	2x4	2x7.37	MCE30/P	48	4	3.5
2 NKVE 15/4 T MCE30/P	3 x 400V 50Hz	2x4	2x5.5	2x10.1	MCE30/P	48	5	4
2 NKVE 15/5 T MCE55/P	3 x 400V 50Hz	2x4	2x5.5	2x10.1	MCE55/P	48	6.5	5
2 NKVE 15/6 T MCE55/P	3 x 400V 50Hz	2x5.5	2x7.5	13,1	MCE55/P	48	7.5	6.5
2 NKVE 15/7 T MCE55/P	3 x 400V 50Hz	2x5.5	2x7.5	2x13.1	MCE55/P	48	9	8
2 NKVE 15/8 T MCE55/P	3 x 400V 50Hz	2x7.5	2x10	2x17.6	MCE55/P	48	11	10
2 NKVE 15/9 T MCE55/P	3 x 400V 50Hz	2x7.5	2x10	2x17.6	MCE55/P	48	12	11
2 NKVE 15/10 T MCE110/P	3 x 400V 50Hz	2x11	2x15	2x25.5	MCE110/P	48	13	12

MODEL	A	A MAX	B	B1	C	H1	H2	H MAX	DNA	DNM	PACKING DIMENSIONS			WEIGHT kg
											L/A	L/B	H	
2 NKVE 15/3 T MCE30/P	1000	1255	800	965	400	236	770	1160	100	80	2150	1000	1400	238
2 NKVE 15/4 T MCE30/P	1000	1255	800	965	400	236	770	1225	100	80	2150	1000	1400	258
2 NKVE 15/5 T MCE55/P	1000	1255	800	965	400	236	770	1274	100	80	2150	1000	1400	261
2 NKVE 15/6 T MCE55/P	1000	1255	800	965	400	236	770	1453	100	80	2150	1000	1400	317
2 NKVE 15/7 T MCE55/P	1000	1255	800	965	400	236	770	1503	100	80	2150	1000	1400	319
2 NKVE 15/8 T MCE55/P	1000	1255	800	965	400	236	770	1602	100	80	2150	1000	1400	344
2 NKVE 15/9 T MCE55/P	1000	1255	800	965	400	236	770	1652	100	80	2150	1000	1400	347
2 NKVE 15/10 T MCE110/P	1000	1255	800	965	400	236	770	1846	100	80	2150	1000	1400	459

2 NKVE 20 -MCE/P - CONSTANT PRESSURE BOOSTER SETS

Pumped liquid temperature range: from -15 °C to +80 °C - Maximum ambient temperature: +40 °C - Max flow rate: 58 m³/h

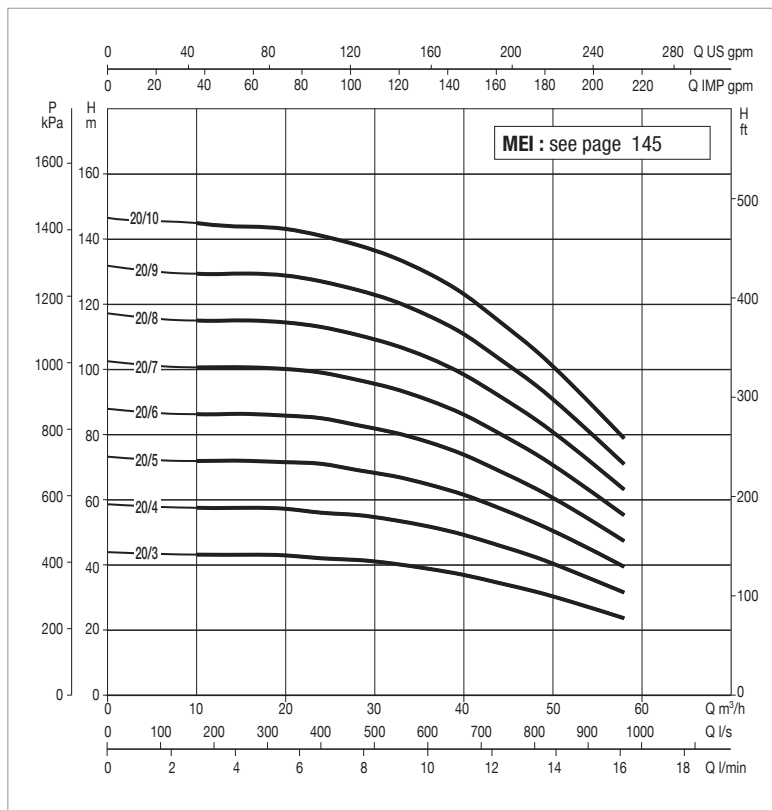
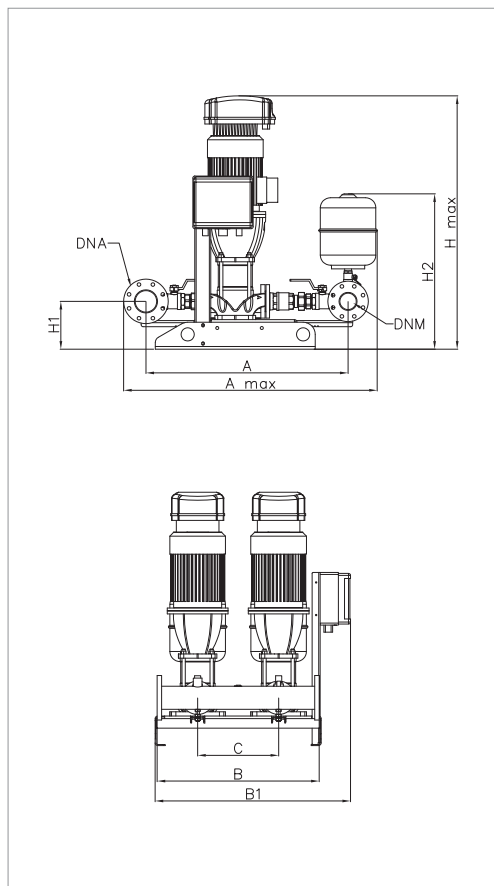

The performance curves are based on kinematic viscosity values = 1 mm²/s and density equal to 1000 kg/m³.
Curve tolerance according to ISO 9906.

Overall performance taking into account TWO pumps working at the same time.

MODEL	PUMP+INVERTER POWER INPUT	P2 NOMINAL		In A	MCE/P MODEL	MAXIMUM FLOW RATE m ³ /h	MAX OBTAINABLE PRESSURE BAR	STANDARD PRESSURE BAR
		KW	HP					
2 NKVE 20/3 T MCE30/P	3 x 400V 50Hz	2x4	2x5.5	2x10.1	MCE30/P	58	4	3.5
2 NKVE 20/4 T MCE55/P	3 x 400V 50Hz	2x5.5	2x7.5	2x13.1	MCE55/P	58	6	5
2 NKVE 20/5 T MCE55/P	3 x 400V 50Hz	2x5.5	2x7.5	2x13.1	MCE55/P	58	7	6
2 NKVE 20/6 T MCE55/P	3 x 400V 50Hz	2x7.5	2x10	2x17.6	MCE55/P	58	8.5	7.5
2 NKVE 20/7 T MCE55/P	3 x 400V 50Hz	2x7.5	2x10	2x17.6	MCE55/P	58	10	9
2 NKVE 20/8 T MCE110/P	3 x 400V 50Hz	2x11	2x15	2x25.5	MCE110/P	58	11.5	10
2 NKVE 20/9 T MCE110/P	3 x 400V 50Hz	2x11	2x15	2x25.5	MCE110/P	58	13	12
2 NKVE 20/10 T MCE110/P	3 x 400V 50Hz	2x11	2x15	2x25.5	MCE110/P	58	14	13

MODEL	A	A MAX	B	B1	C	H1	H2	H MAX	DNA	DNM	PACKING DIMENSIONS			WEIGHT kg
											L/A	L/B	H	
2 NKVE 20/3 T MCE30/P	1000	1255	800	965	400	236	770	1175	100	80	2150	1000	1400	228
2 NKVE 20/4 T MCE55/P	1000	1255	800	965	400	236	770	1354	100	80	2150	1000	1400	256
2 NKVE 20/5 T MCE55/P	1000	1255	800	965	400	236	770	1404	100	80	2150	1000	1400	260
2 NKVE 20/6 T MCE55/P	1000	1255	800	965	400	236	770	1503	100	80	2150	1000	1400	284
2 NKVE 20/7 T MCE55/P	1000	1255	800	965	400	236	770	1553	100	80	2150	1000	1400	286
2 NKVE 20/8 T MCE110/P	1000	1255	800	965	400	236	770	1747	100	80	2150	1000	1400	350
2 NKVE 20/9 T MCE110/P	1000	1255	800	965	400	236	770	1796	100	80	2150	1000	1400	352
2 NKVE 20/10 T MCE110/P	1000	1255	800	965	400	236	770	1846	100	80	2150	1000	1400	374

2 NKVE 32 -MCE/P - CONSTANT PRESSURE BOOSTER SETS

Pumped liquid temperature range: from -15 °C to +80 °C - Maximum ambient temperature: +40 °C - Max flow rate: 90 m³/h

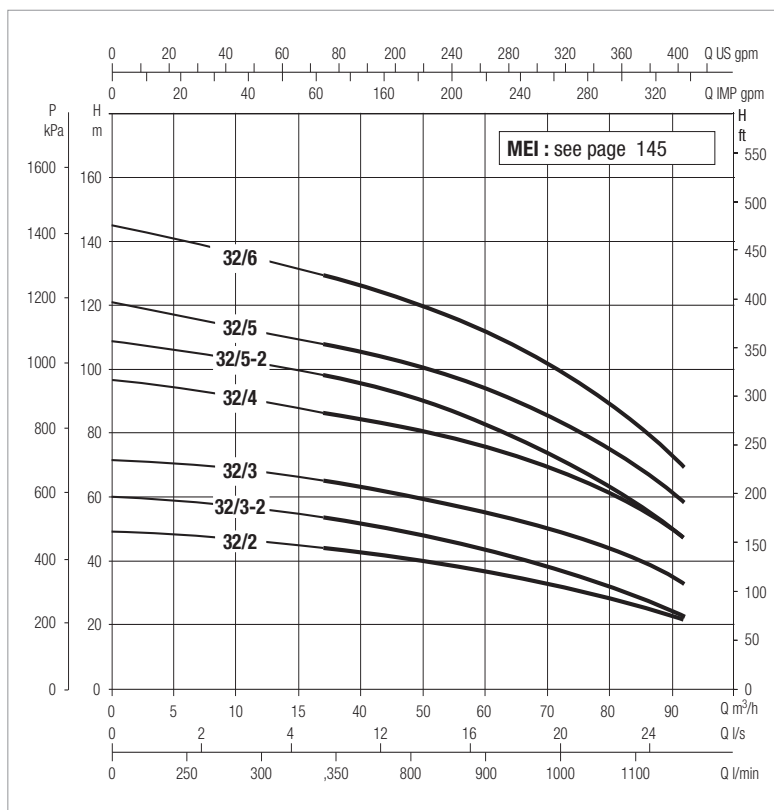
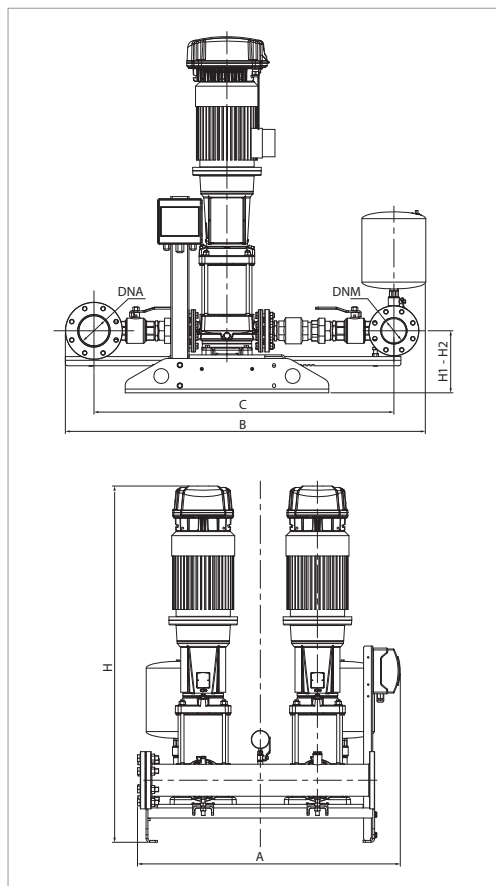

The performance curves are based on kinematic viscosity values = 1 mm²/s and density equal to 1000 kg/m³.
Curve tolerance according to ISO 9906.

Overall performance taking into account TWO pumps working at the same time.

MODEL	PUMP+INVERTER POWER INPUT	P2 NOMINAL		In A	MCE/P MODEL	MAXIMUM FLOW RATE m ³ /h	MAX OBTAINABLE PRESSURE BAR	STANDARD PRESSURE BAR
		KW	HP					
2 NKVE 32/2 T MCE 400-50	3x400 50-60Hz	2x5,5	2x7,5	2x13,1	MCE55/P	90	4,8	4
2 NKVE 32/3-2 T MCE 400-50	3x400 50-60Hz	2x5,5	2x7,5	2x13,1	MCE55/P	90	6,0	5
2 NKVE 32/3 T MCE 400-50	3x400 50-60Hz	2x7,5	2x10	2x17,6	MCE110/P	90	7,3	6
2 NKVE 32/4 T MCE 400-50	3x400 50-60Hz	2x11	2x15	2x25,5	MCE110/P	90	9,8	8
2 NKVE 32/5-2 T MCE 400-50	3x400 50-60Hz	2x11	2x15	2x25,5	MCE110/P	90	10,9	9
2 NKVE 32/5 T MCE 400-50	3x400 50-60Hz	2x15	2x20	2x34	MCE150/P	90	12,2	10
2 NKVE 32/6 T MCE 400-50	3x400 50-60Hz	2x15	2x20	2x34	MCE150/P	90	14,6	12

MODEL	A	B	C	H	H1	H2	DNA	DNM	PACKING DIMENSIONS			WEIGHT kg
									L/A	L/B	H	
2 NKVE 32/2 T MCE 400-50	1150	1575	1312	1476	271	271	150	125	1400	1800	2200	476
2 NKVE 32/3-2 T MCE 400-50	1150	1575	1312	1558	271	271	150	125	1400	1800	2200	484
2 NKVE 32/3 T MCE 400-50	1150	1575	1312	1558	271	271	150	125	1400	1800	2200	506
2 NKVE 32/4 T MCE 400-50	1150	1575	1312	1829	271	271	150	125	1400	1800	2200	616
2 NKVE 32/5-2 T MCE 400-50	1150	1575	1312	1911	271	271	150	125	1400	1800	2200	624
2 NKVE 32/5 T MCE 400-50	1150	1575	1312	1911	271	271	150	125	1400	1800	2200	652
2 NKVE 32/6 T MCE 400-50	1150	1575	1312	1993	271	271	150	125	1400	1800	2200	660

2 NKVE 45 - MCE/P - CONSTANT PRESSURE BOOSTER SETS

Pumped liquid temperature range: from -15 °C to +80 °C - Maximum ambient temperature: +40 °C - Max flow rate: 140 m³/h

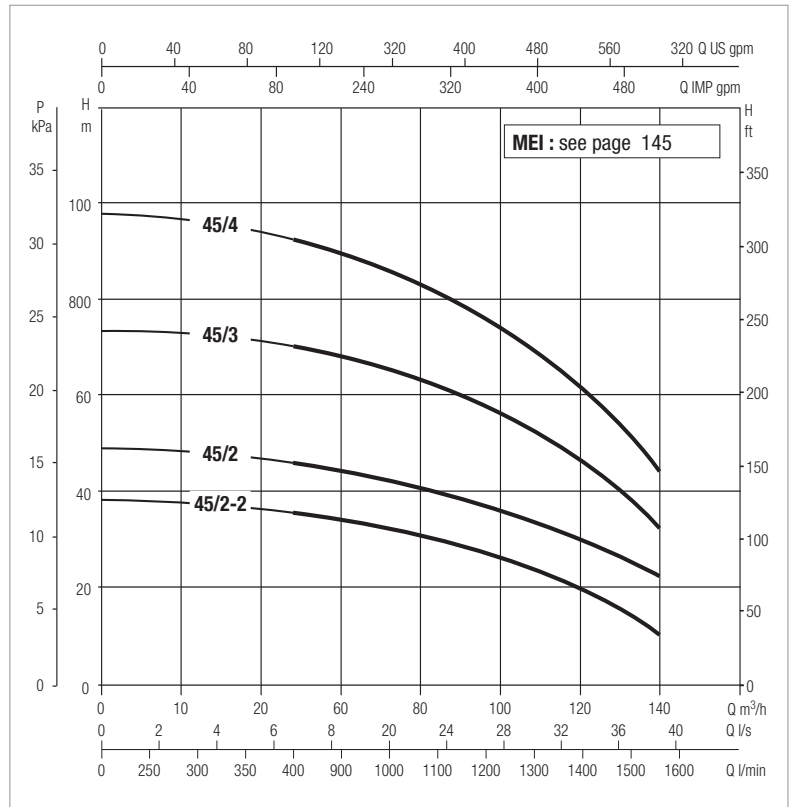
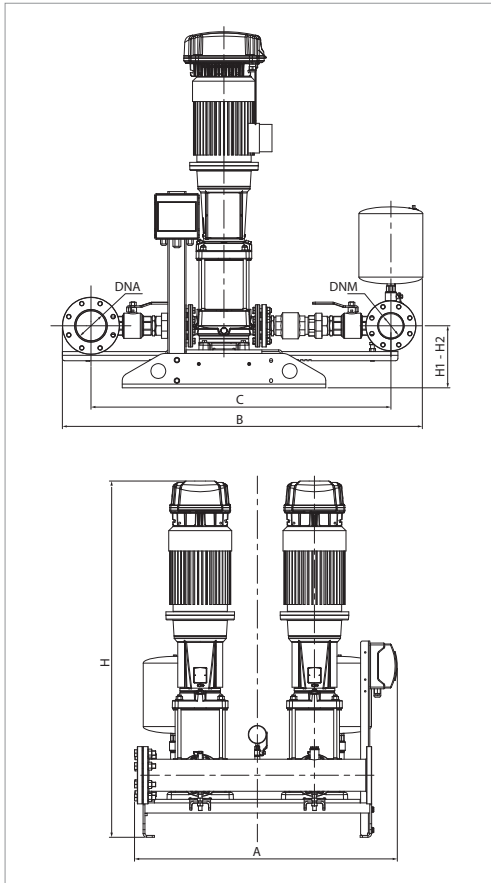

The performance curves are based on kinematic viscosity values = 1 mm²/s and density equal to 1000 kg/m³.
Curve tolerance according to ISO 9906.

Overall performance taking into account TWO pumps working at the same time.

MODEL	PUMP+INVERTER POWER INPUT	P2 NOMINAL		In A	MCE/P MODEL	MAXIMUM FLOW RATE m ³ /h	MAX OBTAINABLE PRESSURE BAR	STANDARD PRESSURE BAR
		KW	HP					
2 NKVE 45/2-2 T MCE 400-50	3x400 50-60Hz	2x5,5	2x7,5	2x13,1	MCE55/P	140	3,8	3
2 NKVE 45/2 T MCE 400-50	3x400 50-60Hz	2x7,5	2x10	2x17,6	MCE110/P	140	4,8	4
2 NKVE 45/3 T MCE 400-50	3x400 50-60Hz	2x11	2x15	2x25,5	MCE110/P	140	7,3	6,5
2 NKVE 45/4 T MCE 400-50	3x400 50-60Hz	2x15	2x20	2x34	MCE150/P	140	9,7	8,5

MODEL	A	B	C	H	H1	H2	DNA	DNM	PACKING DIMENSIONS			WEIGHT kg
									L/A	L/B	H	
2 NKVE 45/2-2 T MCE 400-50	1150	1622	1340	1515	271	271	150	125	1400	1800	2200	488
2 NKVE 45/2 T MCE 400-50	115	1622	1340	1565	271	271	150	125	1400	1800	2200	510
2 NKVE 45/3 T MCE 400-50	1150	1622	1340	1782	271	271	150	125	1400	1800	2200	620
2 NKVE 45/4 T MCE 400-50	1150	1622	1340	1864	271	271	150	125	1400	1800	2200	656

3 NKVE 10 - MCE/P - CONSTANT PRESSURE BOOSTER SETS

Pumped liquid temperature range: from -15 °C to +80 °C - Maximum ambient temperature: +40 °C - Max flow rate: 39 m³/h

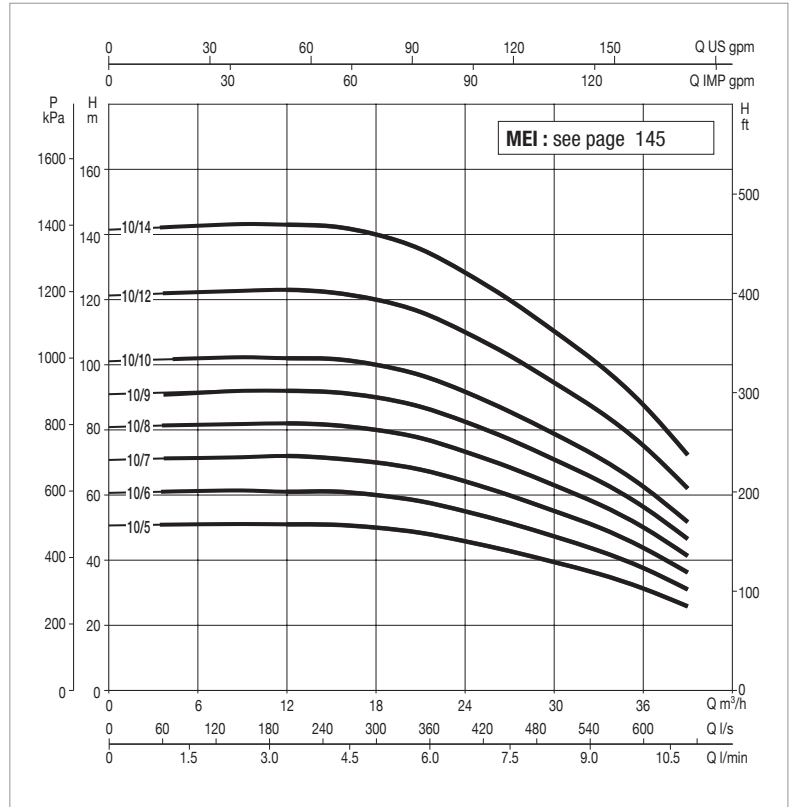
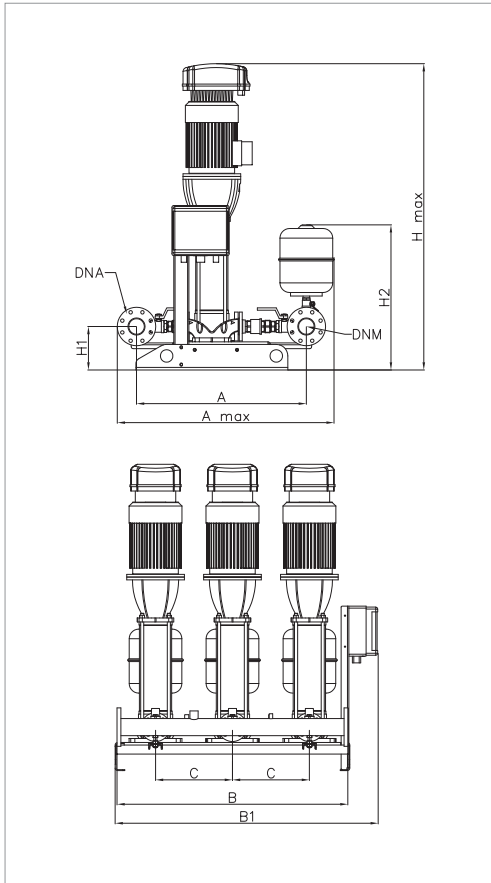

The performance curves are based on kinematic viscosity values = 1 mm²/s and density equal to 1000 kg/m³.
Curve tolerance according to ISO 9906.

Overall performance taking into account THREE pumps working at the same time.

MODEL	PUMP+INVERTER POWER INPUT	P2 NOMINAL		In A	MCE/P MODEL	MAXIMUM FLOW RATE m ³ /h	MAX OBTAINABLE PRESSURE BAR	STANDARD PRESSURE BAR
		KW	HP					
3 NKVE 10/5 T MCE15/P	3 x 400V 50Hz	3x2.2	3x3	3x4.9	MCE15/P	39	5	4.0
3 NKVE 10/6 T MCE15/P	3 x 400V 50Hz	3x2.2	3x3	3x5.4	MCE15/P	39	6	5.0
3 NKVE 10/7 T MCE30/P	3 x 400V 50Hz	3x3	3x4	3x7.37	MCE30/P	39	7	6
3 NKVE 10/8 T MCE30/P	3 x 400V 50Hz	3x3	3x4	3x7.37	MCE30/P	39	8	6.5
3 NKVE 10/9 T MCE30/P	3 x 400V 50Hz	3x3	3x4	3x7.37	MCE30/P	39	9	7.7
3 NKVE 10/10 T MCE30/P	3 x 400V 50Hz	3x4	3x5.5	3x10.1	MCE30/P	39	10	8.5
3 NKVE 10/12 T MCE55/P	3 x 400V 50Hz	3x4	2x5.5	3x10.1	MCE55/P	39	12	10
3 NKVE 10/14 T MCE55/P	3 x 400V 50Hz	3x5.5	3x7.5	3x13.1	MCE55/P	39	14	10

MODEL	A	A MAX	B	B1	C	H1	H2	H MAX	DNA	DNM	PACKING DIMENSIONS			WEIGHT kg
											L/A	L/B	H	
3 NKVE 10/5 T MCE15/P	9.417	1130	1200	1370	400	226	755	1109	80	80	2150	1400	1800	425
3 NKVE 10/6 T MCE15/P	885	1130	1200	1370	400	226	755	1142	80	80	2150	1400	1800	428
3 NKVE 10/7 T MCE30/P	885	1130	1200	1370	400	226	755	1221	80	80	2150	1400	1800	468
3 NKVE 10/8 T MCE30/P	885	1130	1200	1370	400	226	755	1254	80	80	2150	1400	1800	471
3 NKVE 10/9 T MCE30/P	885	1130	1200	1370	400	226	755	1287	80	80	2150	1400	1800	473
3 NKVE 10/10 T MCE30/P	885	1130	1200	1370	400	226	755	1335	80	80	2150	1400	1800	503
3 NKVE 10/12 T MCE55/P	885	1130	1200	1370	400	226	755	1401	80	80	2150	1400	1800	508
3 NKVE 10/14 T MCE55/P	885	1130	1200	1370	400	226	755	1597	80	80	2150	1400	1800	593

3 NKVE 15 - MCE/P - CONSTANT PRESSURE BOOSTER SETS

Pumped liquid temperature range: from -15 °C to +80 °C - Maximum ambient temperature: +40 °C - Max flow rate: 72 m³/h

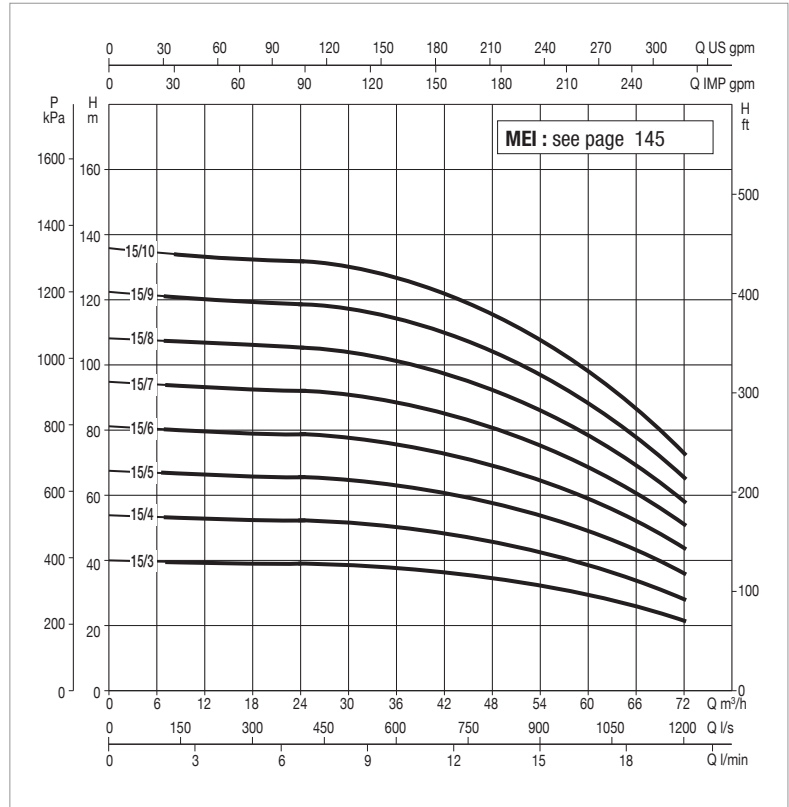
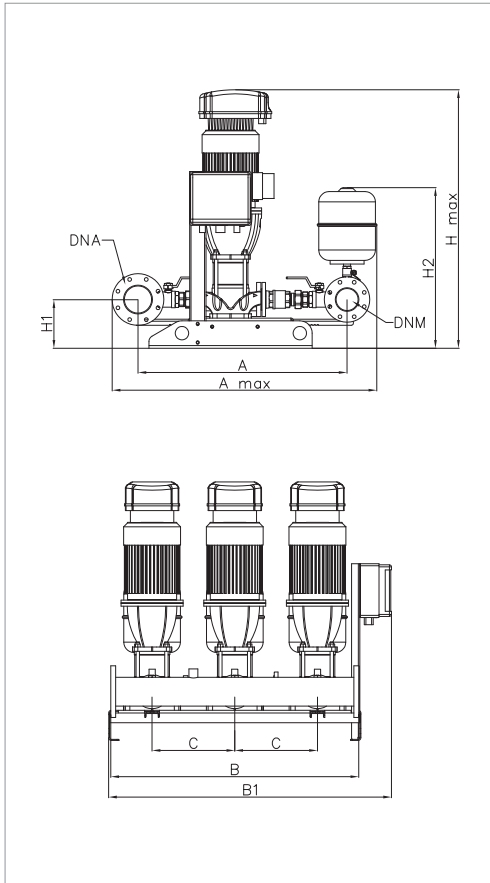

The performance curves are based on kinematic viscosity values = 1 mm²/s and density equal to 1000 kg/m³.
Curve tolerance according to ISO 9906.

Overall performance taking into account THREE pumps working at the same time.

MODEL	PUMP+INVERTER POWER INPUT	P2 NOMINAL		In A	MCE/P MODEL	MAXIMUM FLOW RATE m ³ /h	MAX OBTAINABLE PRESSURE BAR	STANDARD PRESSURE BAR
		KW	HP					
3 NKVE 15/3 T MCE30/P	3 x 400V 50Hz	3x3	3x4	3x7.37	MCE30/P	72	4	3.5
3 NKVE 15/4 T MCE30/P	3 x 400V 50Hz	3x4	3x5.5	3x10.1	MCE30/P	72	5	4
3 NKVE 15/5 T MCE55/P	3 x 400V 50Hz	3x4	3x5.5	3x10.1	MCE55/P	72	6.5	5
3 NKVE 15/6 T MCE55/P	3 x 400V 50Hz	3x5.5	3x7.5	3x13.1	MCE55/P	72	7.5	6.5
3 NKVE 15/7 T MCE55/P	3 x 400V 50Hz	3x5.5	3x7.5	3x13.1	MCE55/P	72	9	8
3 NKVE 15/8 T MCE55/P	3 x 400V 50Hz	3x7.5	3x10	3x17.6	MCE55/P	72	11	10
3 NKVE 15/9 T MCE55/P	3 x 400V 50Hz	3x7.5	3x10	3x17.6	MCE55/P	72	12	11
3 NKVE 15/10 T MCE110/P	3 x 400V 50Hz	3x11	3x15	3x25.5	MCE110/P	72	13	12

MODEL	A	A MAX	B	B1	C	H1	H2	H MAX	DNA	DNM	PACKING DIMENSIONS			WEIGHT kg
											L/A	L/B	H	
3 NKVE 15/3 T MCE30/P	1115	1285	1200	1370	400	236	780	1160	125	100	2150	1400	1800	486
3 NKVE 15/4 T MCE30/P	1115	1285	1200	1370	400	236	780	1225	125	100	2150	1400	1800	516
3 NKVE 15/5 T MCE55/P	1115	1285	1200	1370	400	236	780	1274	125	100	2150	1400	1800	520
3 NKVE 15/6 T MCE55/P	1115	1285	1200	1370	400	236	780	1453	125	100	2150	1400	1800	605
3 NKVE 15/7 T MCE55/P	1115	1285	1200	1370	400	236	780	1503	125	100	2150	1400	1800	608
3 NKVE 15/8 T MCE55/P	1115	1285	1200	1370	400	236	780	1602	125	100	2150	1400	1800	645
3 NKVE 15/9 T MCE55/P	1115	1285	1200	1370	400	236	780	1652	125	100	2150	1400	1800	649
3 NKVE 15/10 T MCE110/P	1115	1285	1200	1370	400	236	780	1846	125	100	2150	1400	1800	818

3 NKVE 20 - MCE/P - CONSTANT PRESSURE BOOSTER SETS

Pumped liquid temperature range: from -15 °C to +80 °C - Maximum ambient temperature: +40 °C - Max flow rate: 87 m³/h

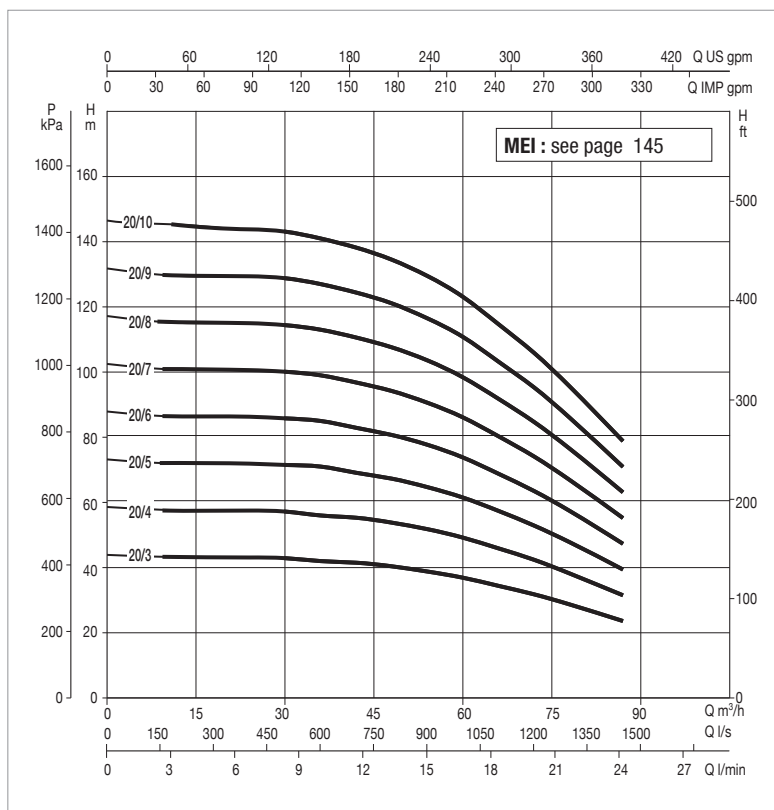
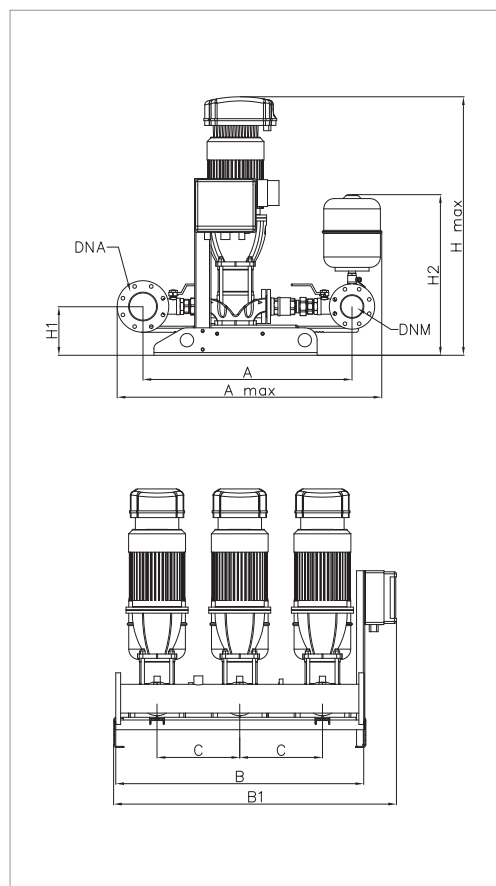

The performance curves are based on kinematic viscosity values = 1 mm²/s and density equal to 1000 kg/m³.
Curve tolerance according to ISO 9906.

Overall performance taking into account THREE pumps working at the same time.

MODEL	PUMP+INVERTER POWER INPUT	P2 NOMINAL		In [A]	MCE/P MODEL	MAXIMUM FLOW RATE m ³ /h	MAX OBTAINABLE PRESSURE BAR	STANDARD PRESSURE BAR
		[KW]	[HP]					
3 NKVE 20/3 T MCE30/P	3 x 400V 50Hz	3x4	3x5.5	3x10.1	MCE30/P	87	4	3.5
3 NKVE 20/4 T MCE55/P	3 x 400V 50Hz	3x5.5	3x7.5	3x13.1	MCE55/P	87	6	5
3 NKVE 20/5 T MCE55/P	3 x 400V 50Hz	3x5.5	3x7.5	3x13.1	MCE55/P	87	7	6
3 NKVE 20/6 T MCE55/P	3 x 400V 50Hz	3x7.5	3x10	3x17.6	MCE55/P	87	8.5	7.5
3 NKVE 20/7 T MCE55/P	3 x 400V 50Hz	3x7.5	3x10	3x17.6	MCE55/P	87	10	9
3 NKVE 20/8 T MCE110/P	3 x 400V 50Hz	3x11	3x15	3x25.5	MCE110/P	87	11.5	10
3 NKVE 20/9 T MCE110/P	3 x 400V 50Hz	3x11	3x15	3x25.5	MCE110/P	87	13	12
3 NKVE 20/10 T MCE110/P	3 x 400V 50Hz	3x11	3x15	3x25.5	MCE110/P	87	14	13

MODEL	A	A MAX	B	B1	C	H1	H2	H MAX	DNA	DNM	PACKING DIMENSIONS			WEIGHT kg
											L/A	L/B	H	
3 NKVE 20/3 T MCE30/P	1115	1285	1200	1370	400	236	780	1175	125	100	2150	1400	1800	471
3 NKVE 20/4 T MCE55/P	1115	1285	1200	1370	400	236	780	1354	125	100	2150	1400	1800	513
3 NKVE 20/5 T MCE55/P	1115	1285	1200	1370	400	236	780	1404	125	100	2150	1400	1800	519
3 NKVE 20/6 T MCE55/P	1115	1285	1200	1370	400	236	780	1503	125	100	2150	1400	1800	556
3 NKVE 20/7 T MCE55/P	1115	1285	1200	1370	400	236	780	1553	125	100	2150	1400	1800	559
3 NKVE 20/8 T MCE110/P	1115	1285	1200	1370	400	236	780	1747	125	100	2150	1400	1800	655
3 NKVE 20/9 T MCE110/P	1115	1285	1200	1370	400	236	780	1796	125	100	2150	1400	1800	658
3 NKVE 20/10 T MCE110/P	1115	1285	1200	1370	400	236	780	1846	125	100	2150	1400	1800	691

3 NKVE 32 -MCE/P - CONSTANT PRESSURE BOOSTER SETS

Pumped liquid temperature range: from -15 °C to +80 °C - Maximum ambient temperature: +40 °C - Max flow rate: 135 m³/h

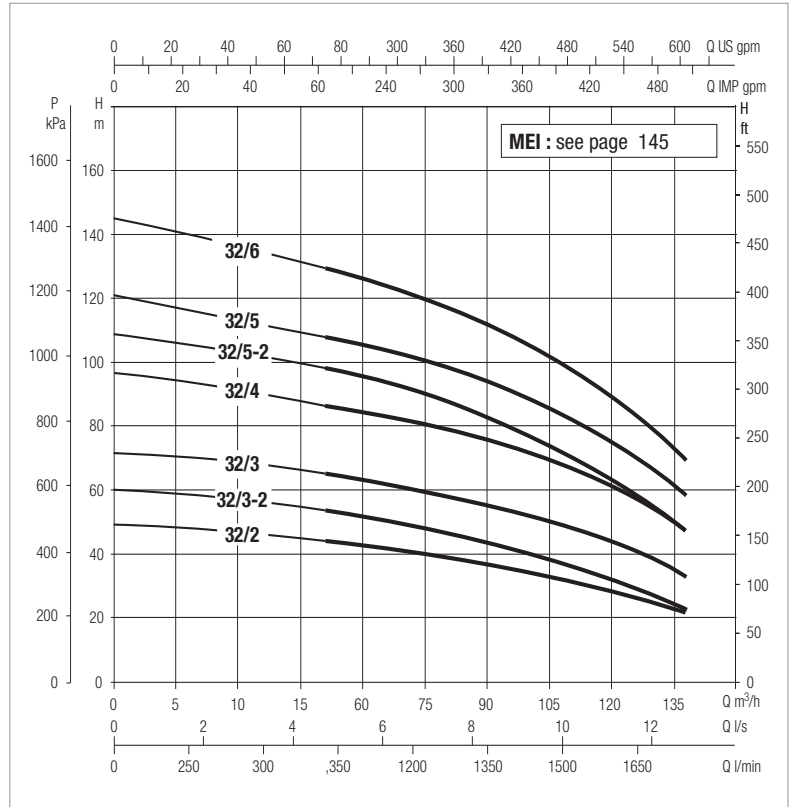
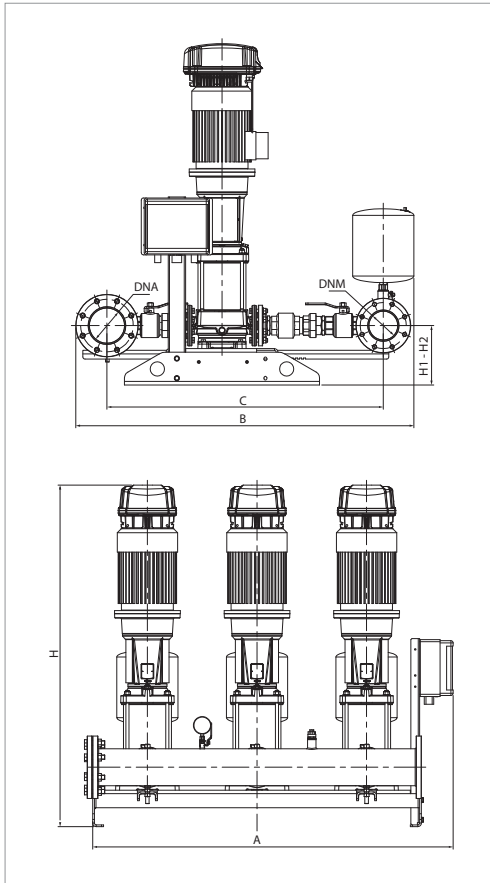

The performance curves are based on kinematic viscosity values = 1 mm²/s and density equal to 1000 kg/m³.
Curve tolerance according to ISO 9906.

Overall performance taking into account THREE pumps working at the same time.

MODEL	PUMP+INVERTER POWER INPUT	P2 NOMINAL		In A	MCE/P MODEL	MAXIMUM FLOW RATE m³/h	MAX OBTAINABLE PRESSURE BAR	STANDARD PRESSURE BAR
		KW	HP					
3 NKVE 32/2 T MCE 400-50	3x400 50-60Hz	2x5,5	2x7,5	2x13,1	MCE55/P	135	4,8	4
3 NKVE 32/3-2 T MCE 400-50	3x400 50-60Hz	2x5,5	2x7,5	2x13,1	MCE55/P	135	6,0	5
3 NKVE 32/3 T MCE 400-50	3 x 400V 50Hz	2x7,5	2x10	2x17,6	MCE110/P	135	7,3	6
3 NKVE 32/4 T MCE 400-50	3 x 400V 50Hz	2x11	2x15	2x25,5	MCE110/P	135	9,8	8
3 NKVE 32/5-2 T MCE 400-50	3 x 400V 50Hz	2x11	2x15	2x25,5	MCE110/P	135	10,9	9
3 NKVE 32/5 T MCE 400-50	3x400 50-60Hz	2x15	2x20	2x34	MCE150/P	135	12,2	10
3 NKVE 32/6 T MCE 400-50	3x400 50-60Hz	2x15	2x20	2x34	MCE150/P	135	14,6	12

MODEL	A	B	C	H	H1	H2	DNA	DNM	PACKING DIMENSIONS			WEIGHT kg
									L/A	L/B	H	
3 NKVE 32/2 T MCE 400-50	1683	1575	1312	1476	271	271	150	125	1500	2250	2200	714
3 NKVE 32/3-2 T MCE 400-50	1683	1575	1312	1558	271	271	150	125	1500	2250	2200	726
3 NKVE 32/3 T MCE 400-50	1683	1575	1312	1558	271	271	150	125	1500	2250	2200	759
3 NKVE 32/4 T MCE 400-50	1683	1575	1312	1829	271	271	150	125	1500	2250	2200	924
3 NKVE 32/5-2 T MCE 400-50	1683	1575	1312	1911	271	271	150	125	1500	2250	2200	936
3 NKVE 32/5 T MCE 400-50	1683	1575	1312	1911	271	271	150	125	1500	2250	2200	978
3 NKVE 32/6 T MCE 400-50	1683	1575	1312	1993	271	271	150	125	1500	2250	2200	990

3 NKVE 45 -MCE/P - CONSTANT PRESSURE BOOSTER SETS

Pumped liquid temperature range: from -15 °C to +80 °C - Maximum ambient temperature: +40 °C - Max flow rate: 210 m³/h

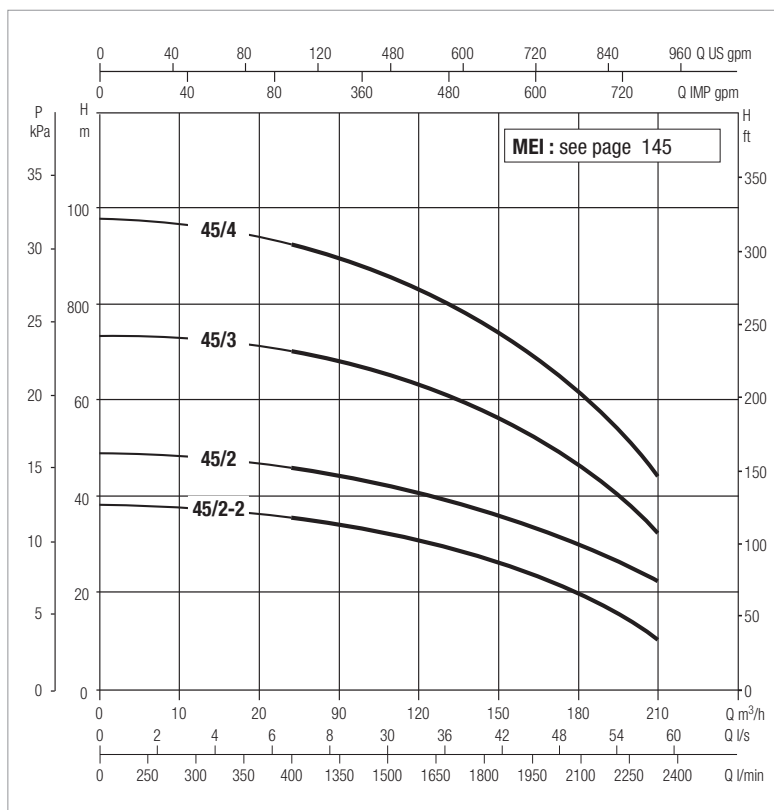
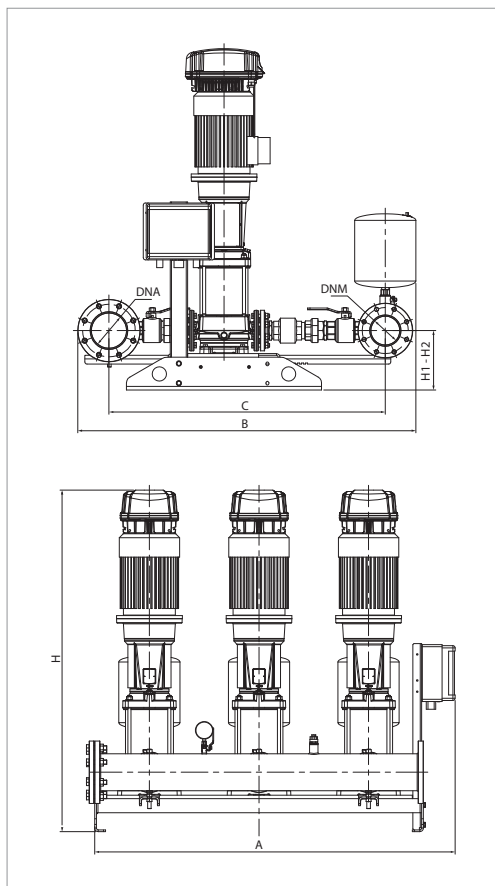

The performance curves are based on kinematic viscosity values = 1 mm²/s and density equal to 1000 kg/m³.
Curve tolerance according to ISO 9906.

Overall performance taking into account THREE pumps working at the same time.

MODEL	PUMP+INVERTER POWER INPUT	P2 NOMINAL		In A	MCE/P MODEL	MAXIMUM FLOW RATE m ³ /h	MAX OBTAINABLE PRESSURE BAR	STANDARD PRESSURE BAR
		kW	HP					
3 NKVE 45/2-2 T MCE 400-50	3x400 50-60Hz	2x5,5	2x7,5	2x13,1	MCE55/P	210	3,8	3
3 NKVE 45/2 T MCE 400-50	3x400 50-60Hz	2x7,5	2x10	2x17,6	MCE110/P	210	4,8	4
3 NKVE 45/3 T MCE 400-50	3 x 400V 50Hz	2x11	2x15	2x25,5	MCE110/P	210	7,3	6,5
3 NKVE 45/4 T MCE 400-50	3x400 50-60Hz	2x15	2x20	2x34	MCE150/P	210	9,7	8,5

MODEL	A	B	C	H	H1	H2	DNA	DNM	PACKING DIMENSIONS			WEIGHT kg
									L/A	L/B	H	
3 NKVE 45/2-2 T MCE 400-50	1683	1622	1340	1515	306	306	200	150	1500	2250	2200	732
3 NKVE 45/2 T MCE 400-50	1683	1622	1340	1565	306	306	200	150	1500	2250	2200	765
3 NKVE 45/3 T MCE 400-50	1683	1622	1340	1782	306	306	200	150	1500	2250	2200	930
3 NKVE 45/4 T MCE 400-50	1683	1622	1340	1864	306	306	200	150	1500	2250	2200	984

4 NKVE 10 -MCE/P - CONSTANT PRESSURE BOOSTER SETS

Pumped liquid temperature range: from -15 °C to +80 °C - Maximum ambient temperature: +40 °C - Max flow rate: 52 m³/h

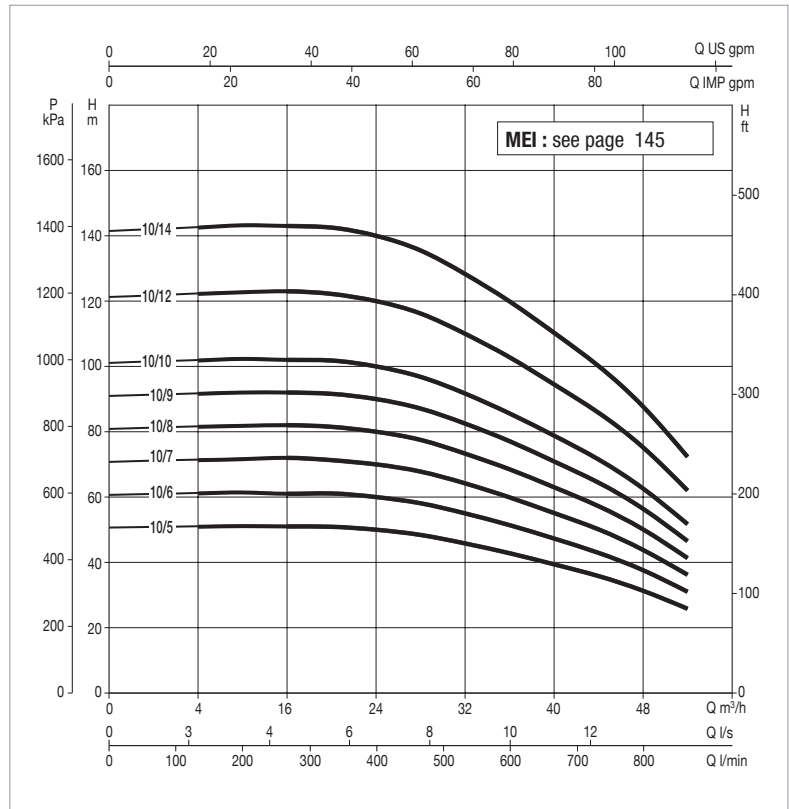
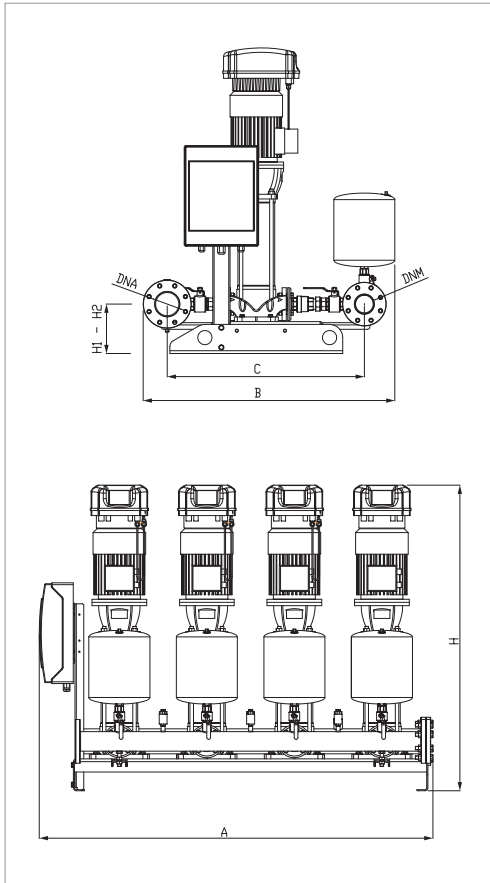

The performance curves are based on kinematic viscosity values = 1 mm²/s and density equal to 1000 kg/m³.
Curve tolerance according to ISO 9906.

Overall performance taking into account FOUR pumps working at the same time.

MODEL	PUMP+INVERTER POWER INPUT	P2 NOMINAL		In A	MCE/P MODEL	MAXIMUM FLOW RATE m ³ /h	MAX OBTAINABLE PRESSURE BAR	STANDARD PRESSURE BAR
		KW	HP					
4NKVE 10/5 T MCE 400-50	3 x 400V 50Hz	4x2.2	4x3	4x4.9	MCE15/P	52	5	4
4NKVE 10/6 T MCE 400-50	3 x 400V 50Hz	4x2.2	4x3	4x5.4	MCE15/P	52	6	5
4NKVE 10/7 T MCE 400-50	3 x 400V 50Hz	4x3	4x4	4x7.37	MCE30/P	52	7	6
4NKVE 10/8 T MCE 400-50	3 x 400V 50Hz	4x3	4x4	4x7.37	MCE30/P	52	8	6.5
4NKVE 10/9 T MCE 400-50	3 x 400V 50Hz	4x3	4x4	4x7.37	MCE30/P	52	9	7.7
4NKVE 10/10 T MCE 400-50	3 x 400V 50Hz	4x4	4x5.5	4x10.1	MCE30/P	52	10	8.5
4NKVE 10/12 T MCE 400-50	3 x 400V 50Hz	4x4	4x5.5	4x10.1	MCE55/P	52	12	10

MODEL	A	B	C	H	H1	H2	H MAX	DNA	DNM	PACKING DIMENSIONS			WEIGHT kg
										L/A	L/B	H	
4 NKVE 10/5 T MCE 400-50	1800	1150	900	1108	226	226	1109	100	80	2250	1500	2200	327
4 NKVE 10/6 T MCE 400-50	1800	1150	900	1141	226	226	1142	100	80	2250	1500	2200	571
4 NKVE 10/7 T MCE 400-50	1800	1150	900	1221	226	226	1221	100	80	2250	1500	2200	624
4 NKVE 10/8 T MCE 400-50	1800	1150	900	1254	226	226	1254	100	80	2250	1500	2200	628
4 NKVE 10/9 T MCE 400-50	1800	1150	900	1287	226	226	1287	100	80	2250	1500	2200	631
4 NKVE 10/10 T MCE 400-50	1800	1150	900	1335	226	226	1335	100	80	2250	1500	2200	671
4 NKVE 10/12 T MCE 400-50	1800	1150	900	1401	226	226	1401	100	80	2250	1500	2200	678

4 NKVE 15 - MCE/P - CONSTANT PRESSURE BOOSTER SETS

Pumped liquid temperature range: from -15 °C to +80 °C - Maximum ambient temperature: +40 °C - Max flow rate: 96 m³/h

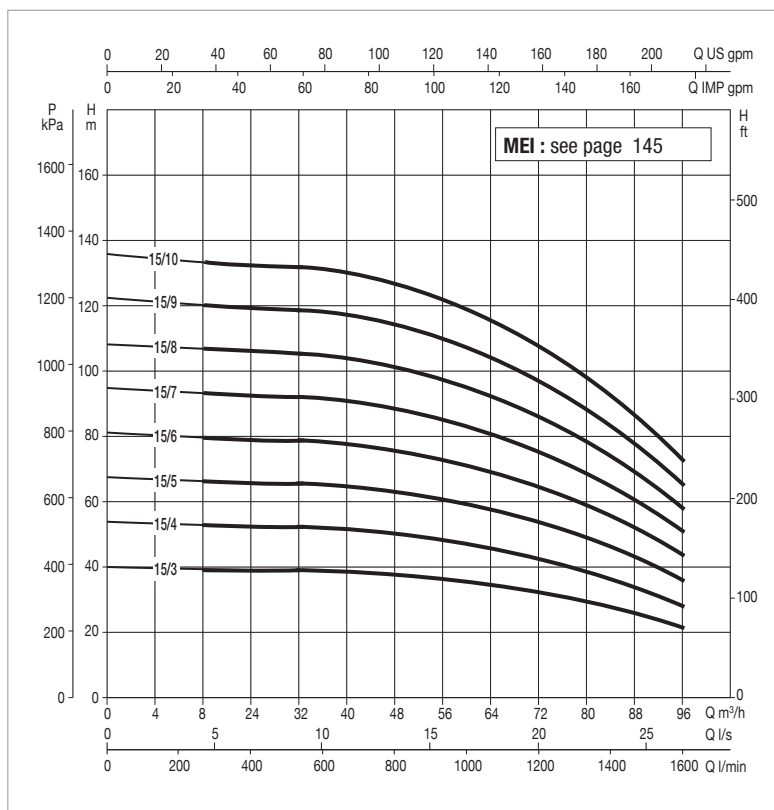
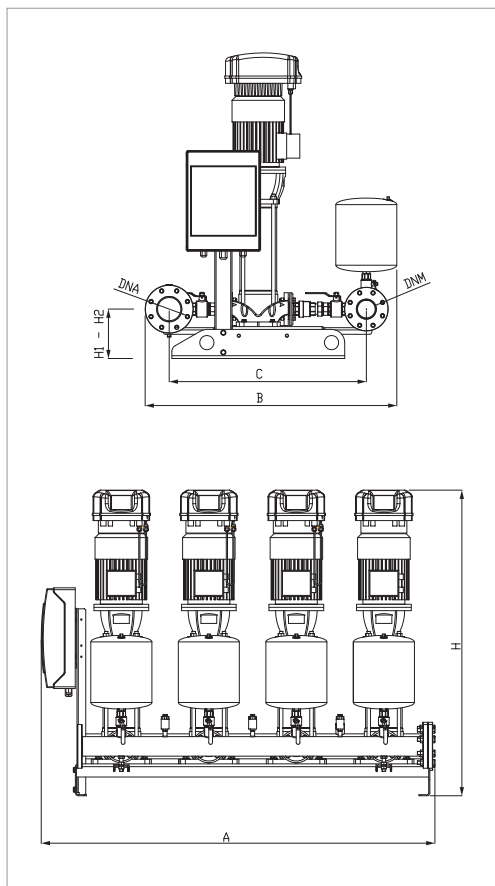

The performance curves are based on kinematic viscosity values = 1 mm²/s and density equal to 1000 kg/m³.
Curve tolerance according to ISO 9906.

Overall performance taking into account FOUR pumps working at the same time.

MODEL	PUMP+INVERTER POWER INPUT	P2 NOMINAL		In A	MCE/P MODEL	MAXIMUM FLOW RATE m ³ /h	MAX OBTAINABLE PRESSURE BAR	STANDARD PRESSURE BAR
		kW	HP					
4NKVE 15/3 T MCE 400-50	3 x 400V 50Hz	4x3	4x4	4x7.37	MCE30/P	96	4	3.5
4NKVE 15/4 T MCE 400-50	3 x 400V 50Hz	4x4	4x5.5	4x10.1	MCE30/P	96	5	4
4NKVE 15/5 T MCE 400-50	3 x 400V 50Hz	4x4	4x5.5	4x10.1	MCE55/P	96	6.5	5
4NKVE 15/6 T MCE 400-50	3 x 400V 50Hz	4x5.5	4x7.5	4x13.1	MCE55/P	96	7.5	6.5
4NKVE 15/7 T MCE 400-50	3 x 400V 50Hz	4x5.5	4x7.5	4x13.1	MCE55/P	96	9	8
4NKVE 15/8 T MCE 400-50	3 x 400V 50Hz	4x7.5	4x10	4x17.6	MCE55/P	96	11	10
4NKVE 15/9 T MCE 400-50	3 x 400V 50Hz	4x7.5	4x10	4x17.6	MCE55/P	96	12	11
4NKVE 15/10 T MCE 400-50	3 x 400V 50Hz	4x11	4x15	4x25.5	MCE110/P	96	13	12

MODEL	A	B	C	H	H1	H2	DNA	DNM	PACKING DIMENSIONS			WEIGHT kg
									L/A	L/B	H	
4 NKVE 15/3 T MCE 400-50	1800	1330	1050	1160	236	236	150	125	2150	1000	1400	648
4 NKVE 15/4 T MCE 400-50	1800	1330	1050	1225	236	236	150	125	2150	1000	1400	688
4 NKVE 15/5 T MCE 400-50	1800	1330	1050	1274	236	236	150	125	2150	1000	1400	694
4 NKVE 15/6 T MCE 400-50	1800	1330	1050	1453	236	236	150	125	2150	1000	1400	807
4 NKVE 15/7 T MCE 400-50	1800	1330	1050	1503	236	236	150	125	2150	1000	1400	811
4 NKVE 15/8 T MCE 400-50	1800	1330	1050	1602	236	236	150	125	2150	1000	1400	860
4 NKVE 15/9 T MCE 400-50	1800	1330	1050	1652	236	236	150	125	2150	1000	1400	865
4 NKVE 15/10 T MCE 400-50	1800	1330	1050	1846	236	236	150	125	2150	1000	1400	919

4 NKVE 20 - MCE/P - CONSTANT PRESSURE BOOSTER SETS

Pumped liquid temperature range: from -15 °C to +80 °C - Maximum ambient temperature: +40 °C - Max flow rate: 116 m³/h

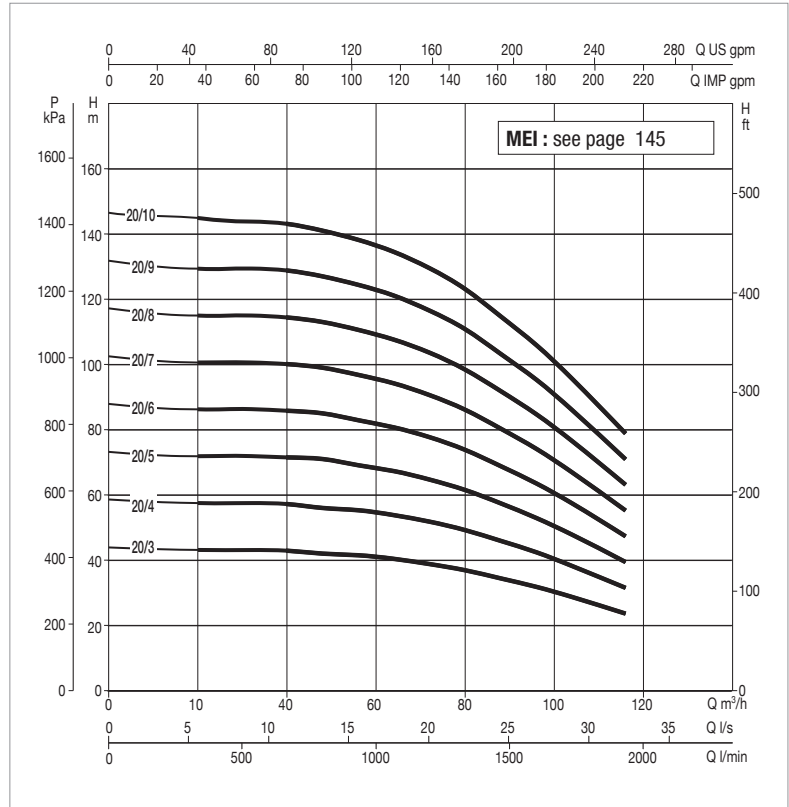
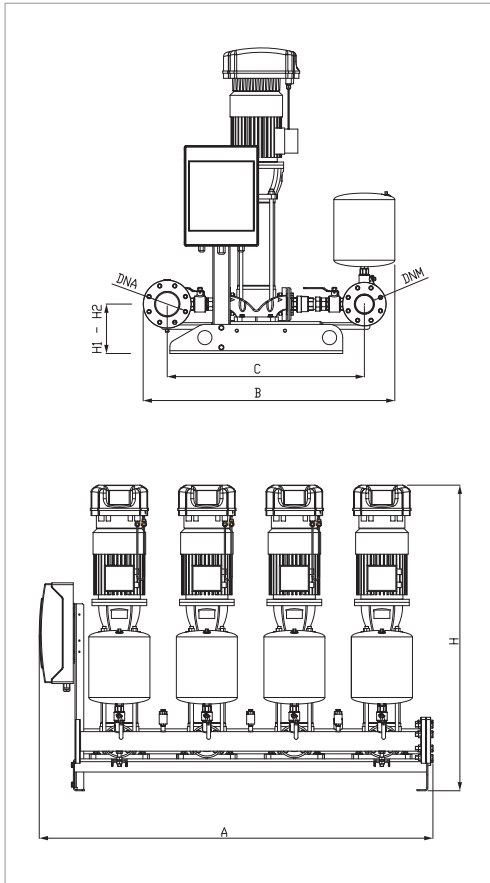

The performance curves are based on kinematic viscosity values = 1 mm²/s and density equal to 1000 kg/m³.
Curve tolerance according to ISO 9906.

Overall performance taking into account FOUR pumps working at the same time.

MODEL	PUMP+INVERTER POWER INPUT	P2 NOMINAL		In A	MCE/P MODEL	MAXIMUM FLOW RATE m ³ /h	MAX OBTAINABLE PRESSURE BAR	STANDARD PRESSURE BAR
		KW	HP					
4NKVE 20/3 T MCE 400-50	3 x 400V 50Hz	4x4	4x5.5	4x10.1	MCE30/P	116	4	3.5
4NKVE 20/4 T MCE 400-50	3 x 400V 50Hz	4x5.5	4x7.5	4x13.1	MCE55/P	116	6	5
4NKV 20/5 T MCE 400-50	3 x 400V 50Hz	4x5.5	4x7.5	4x13.1	MCE55/P	116	7	6
4NKVE 20/6 T MCE 400-50	3 x 400V 50Hz	4x7.5	4x10	4x17.6	MCE55/P	116	8.5	7.5
4NKVE 20/7 T MCE 400-50	3 x 400V 50Hz	4x7.5	4x10	4x17.6	MCE55/P	116	10	9
4NKVE 20/8 T MCE 400-50	3 x 400V 50Hz	4x11	4x15	4x25.5	MCE110/P	116	11.5	10
4NKVE 20/9 T MCE 400-50	3 x 400V 50Hz	4x11	4x15	4x25.5	MCE110/P	116	13	12
4NKVE 20/10 T MCE 400-50	3 x 400V 50Hz	4x11	4x15	4x25.5	MCE110/P	116	14	13

MODEL	A	B	C	H	H1	H2	DNA	DNM	PACKING DIMENSIONS			WEIGHT kg
									L/A	L/B	H	
4 NKVE 20/3 T MCE 400-50	1800	1330	1150	1175	236	236	150	125	2150	1000	1400	628
4 NKVE 20/4 T MCE 400-50	1800	1330	1150	1354	236	236	150	125	2150	1000	1400	684
4 NKVE 20/5 T MCE 400-50	1800	1330	1150	1404	236	236	150	125	2150	1000	1400	692
4 NKVE 20/6 T MCE 400-50	1800	1330	1150	1503	236	236	150	125	2150	1000	1400	741
4 NKVE 20/7 T MCE 400-50	1800	1330	1150	1553	236	236	150	125	2150	1000	1400	745
4 NKVE 20/8 T MCE 400-50	1800	1330	1150	1747	236	236	150	125	2150	1000	1400	873
4 NKVE 20/9 T MCE 400-50	1800	1330	1150	1796	236	236	150	125	2150	1000	1400	877
4 NKVE 20/10 T MCE 400-50	1800	1330	1150	1846	236	236	150	125	2150	1000	1400	921

4 NKVE 32 -MCE/P - CONSTANT PRESSURE BOOSTER SETS

Pumped liquid temperature range: from -15 °C to +80 °C - Maximum ambient temperature: +40 °C - Max flow rate: 180 m³/h

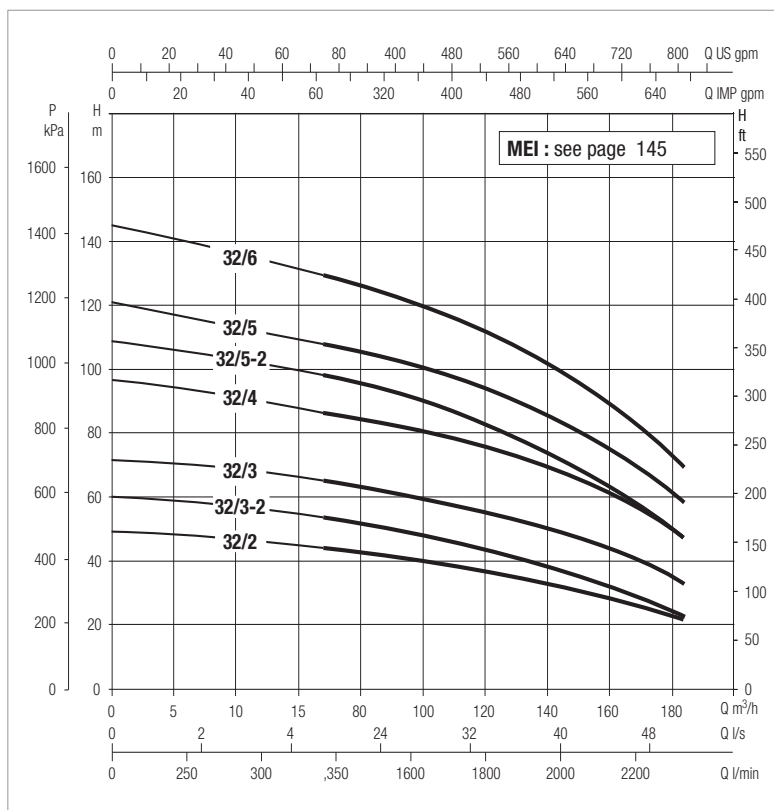
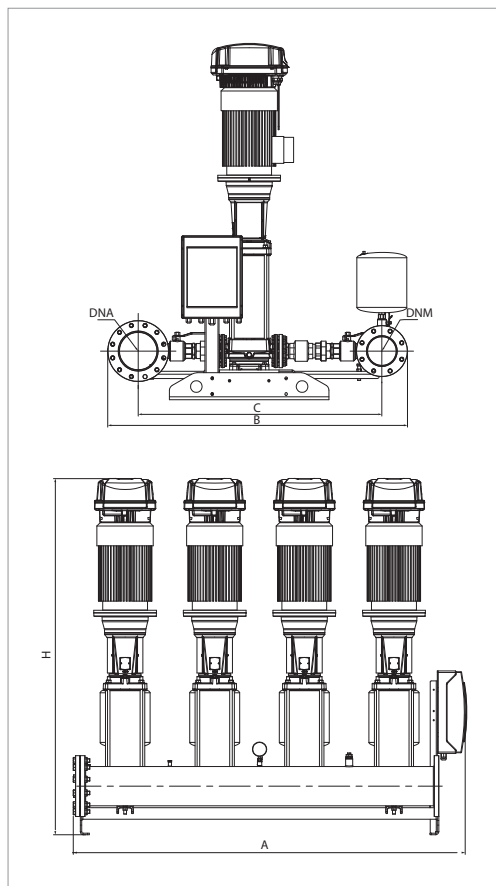

The performance curves are based on kinematic viscosity values = 1 mm²/s and density equal to 1000 kg/m³.
Curve tolerance according to ISO 9906.

Overall performance taking into account FOUR pumps working at the same time.

MODEL	PUMP+INVERTER POWER INPUT	P2 NOMINAL		In A	MCE/P MODEL	MAXIMUM FLOW RATE m ³ /h	MAX OBTAINABLE PRESSURE BAR	STANDARD PRESSURE BAR
		KW	HP					
4 NKVE 32/2 T MCE 400-50	3x400 50-60Hz	2x5,5	2x7,5	2x13,1	MCE55/P	180	4,8	4
4 NKVE 32/3-2 T MCE 400-50	3x400 50-60Hz	2x5,5	2x7,5	2x13,1	MCE55/P	180	6,0	5
4 NKVE 32/3 T MCE 400-50	3x400 50-60Hz	2x7,5	2x10	2x17,6	MCE110/P	180	7,3	6
4 NKVE 32/4 T MCE 400-50	3x400 50-60Hz	2x11	2x15	2x25,5	MCE110/P	180	9,8	8
4 NKVE 32/5-2 T MCE 400-50	3x400 50-60Hz	2x11	2x15	2x25,5	MCE110/P	180	10,9	9
4 NKVE 32/5 T MCE 400-50	3x400 50-60Hz	2x15	2x20	2x34	MCE150/P	180	12,2	10
4 NKVE 32/6 T MCE 400-50	3x400 50-60Hz	2x15	2x20	2x34	MCE150/P	180	14,6	12

MODEL	A	B	C	H	H1	H2	DNA	DNM	PACKING DIMENSIONS			WEIGHT kg
									L/A	L/B	H	
4 NKVE 32/2 T MCE 400-50	2195	1672	1340	1476	271	271	200	150	2660	1760	2200	952
4 NKVE 32/3-2 T MCE 400-50	2195	1672	1340	1558	271	271	200	150	2660	1760	2200	968
4 NKVE 32/3 T MCE 400-50	2195	1672	1340	1558	271	271	200	150	2660	1760	2200	1012
4 NKVE 32/4 T MCE 400-50	2195	1672	1340	1829	271	271	200	150	2660	1760	2200	1232
4 NKVE 32/5-2 T MCE 400-50	2195	1672	1340	1911	271	271	200	150	2660	1760	2200	1248
4 NKVE 32/5 T MCE 400-50	2195	1672	1340	1911	271	271	200	150	2660	1760	2200	1304
4 NKVE 32/6 T MCE 400-50	2195	1672	1340	1993	271	271	200	150	2660	1760	2200	1320

4 NKVE 45 -MCE/P - CONSTANT PRESSURE BOOSTER SETS

Pumped liquid temperature range: from -15 °C to +80 °C - Maximum ambient temperature: +40 °C - Max flow rate: 280 m³/h

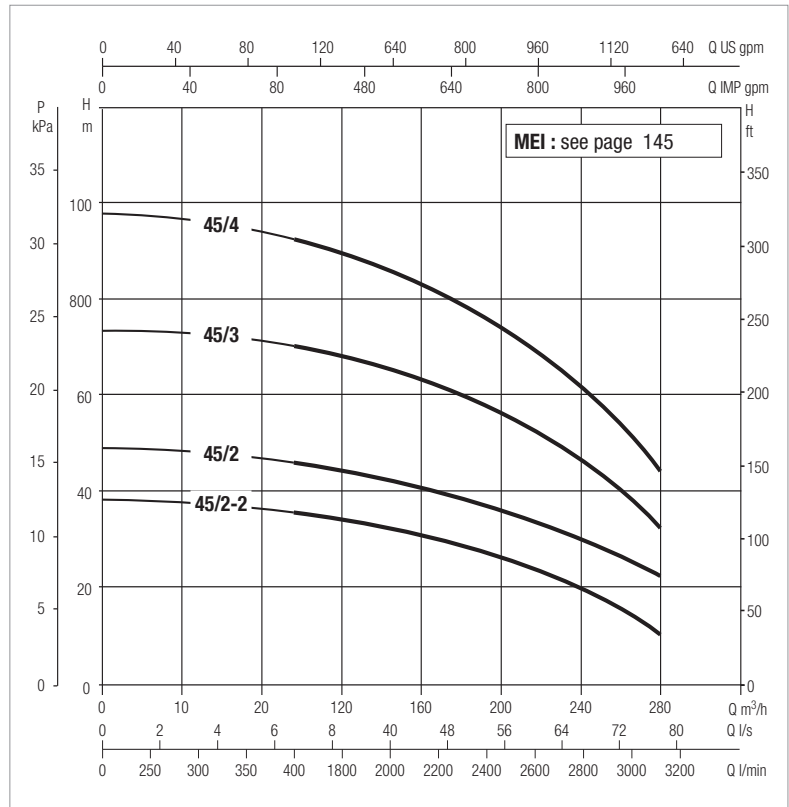
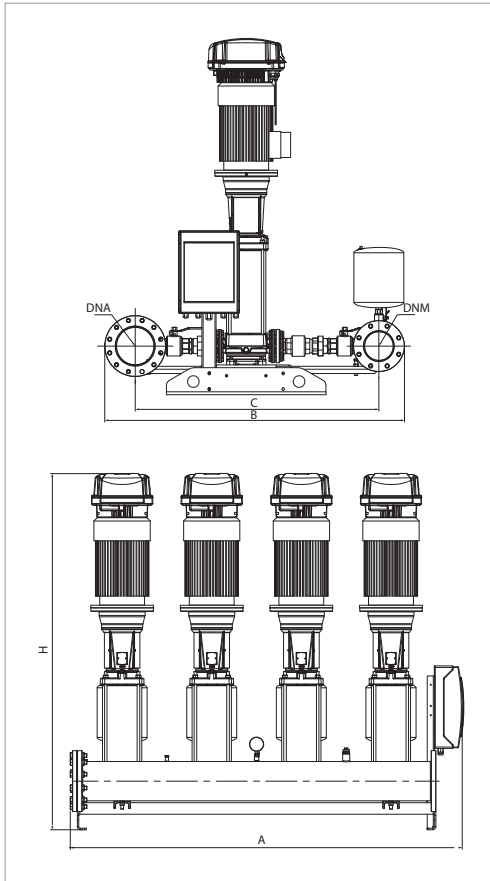

The performance curves are based on kinematic viscosity values = 1 mm²/s and density equal to 1000 kg/m³.
Curve tolerance according to ISO 9906.

Overall performance taking into account FOUR pumps working at the same time.

MODEL	PUMP+INVERTER POWER INPUT	P2 NOMINAL		In A	MCE/P MODEL	MAXIMUM FLOW RATE m³/h	MAX OBTAINABLE PRESSURE BAR	STANDARD PRESSURE BAR
		KW	HP					
4 NKVE 45/2-2 T MCE 400-50	3x400 50-60Hz	2x5,5	2x7,5	2x13,1	MCE55/P	280	3,8	3
4 NKVE 45/2 T MCE 400-50	3x400 50-60Hz	2x7,5	2x10	2x17,6	MCE110/P	280	4,8	4
4 NKVE 45/3 T MCE 400-50	3x400 50-60Hz	2x11	2x15	2x25,5	MCE110/P	280	7,3	6,5
4 NKVE 45/4 T MCE 400-50	3x400 50-60Hz	2x15	2x20	2x34	MCE150/P	280	9,7	8,5

MODEL	A	B	C	H	H1	H2	DNA	DNM	PACKING DIMENSIONS			WEIGHT kg
									L/A	L/B	H	
4 NKVE 45/2-2 T MCE 400-50	2195	1813	1440	1515	306	306	250	200	2660	1760	2200	976
4 NKVE 45/2 T MCE 400-50	2195	1813	1440	1565	306	306	250	200	2660	1760	2200	1020
4 NKVE 45/3 T MCE 400-50	2195	1813	1440	1782	306	306	250	200	2660	1760	2200	1240
4 NKVE 45/4 T MCE 400-50	2195	1813	1440	1864	306	306	250	200	2660	1760	2200	1312

2 NKVE 10-15-20 ADAC

CONSTANT PRESSURE SETS WITH "ADAC" MULTI INVERTER SYSTEM



ADAC
PAGE 172

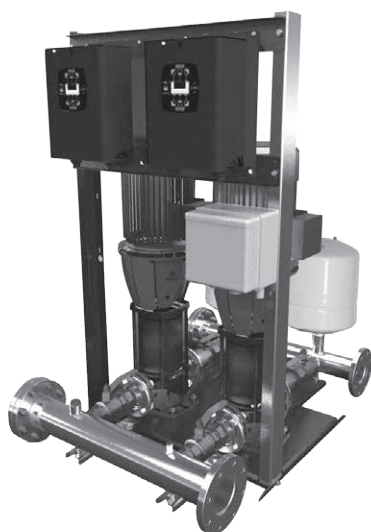

TECHNICAL DATA

Line voltage: 400V three phase.
Voltage of electric pump: 400V three phase.
Power frequency: 50-60 Hz.
Installation: vertical only.
Pumped liquid temperature range: from 0 °C to 80 °C.
Maximum ambient temperature: 40°C.
Max pressure: 14bar.
Pumped liquid: clean, free from solids.
Operating range: from 4 to 58 m³/h.
Pressure regulation range: 3 to 14 bar.
Protection class: IP20.

APPLICATIONS

The sets with on-board inverter have been designed and manufactured to meet the constant pressure requirements of modern system engineering solutions. The constant pressure adjustment is a requirement in the most varied sectors: Water pipelines, Irrigation, Industry, Hotel, Residential building, Spas. The fundamental concept that has driven our Engineers in developing these pumps sets, was to offer a simple to use, flexible, and extremely reliable product. Differently from traditional fixed speed pumps, inverter driven pumps give the possibility to adapt the performance curve to the needs of the system. In the most classic case, inverter driven pumps are used to maintain constant pressure in the system against variations in the requested flow rate, avoiding pressure fluctuations caused by small flow rate variations.

ADVANTAGES OF USE

Operating pressure stability – Excellent energy savings (up to 60 %) – Reduced hammering effects – Reduced space requirements – Less maintenance – Reduced pump wear – Less power factor correction required – Less water consumption – Integrated protections.

CONSTRUCTION FEATURES

The sets with ADAC inverters are built in the standard version with two centrifugal electric pumps, completely assembled on galvanised steel base, tested and ready for installation. Complete with isolator and check valves for each pump, suction and delivery manifolds, expansion vessels, pressure sensor, inverter, protection control unit. (possibility of optional flow sensor for pressure control).

ADAC MULTI INVERTER SYSTEM

The inverter continuously adjusts the rotation speed of the electric pump, keeping the pressure constant, even when the flow rate varies. The other electric pumps, also with variable speed, are activated in cascade after the first one has reached maximum speed. Through modulation, they compensate the pressure fluctuations of the system.

For every operating cycle, it is possible to switch the restart to a different pump, therefore ensuring even use of all electric pumps.

It is possible to set operation times for each individual pump, switching to another pump after such set times.

The "SP" pressure can be adjusted by the user using the "+" and "-" keys found on the ADAC (as a rule, all the pumps are set to the same pressure value). With the new ADAC, it is sufficient to set the data on one of the devices, and it will automatically be propagated to the other pumps of the system.

ELECTRIC COMPONENTS SUPPLIED

ADAC inverter with the following features:

- Abnormal voltage protection.
- Adjustable amperometric protection.
- Dry run protection (without minimum manometer).
- Output phases short circuit protection.
- Overtemperature and overvoltage protection.
- Anti-seizing and anti-freeze functions.
- Pressure sensor fault.
- Thermal magnetic protection control unit (simplified connection).
- Pressure sensor on the delivery manifold.

2 NKVE 10/6 - ADAC - RESIDENTIAL CONSTANT PRESSURE BOOSTER SETS

Pumped liquid temperature range: from -15 °C to +80 °C - Maximum ambient temperature: +40 °C - Max flow rate: 26 m³/h

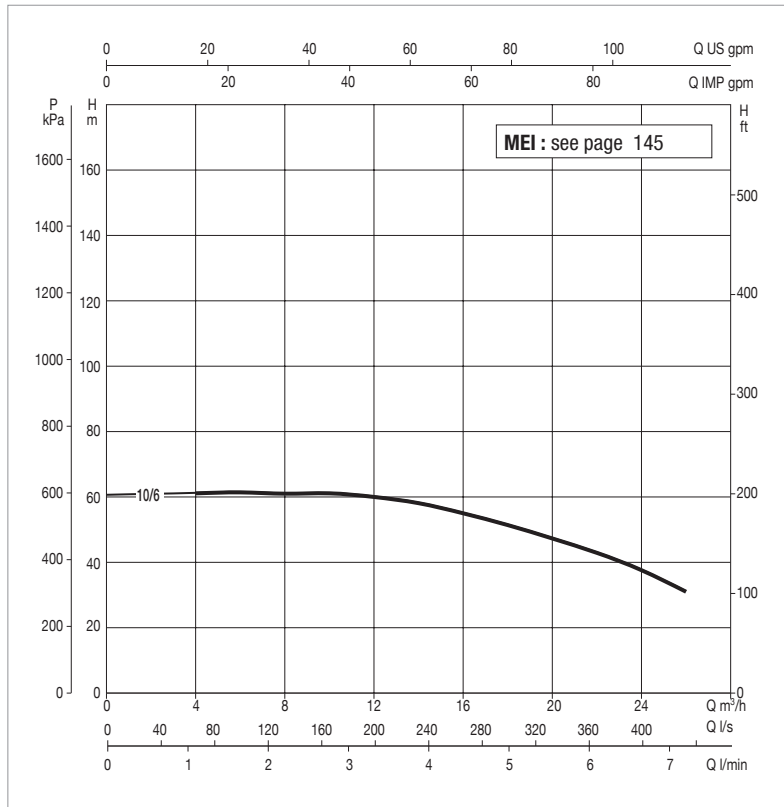
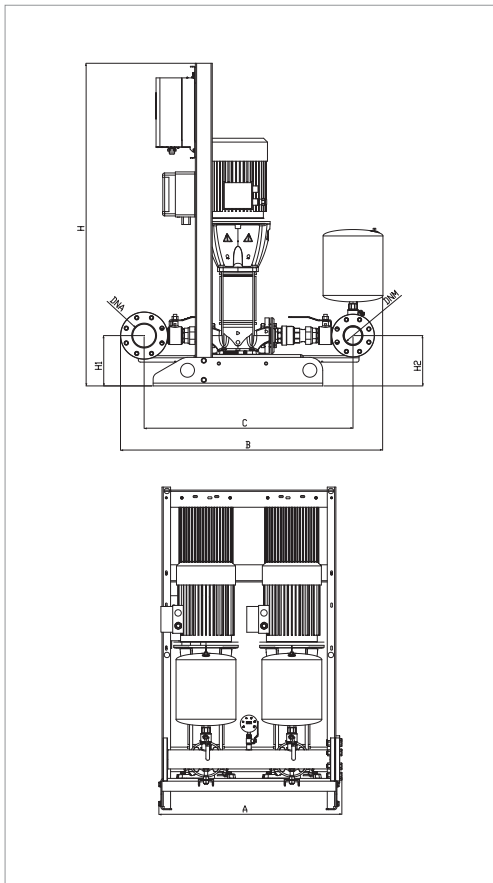

The performance curves are based on kinematic viscosity values = 1 mm²/s and density equal to 1000 kg/m³.
Curve tolerance according to ISO 9906.

Overall performance taking into account TWO pumps working at the same time.

MODEL	POWER INPUT	P2 NOMINAL		In A	INVERTER MODEL	CONTROL PANEL MODEL	MAXIMUM FLOW RATE m ³ /h	MAX OBTAINABLE PRESSURE BAR	STANDARD PRESSURE BAR
		kW	HP						
2 NKVE 10/6 T ADAC 400-50	3 x 400 50-60 Hz	2x2.2	2x3	2x5,4	AD T/T 3.0 AC	E2G11T MCE (16A MAX) 400V C/CAVI	26	6	5

MODEL	A	B	C	H	H1	H2	DNA	DNM	WEIGHT	PACKING (wxhxd)
2 NKVE 10/6 T ADAC 400-50	853	1060	875	1503	225	225	2" 1/2	2" 1/2	207	1000x1400x2000

2 NKVE 15/3 - 15/4 - ADAC - RESIDENTIAL CONSTANT PRESSURE BOOSTER SETS

Pumped liquid temperature range: from -15 °C to +80 °C - Maximum ambient temperature: +40 °C - Max flow rate: 48 m³/h

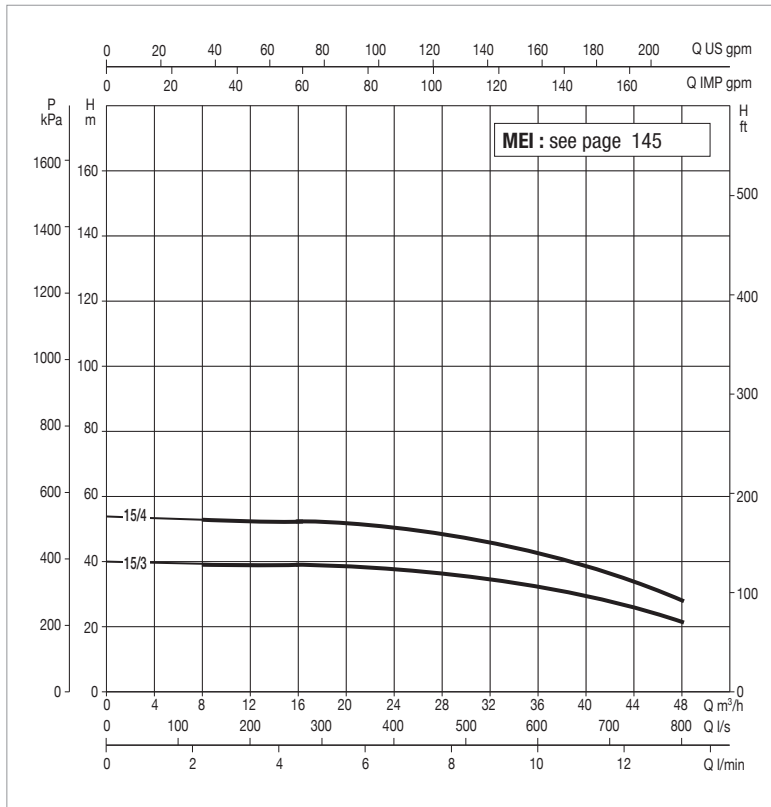
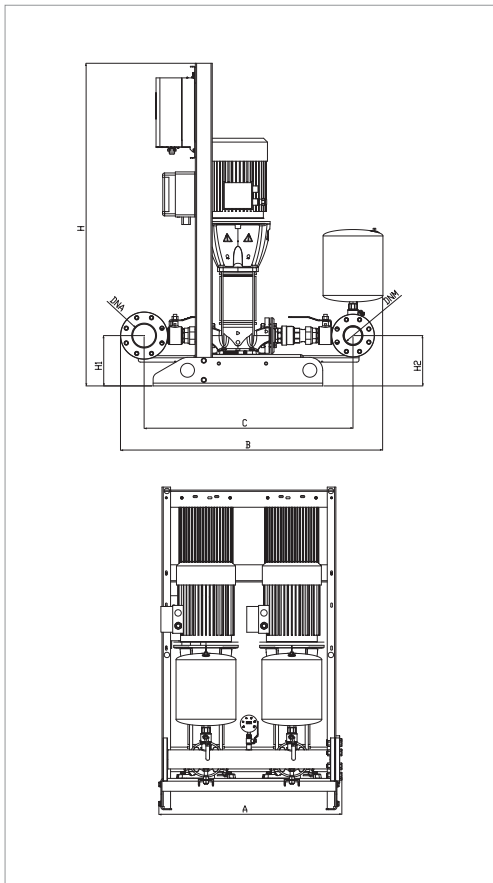

The performance curves are based on kinematic viscosity values = 1 mm²/s and density equal to 1000 kg/m³.
Curve tolerance according to ISO 9906.

Overall performance taking into account TWO pumps working at the same time.

MODEL	POWER INPUT	P2 NOMINAL		In A	INVERTER MODEL	CONTROL PANEL MODEL	MAXIMUM FLOW RATE m ³ /h	MAX OBTAINABLE PRESSURE BAR	STANDARD PRESSURE BAR
		kW	HP						
2 NKVE 15/3 T ADAC 400-50	3 x 400 50-60 Hz	2x3	2x4	2x7.37	AD T/T 3.0 AC	E2G11T MCE (16A MAX) 400V CABLE CONN.	48	4	3.5
2 NKVE 15/4 T ADAC 400-50	3 x 400 50-60 Hz	2x4	2x5.5	2x10.1	AD T/T 3.0 AC	E2G11T MCE (16A MAX) 400V CABLE CONN.	48	5	4.0

MODEL	A	B	C	H	H1	H2	DNA	DNM	WEIGHT	PACKING (wxhxd)
2 NKVE 15/3 T ADAC 400-50	853	1221	973	1503	235	235	100	80	258	1000x1400x2000
2 NKVE 15/4 T ADAC 400-50	853	1221	973	1503	235	235	100	80	278	1000x1400x2000

2 NKVE 20/4 - ADAC - RESIDENTIAL CONSTANT PRESSURE BOOSTER SETS

Pumped liquid temperature range: from -15 °C to +80 °C - Maximum ambient temperature: +40 °C - Max flow rate: 58 m³/h

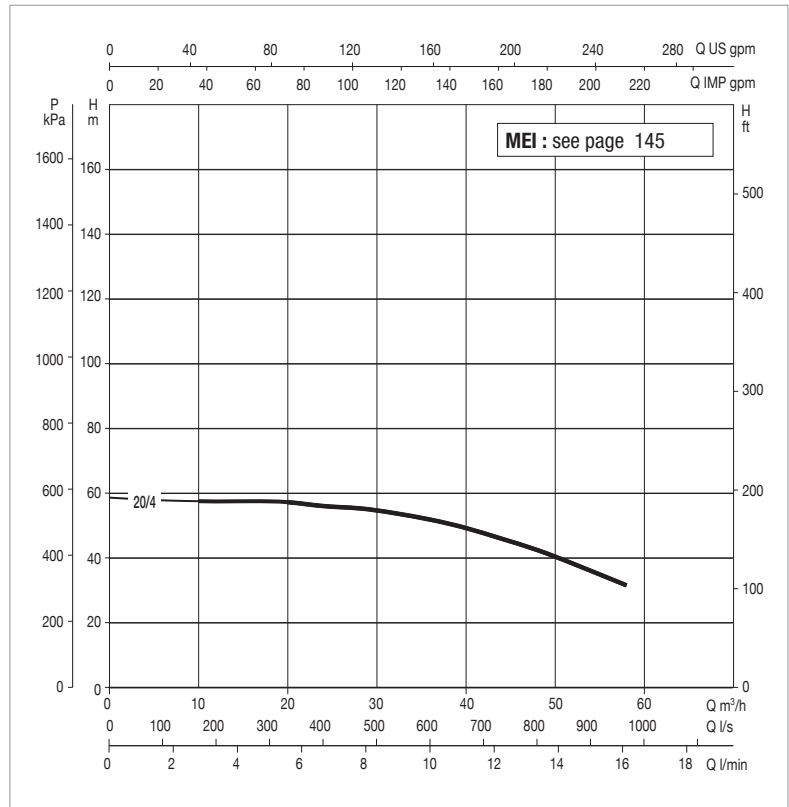
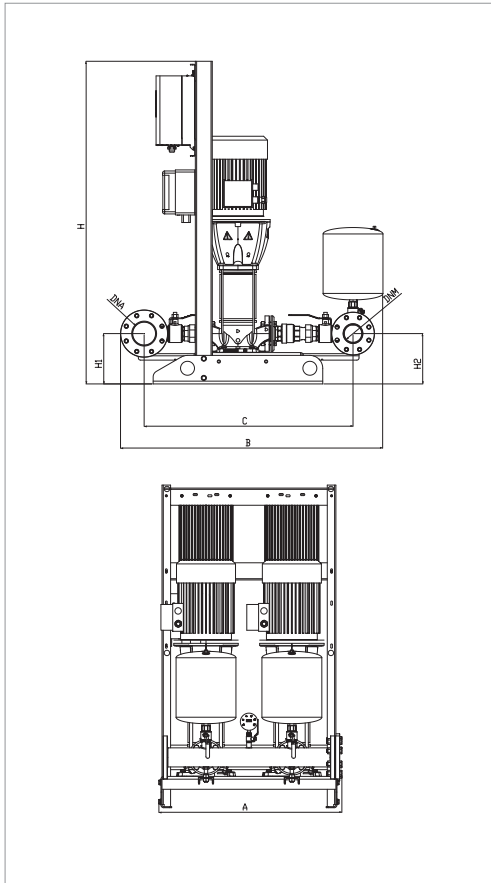

The performance curves are based on kinematic viscosity values = 1 mm²/s and density equal to 1000 kg/m³.
Curve tolerance according to ISO 9906.

Overall performance taking into account TWO pumps working at the same time.

MODEL	POWER INPUT	P2 NOMINAL		In A	INVERTER MODEL	CONTROL PANEL MODEL	MAXIMUM FLOW RATE m ³ /h	MAX OBTAINABLE PRESSURE BAR	STANDARD PRESSURE BAR
		kW	HP						
2 NKVE 20/4 T ADAC 400-50	3 x 400 50-60 Hz	2x2.5	2x3	2x7.5	AD T/T 4.0 AC	E2G11T MCE (16A MAX) 400V CABLE CONN.	58	6	5

MODEL	A	B	C	H	H1	H2	DNA	DNM	WEIGHT	PACKING (wxhxd)
2 NKVE 20/4 T ADAC 400-50	853	1221	973	1503	235	235	100	80	280	1000x1400x2000

2/3 KVE 3-6-10

INVERTER DRIVEN CONSTANT PRESSURE BOOSTER SETS WITH 2 OR 3 MULTISTAGE CENTRIFUGAL PUMPS.



TECHNICAL DATA

Operating range: from 1,8 to 41 m³/h.

Pumped liquid: clean, free of solids and abrasives, non viscous, non aggressive, non crystallised and chemically neutral, with properties similar to water.

Pumped liquid temperature range: from 0 °C to +85 °C.

Maximum ambient temperature: +40°C.

Maximum operating pressure: PN16.

Special executions on request: contact our sales network.

Protection class: IP44.

APPLICATIONS

Water lifting sets particularly suited for domestic use, and small civil, agricultural, or industrial systems. The use of vertical axis multistage centrifugal electric pumps ensures high performance results.

Their main features are limited space requirements, sturdiness, absolute reliability, and extremely quiet operation.

CONSTRUCTION FEATURES SETS WITH 2 -3 PUMPS

HYDRAULIC SECTION

2 - 3 KV 3 - 6 - 10 vertical multistage electric pumps.

Tropicalized galvanized sheet steel base complete with 4 rubber anti-vibration feet.

Tropicalized galvanized steel suction and delivery manifolds, threaded for 2 KVE 3-6-10 and 3 KV 3-6 sets, flanged for 3 KVE 10 sets.

Plugs or blind flanges for closing the manifolds.

Ball valves with unions on the suction and delivery ports of each pump.

Check valves on the suction port of each pump.

2 - 3 membrane tanks.

Radial manometer with isolator valve.

Electric control panel support in galvanized steel.

ELECTRICAL SECTION

See the characteristics of the control panel with inverter at the start of the section.

The sets are supplied in a sturdy cardboard packaging on wooden pallet and instruction leaflet with electric diagram.

INVERTER DIAGRAM

The inverter continuously adjusts the rotation speed of the electric pump, keeping the pressure constant, even when the flow rate varies.

The other electric pumps, with fixed speed, are activated in cascade after the first one has reached maximum speed. Through modulation, they compensate the pressure fluctuations of the system. For every operating cycle, it is possible to switch the restart to a different pump, therefore ensuring even use of all electric pumps.

It is possible to set operation times for each individual pump, switching to another pump after such set times.

The "SP" pressure can be adjusted by the user using two "+" and "-" keys on the electric control panel.

MATERIALS

N.	PARTS	MATERIALS
4	IMPELLER	TECHNOPOLYMER B
6	DIFFUSER	TECHNOPOLYMER B
7A	PUMP SHAFT	AISI 416 STAINLESS STEEL X12 CrS 13 UNI 6900/71
16	MECHANICAL SEAL	CARBON / CERAMIC
28	OR RING	EPDM RUBBER
69	LINER	AISI 304 STAINLESS STEEL X5 CrNi 1810 UNI 6900/71
95	OR RING	EPDM RUBBER
96	SUCTION BODY	CAST IRON 200 UNI ISO 185
97	DELIVERY BODY	CAST IRON 200 UNI ISO 185
98	DIFFUSER BODY	TECHNOPOLYMER B

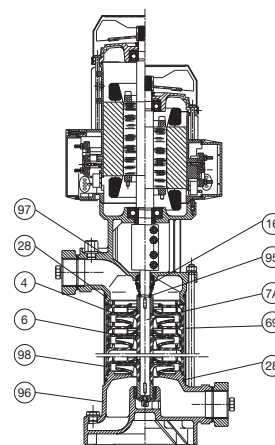

2 KVE 3 - RESIDENTIAL CONSTANT PRESSURE BOOSTER SETS

Pumped liquid temperature range: from -15 °C to +85 °C - Maximum ambient temperature: +40 °C - Max flow rate: 14.4 m³/h

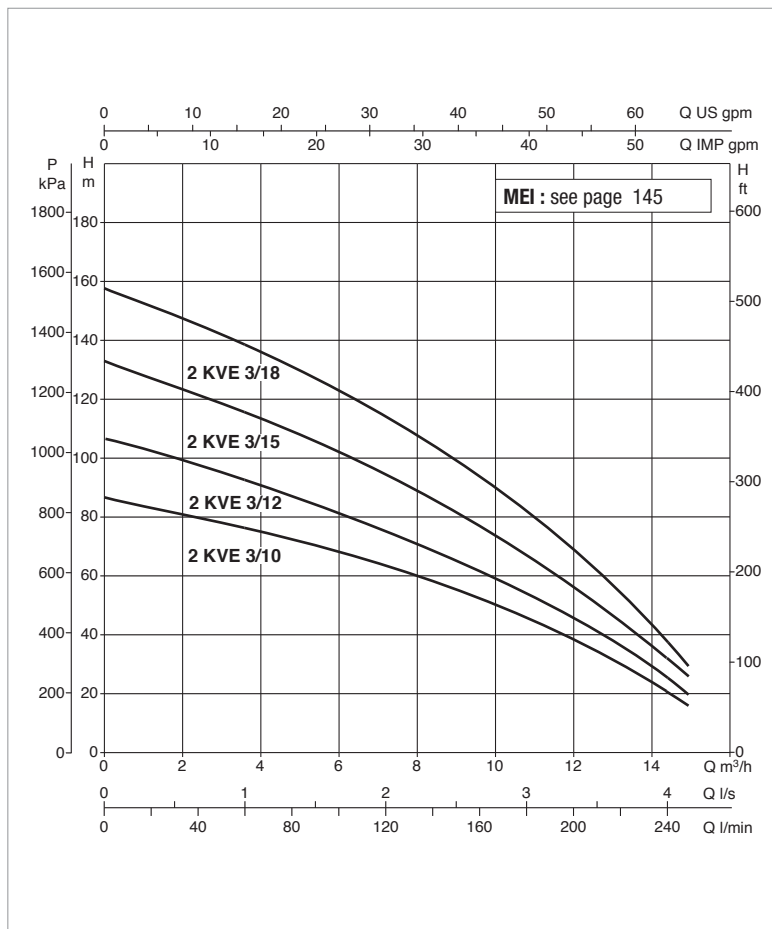
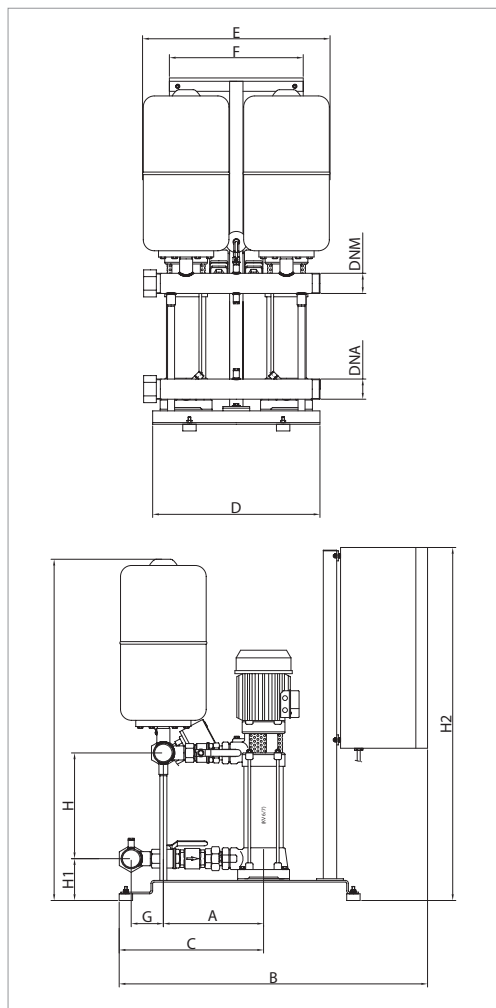

The performance curves are based on kinematic viscosity values = 1 mm²/s and density equal to 1000 kg/m³.
Curve tolerance according to ISO 9906.

Overall performance taking into account TWO pumps working at the same time.

MODEL	POWER INPUT 50 Hz	P2 NOMINAL		In A	MIN - MAX Q m ³ /h	ADJUSTABLE PRESSURE MAX - MIN BAR
		kW	HP			
2 KVE 3/10	3x400 V	2x1,1	2x1,5	2x3,2	2 - 14.4	7 - 2
2 KVE 3/12	3x400 V	2x1,5	2x2	2x3,7	2 - 14.4	9 - 2.5
2 KVE 3/15	3x400 V	2x1,84	2x2,5	2x4,3	2 - 14.4	11 - 3
2 KVE 3/18	3x400 V	2x2,2	2x3	2x5,8	2 - 14.4	13 - 4

MODEL	A	B	C	D	E	F	G	H	H1	H2	MANIFOLDS		WEIGHT kg
											DNA	DNM	
2 KVE 3/10	292	922	432	500	560	400	100	1117	412	1055	2"	2"	123
2 KVE 3/12	292	922	432	500	560	400	100	1181	476	1055	2"	2"	131
2 KVE 3/15	292	922	432	500	560	400	100	1277	572	1055	2"	2"	134
2 KVE 3/18	292	922	432	500	560	400	100	1373	668	1055	2"	2"	141

2 KVE 6 - RESIDENTIAL CONSTANT PRESSURE BOOSTER SETS

Pumped liquid temperature range: from -15 °C to +85 °C - Maximum ambient temperature: +40 °C - Max flow rate: 17 m³/h

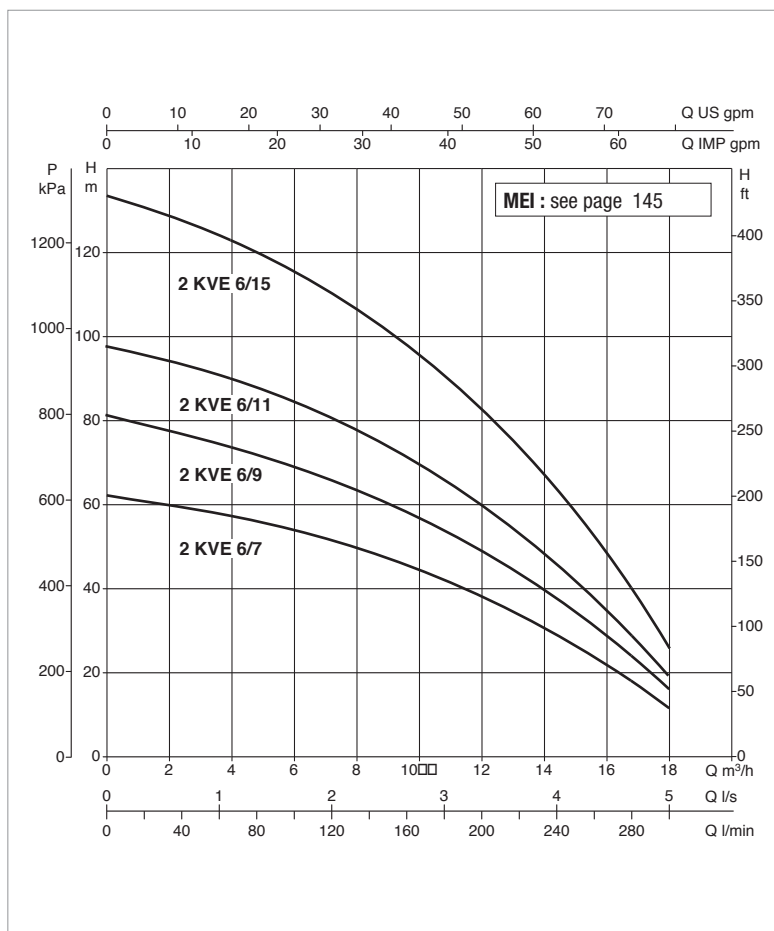
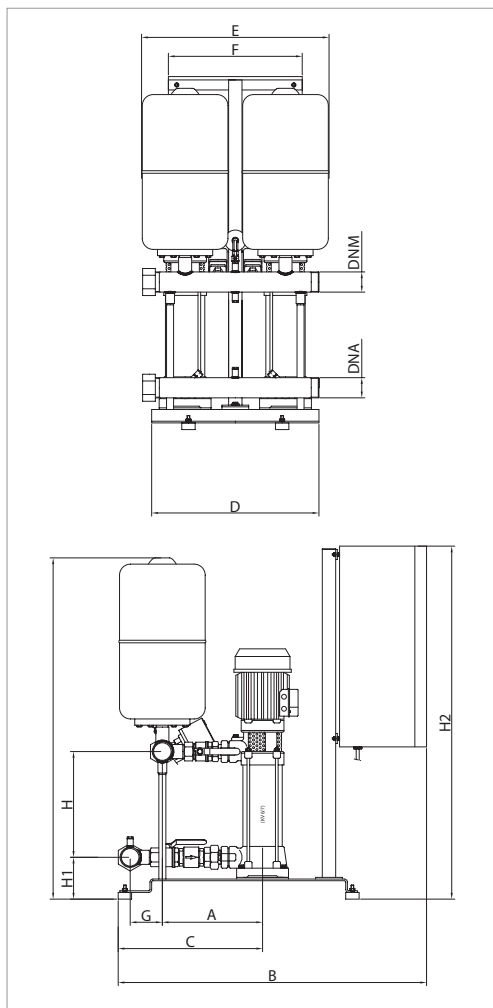

The performance curves are based on kinematic viscosity values = 1 mm²/s and density equal to 1000 kg/m³.
Curve tolerance according to ISO 9906.

Overall performance taking into account TWO pumps working at the same time.

MODEL	POWER INPUT 50 Hz	P2 NOMINAL		In A	MIN - MAX Q m ³ /h	ADJUSTABLE PRESSURE MAX - MIN BAR
		kW	HP			
2 KVE 6/7	3x400 V	2x1,1	2x1,5	2x2,9	2 - 17	5 - 2
2 KVE 6/9	3x400 V	2x1,5	2x2	2x3,6	2 - 17	7 - 2.5
2 KVE 6/11	3x400 V	2x1,84	2x2,5	2x4,2	2 - 17	9 - 3
2 KVE 6/15	3x400 V	2x2,2	2x3	2x6,3	2 - 17	12 - 4

MODEL	A	B	C	D	E	F	G	H	H1	H2	MANIFOLDS		WEIGHT kg
											DNA	DNM	
2 KVE 6/7	292	922	432	500	560	400	100	1021	316	1055	2"	2"	125
2 KVE 6/9	292	922	432	500	560	400	100	1085	380	1055	2"	2"	121
2 KVE 6/11	292	922	432	500	560	400	100	1149	444	1055	2"	2"	127
2 KVE 6/15	292	922	432	500	560	400	100	1277	572	1055	2"	2"	147

2 KVE 10 - RESIDENTIAL CONSTANT PRESSURE BOOSTER SETS

Pumped liquid temperature range: from -15 °C to +85 °C - Maximum ambient temperature: +40 °C - Max flow rate: 29 m³/h

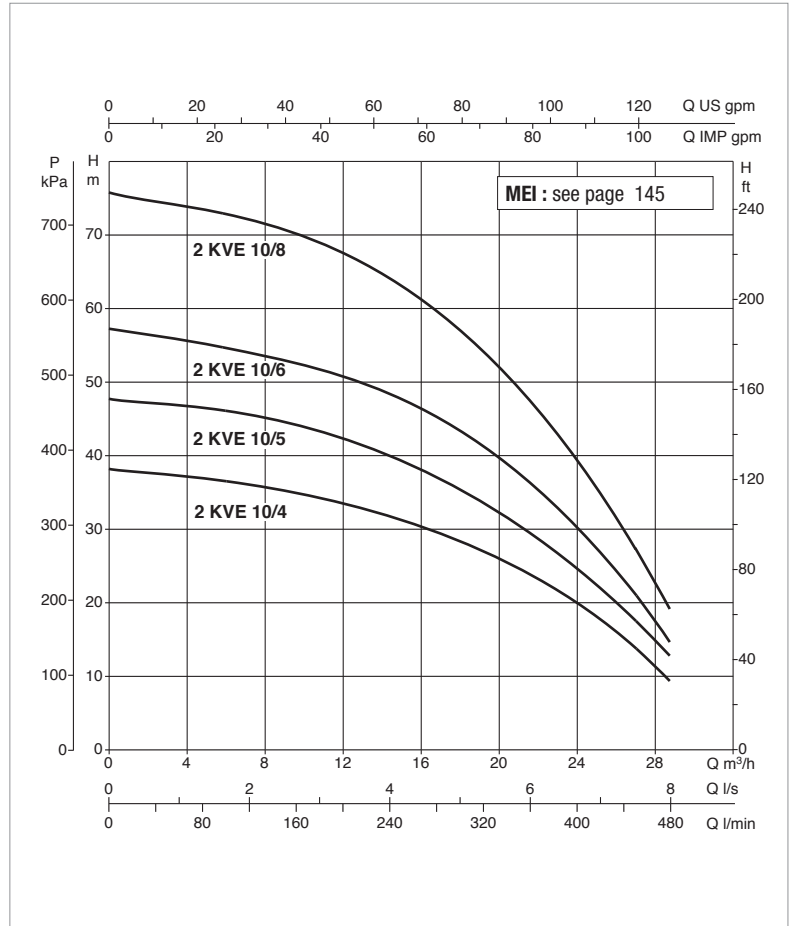
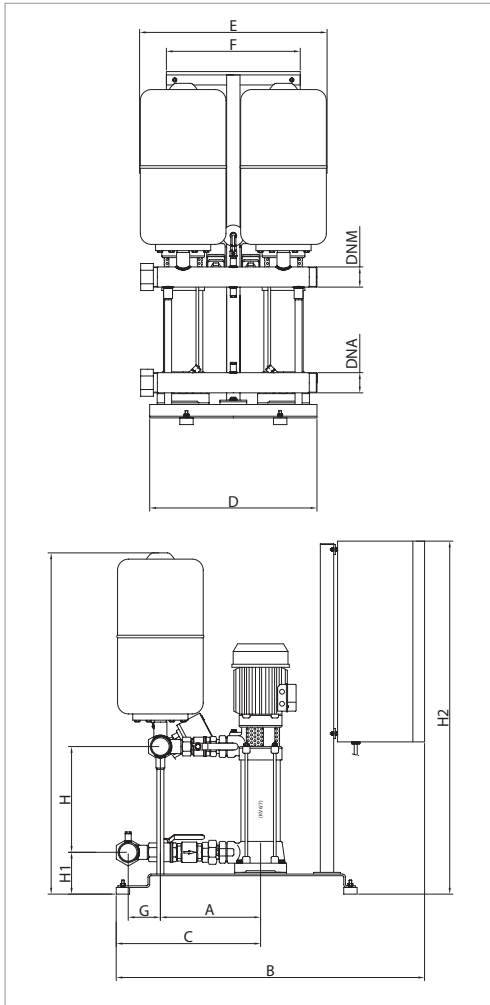

The performance curves are based on kinematic viscosity values = 1 mm²/s and density equal to 1000 kg/m³.
Curve tolerance according to ISO 9906.

Overall performance taking into account TWO pumps working at the same time.

MODEL	POWER INPUT 50 Hz	P2 NOMINAL		In A	MIN - MAX Q m ³ /h	ADJUSTABLE PRESSURE MAX - MIN BAR
		kW	HP			
2 KVE 10/4	3x400 V	2x1,1	2x1,5	2x3,5	3 - 29	3,5 - 1,5
2 KVE 10/5	3x400 V	2x1,5	2x2	2x3,9	3 - 29	4,5 - 2
2 KVE 10/6	3x400 V	2x1,5	2x2	2x5	3 - 29	5 - 2
2 KVE 10/8	3x400 V	2x2,2	2x3	2x6,8	3 - 29	7 - 3

MODEL	A	B	C	D	E	F	G	H	H1	H2	MANIFOLDS		WEIGHT kg
											DNA	DNM	
2 KVE 10/4	300	922	432	500	560	400	100	925	220	1055	2 1/2"	2 1/2"	117
2 KVE 10/5	300	922	432	500	560	400	100	957	252	1055	2 1/2"	2 1/2"	130
2 KVE 10/6	300	922	432	500	560	400	100	989	284	1055	2 1/2"	2 1/2"	135
2 KVE 10/8	300	922	432	500	560	400	100	1053	348	1055	2 1/2"	2 1/2"	133

3 KVE 3 - RESIDENTIAL CONSTANT PRESSURE BOOSTER SETS

Pumped liquid temperature range: from -15 °C to +85 °C - Maximum ambient temperature: +40 °C - Max flow rate: 24 m³/h

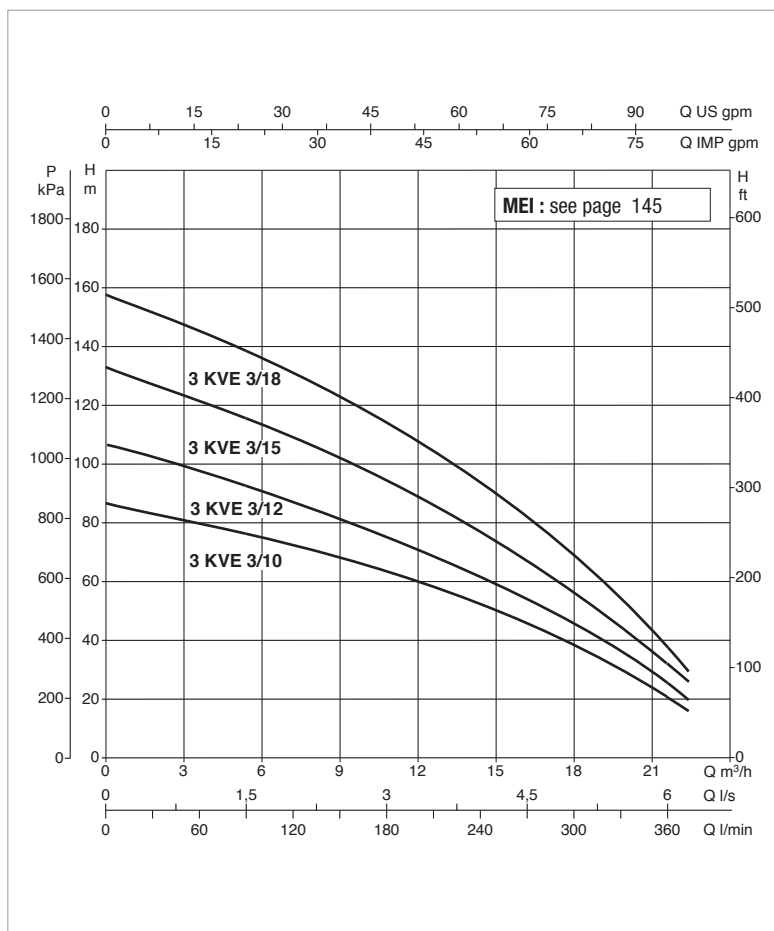
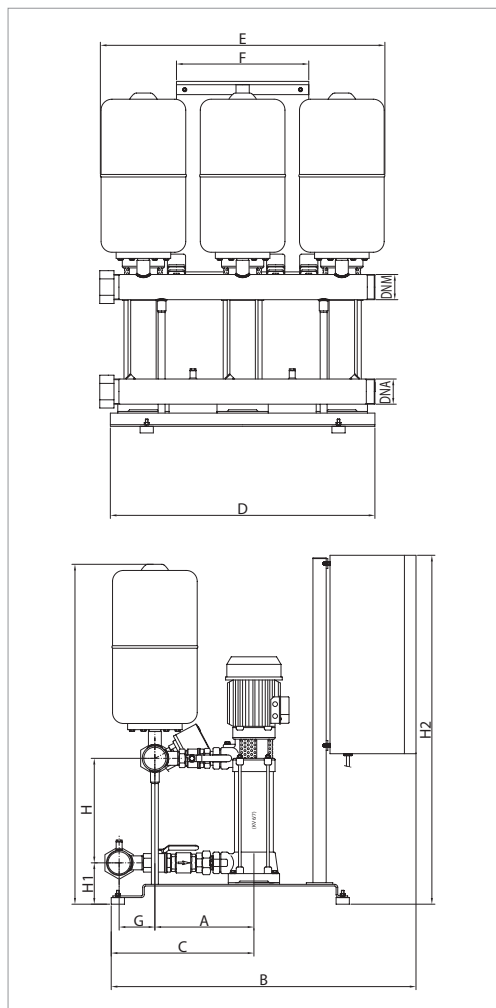

The performance curves are based on kinematic viscosity values = 1 mm²/s and density equal to 1000 kg/m³.
Curve tolerance according to ISO 9906.

Overall performance taking into account THREE pumps working at the same time.

MODEL	POWER INPUT 50 Hz	P2 NOMINAL		In A	MIN - MAX Q m ³ /h	ADJUSTABLE PRESSURE MAX - MIN BAR
		kW	HP			
3 KVE 3/10	3x400 V	3x1,1	3x1,5	3x3,2	2 - 24	7 - 2
3 KVE 3/12	3x400 V	3x1,47	3x2	3x3,7	2 - 24	9 - 2.5
3 KVE 3/15	3x400 V	3x1,87	3x2,5	3x4,3	2 - 24	11 - 3
3 KVE 3/18	3x400 V	3x2,2	3x3	3x5,8	2 - 24	13 - 4

MODEL	A	B	C	D	E	F	G	H	H1	H2	MANIFOLDS		WEIGHT kg
											DNA	DNM	
3 KVE 3/10	300	922	432	800	860	400	100	1125	412	1055	2 1/2"	2 1/2"	248
3 KVE 3/12	300	922	432	800	860	400	100	1189	476	1055	2 1/2"	2 1/2"	250
3 KVE 3/15	300	922	432	800	860	400	100	1285	572	1055	2 1/2"	2 1/2"	253
3 KVE 3/18	300	922	432	800	860	400	100	1381	668	1055	2 1/2"	2 1/2"	255

3 KVE 6 - RESIDENTIAL CONSTANT PRESSURE BOOSTER SETS

Pumped liquid temperature range: from -15 °C to +85 °C - Maximum ambient temperature: +40 °C - Max flow rate: 27 m³/h

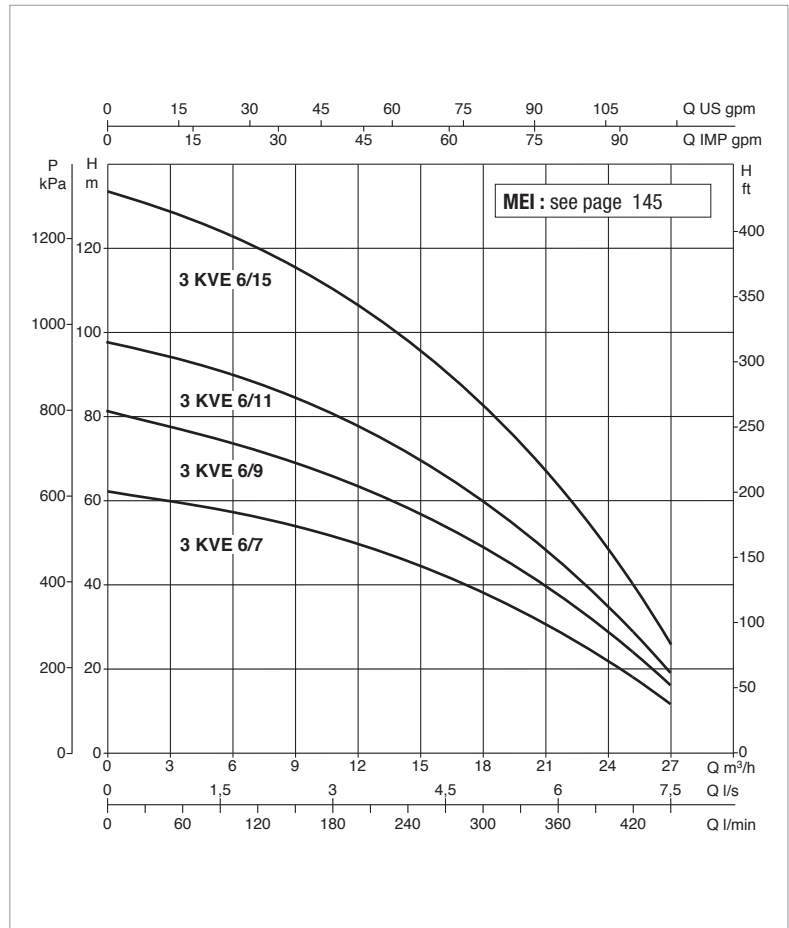
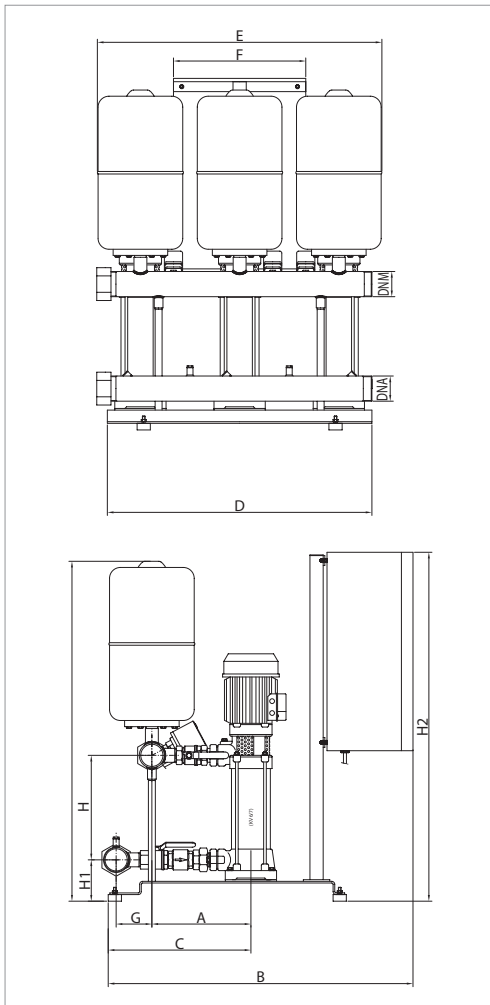

The performance curves are based on kinematic viscosity values = 1 mm²/s and density equal to 1000 kg/m³.
Curve tolerance according to ISO 9906.

Overall performance taking into account THREE pumps working at the same time.

MODEL	POWER INPUT 50 Hz	P2 NOMINAL		In A	MIN - MAX Q m ³ /h	ADJUSTABLE PRESSURE MAX - MIN BAR
		kW	HP			
3 KVE 6/7	3x400 V	3x1,1	3x1,5	3x2,9	2 - 27	5 - 2
3 KVE 6/9	3x400 V	3x1,47	3x2	3x3,6	2 - 27	7 - 2.5
3 KVE 6/11	3x400 V	3x1,84	3x2,5	3x4,2	2 - 27	9 - 3
3 KVE 6/15	3x400 V	3x2,2	3x3	3x6,3	2 - 27	12 - 4

MODEL	A	B	C	D	E	F	G	H	H1	H2	MANIFOLDS		WEIGHT kg
											DNA	DNM	
3 KVE 6/7	300	922	432	800	860	400	100	1029	316	1055	2 1/2"	2 1/2"	125
3 KVE 6/9	300	922	432	800	860	400	100	1093	380	1055	2 1/2"	2 1/2"	248
3 KVE 6/11	300	922	432	800	860	400	100	1157	444	1055	2 1/2"	2 1/2"	256
3 KVE 6/15	300	922	432	800	860	400	100	1285	572	1055	2 1/2"	2 1/2"	265

3 KVE 10 - RESIDENTIAL CONSTANT PRESSURE BOOSTER SETS

Pumped liquid temperature range: from -15 °C to +85 °C - Maximum ambient temperature: +40 °C - Max flow rate: 43 m³/h

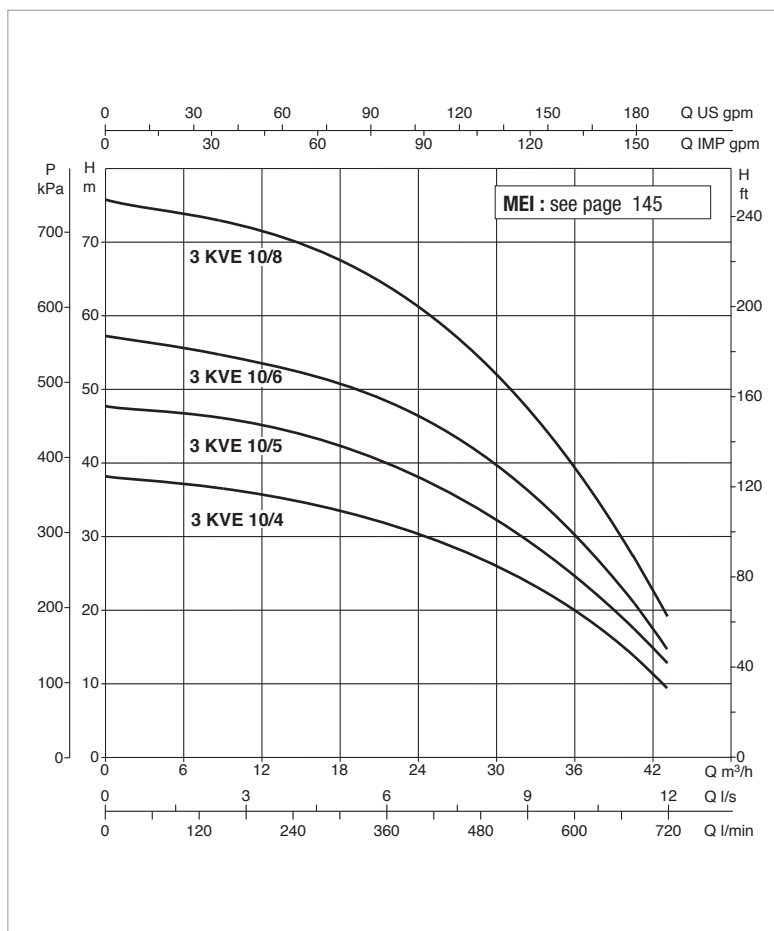
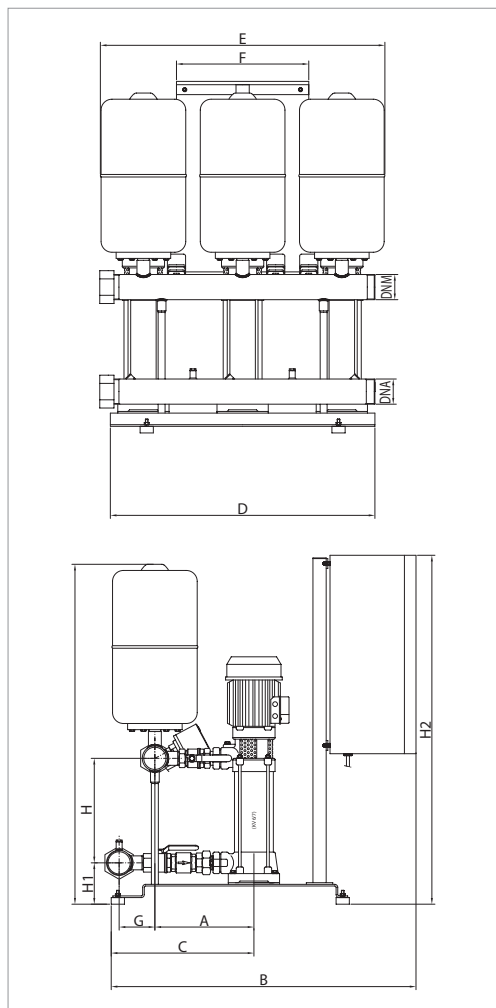

The performance curves are based on kinematic viscosity values = 1 mm²/s and density equal to 1000 kg/m³.
Curve tolerance according to ISO 9906.

Overall performance taking into account THREE pumps working at the same time.

MODEL	POWER INPUT 50 Hz	P2 NOMINAL		In A	MIN - MAX Q m ³ /h	ADJUSTABLE PRESSURE MAX - MIN BAR
		kW	HP			
3 KVE 10/4	3x400 V	3x1,1	3x1,5	3x3,5	3 - 43	3,5 - 1,5
3 KVE 10/5	3x400 V	3x1,47	3x2	3x3,9	3 - 43	4,5 - 2
3 KVE 10/6	3x400 V	3x1,84	3x2,5	3x5	3 - 43	5 - 2
3 KVE 10/8	3x400 V	3x2,2	3x3	3x6,8	3 - 43	7 - 3

MODEL	A	B	C	D	E	F	G	H	H1	H2	I	L	M	MANIFOLDS		WEIGHT kg
														DNA	DNM	
3 KVE 10/4	307	997	922	432	860	400	100	938	220	1055	76	910	800	DN 80	DN 80	268
3 KVE 10/5	307	997	922	432	860	400	100	970	252	1055	76	910	800	DN 80	DN 80	269
3 KVE 10/6	307	997	922	432	860	400	100	1002	284	1055	76	910	800	DN 80	DN 80	271
3 KVE 10/8	307	997	922	432	860	400	100	1066	348	1055	76	910	800	DN 80	DN 80	267



TECHNICAL DATA

- Operating range:** from 1 to 14.4 m³/h.
- Pumped liquid:** clean, free of solids and abrasives, non viscous, non aggressive, non crystallised and chemically neutral, with properties similar to water.
- Pumped liquid temperature range:** from 0 °C to +35°C.
- Maximum ambient temperature:** +40°C.
- Maximum operating pressure:** PN10.
- Special executions on request:** contact our sales network.
- Protection class:** IP44.
- IE2 motors as standard from 0,75 kW to 5,5 kW - IE3 ≥ 7,5 kW.

APPLICATIONS

Water lifting sets particularly suited for domestic use, and small civil, agricultural, or industrial systems. The JET self-priming pumps used have the characteristic of also working when water, gas, or small amounts of sand are present in the water. These pumps are invaluable when drawing water from artesian wells and in case of suction difficulties. Their main features are utmost reliability, simple operation, and the fact that no maintenance is required. The sets are supplied as standard with tanks and with air supply connector.

CONSTRUCTION FEATURES

HYDRAULIC SECTION

2 JET centrifugal self-priming pumps. Tropicalized galvanized sheet steel base complete with 4 rubber anti-vibration feet. Suction and delivery manifolds in tropicalized galvanized steel. 2 membrane tanks. Ball valves with unions on the suction and delivery ports of each pump. Check valves on the suction port of each pump. 1 1/4" air supply connection at the suction of each pump. 2 tropicalized galvanized cast iron female plugs for closing the manifolds. 1 pressure transmitter on the delivery manifold (pressure detection).

ELECTRICAL SECTION

Supplied in an IP 55 protection class self-extinguishing thermoplastic material box, the control panel protects the electric pumps from abnormal conditions such as: overload and overtemperature (with automatic reset), short circuit (with fuses - Plus model only), pump current surges (amperometric protection), abnormal voltage, dry run, quick starts, pressure sensor fault, or inconsistency of the external protection commands.

FRONT PANEL COMPONENTS:

General disconnecter with padlockable door lock. AUT-0-MAN operation selection pushbuttons. Alarm RESET pushbutton. Display for all models. Operation, stop, alarm notification lamps.

PANEL INTERNAL COMPONENTS:

Electronic control card with protection fuses and contactors. Power input connection terminals (single phase or three phase). Dry run or overpressure pressure switch connection terminals (optional). Alarm notification N.O. contacts.

Function selection mini dip switch (pressure transmitter or pressure switches, standard or additional tanks).

The electric control panel is ready for the connection of:

Dry run protection float or pressure switch kit (*).

Overpressure stop pressure switch kit (*).

(* available separately as optional).

The sets are supplied in a sturdy cardboard packaging on wooden pallet and installation / maintenance manual with electric diagram.

MATERIALS

N.	PARTS*	MATERIALS
1	PUMP BODY	CAST IRON 200 UNI ISO 185
3	SUPPORT	DIE-CAST ALUMINIUM
4	IMPELLER	TECHNOPOLYMER A
7	SHAFT WITH ROTOR	AISI 416 STAINLESS STEEL X12 CrS13 - UNI 6900/71
16	MECHANICAL SEAL	CARBON / CERAMIC
28	OR RING	NBR RUBBER
160	VENTURI DIFFUSER NOZZLE ASSEMBLY	TECHNOPOLYMER A

* In contact with the liquid

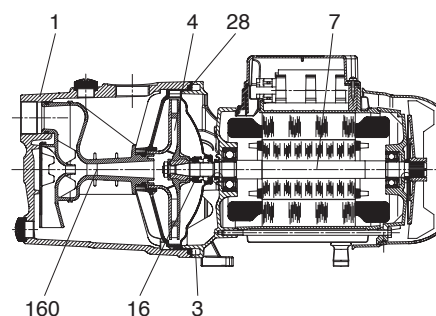

2 JET - CIVIL USE PRESSURE BOOSTER SETS

Pumped liquid temperature range: from 0°C to +35°C - Maximum ambient temperature: +40 °C - Max flow rate: 14.4 m³/h

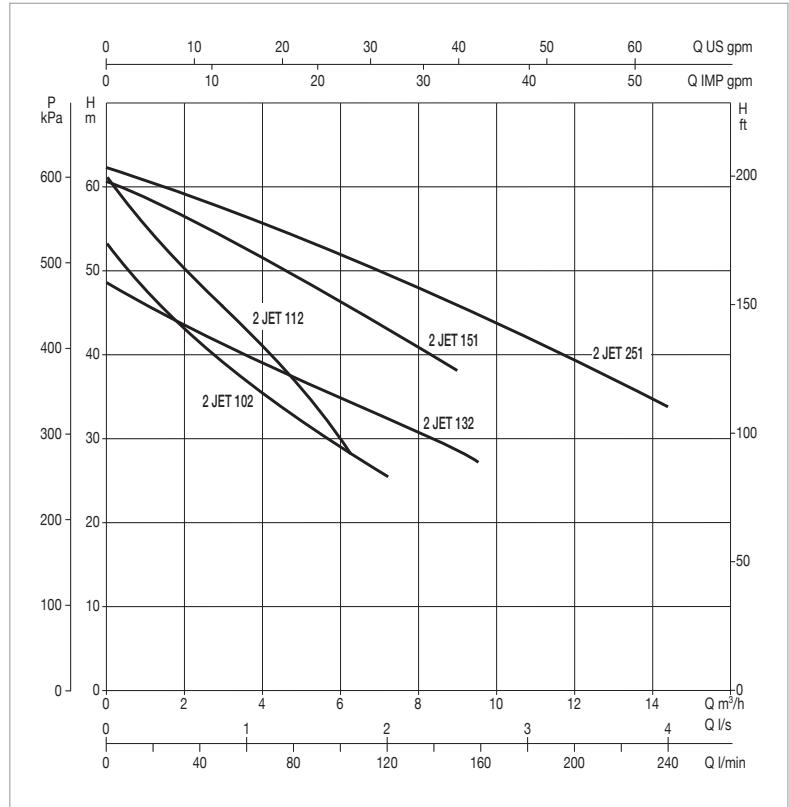
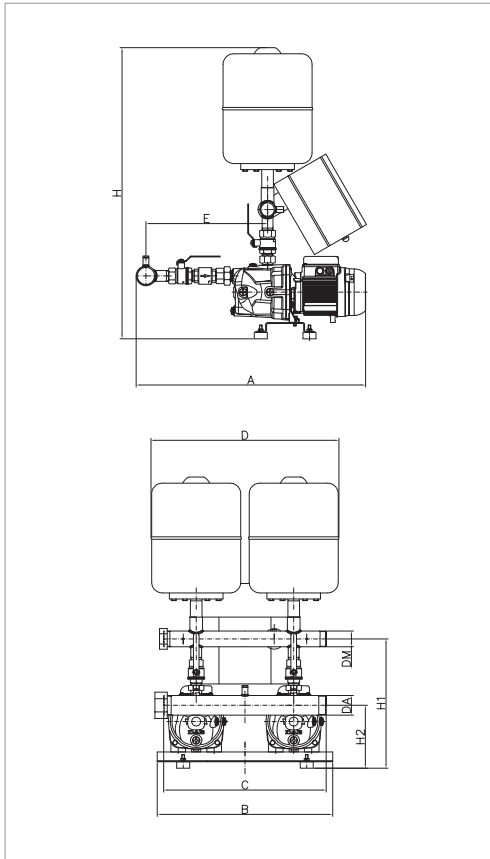

The performance curves are based on kinematic viscosity values = 1 mm²/s and density equal to 1000 kg/m³.
Curve tolerance according to ISO 9906.

MODEL	POWER INPUT 50 Hz	P2 NOMINAL		In A	FLOW m ³ /h	MAX OBTAINABLE PRESSURE BAR	STANDARD PRESSURE BAR
		kW	HP				
2 JET 102 M	1x220-240 V ~	2x0,75	2x1	2x5,1	6.6-3.0	5	3.5
2 JET 112 M	1x220-240 V ~	2x1	2x1,36	2x7	6.6-3.0	5.8	4
2 JET 132 M	1x220-240 V ~	2x1	2x1,36	2x7	9.6-3.0	4.6	3
2 JET 151 M	1x220-240 V ~	2x1,1	2x1,5	2x7,2	9.4-5.0	6.1	4
2 JET 251 M	1x220-240 V ~	2x1,85	2x2,5	2x10	14.0-7.2	6.4	4
2 JET 102 T	3x400 V ~	2x0,75	2x1	2x1,98	6.6-3.0	5	3.5
2 JET 112 T	3x400 V ~	2x1	2x1,36	2x2,7	6.6-3.0	5.8	4
2 JET 132 T	3x400 V ~	2x1	2x1,36	2x2,7	9.6-3.0	4.6	3
2 JET 151 T	3x400 V ~	2x1,1	2x1,5	2x3	9.4-5.0	6	4
2 JET 251 T	3x400 V ~	2x1,85	2x2,5	2x4	14.4-7.2	6	4

MODEL	A	B	C	D	E	H	H1	H2	Ø MANIFOLDS		WEIGHT kg
									DNA (suc.)	DNM (del.)	
2 JET 102 M	715	540	500	575	385	830	398	194	2"	1 1/2"	71
2 JET 112 M	715	540	500	575	385	830	398	194	2"	1 1/2"	74
2 JET 132 M	715	540	500	575	385	830	398	194	2"	1 1/2"	77
2 JET 151 M	715	540	500	565	385	830	398	194	2"	1 1/2"	101
2 JET 251 M	715	540	500	575	385	830	398	194	2"	1 1/2"	75
2 JET 102 T	715	540	500	575	385	830	398	194	2"	1 1/2"	75
2 JET 112 T	715	540	500	575	385	830	398	194	2"	1 1/2"	78
2 JET 132 T	715	540	500	575	385	830	398	194	2"	1 1/2"	81
2 JET 151 T	960	540	500	565	535	850	458	184	2"	1 1/2"	105
2 JET 251 T	960	540	500	565	535	850	458	184	2"	1 1/2"	108



E.BOX
PAGE 175



TECHNICAL DATA

Operating range: from 1 to 14.5 m³/h.

Pumped liquid: clean, free of solids and abrasives, non viscous, non aggressive, non crystallised and chemically neutral, with properties similar to water.

Pumped liquid temperature range: from 0 °C to +35 °C for domestic use - +40 °C for other uses.

Maximum ambient temperature: +40°C.

Maximum operating pressure: PN10.

Special executions on request: contact our sales network.

Protection class: IP44.

IE2 motors as standard from 0,75 kW to 5,5 kW - IE3 ≥ 7,5 kW.

APPLICATIONS

Water lifting sets particularly suited for domestic use, and small civil, agricultural, or industrial systems. Their main features are utmost reliability, simple operation, and the fact that no maintenance is required. The sets are supplied as standard with tanks and with air supply connector.

CONSTRUCTION FEATURES

HYDRAULIC SECTION

2 EURO multistage centrifugal electric pumps. Tropicalized galvanized sheet steel base complete with 4 rubber anti-vibration feet. Suction and delivery manifolds in tropicalized galvanized steel. 2 membrane tanks. Ball valves with unions on the suction and delivery ports of each pump. Check valves on the suction port of each pump. 1 1/4" air supply connection at the suction of each pump. 2 tropicalized galvanized cast iron female plugs for closing the manifolds. 1 pressure transmitter on the delivery manifold (pressure detection).

ELECTRICAL SECTION

Supplied in an IP 55 protection class self-extinguishing thermoplastic material box, the control panel protects the electric pumps from abnormal conditions such as: overload and overtemperature (with automatic reset), short circuit (with fuses - Plus model only), pump current surges (amperometric protection), abnormal voltage, dry run, quick starts, pressure sensor fault, or inconsistency of the external protection commands.

FRONT PANEL COMPONENTS:

General disconnecter with padlockable door lock. AUT-0-MAN operation selection pushbuttons. Alarm RESET pushbutton. Display for all models. Operation, stop, alarm notification lamps.

PANEL INTERNAL COMPONENTS:

Electronic control card with protection fuses and contactors. Power input connection terminal (single phase or three phase). Dry run or overpressure pressure switch connection terminals (optional). Alarm notification N.O. contacts. Function selection mini dip switch (pressure transmitter or pressure switches, standard or additional tanks).

The electric control panel is ready for the connection of:

Dry run protection float or pressure switch kit (*).

Overpressure stop pressure switch kit (*).

(* available separately as optional).

The sets are supplied in a sturdy cardboard packaging on wooden pallet and installation / maintenance manual with electric diagram.

MATERIALS

N.	PARTS*	MATERIALS
1	PUMP BODY	CAST IRON 200 UNI ISO 185
4	IMPELLER	TECHNOPOLYMER
6	DIFFUSER	TECHNOPOLYMER
7	SHAFT WITH ROTOR	AISI 304 STAINLESS STEEL X5CrNi 1810 UNI 6900/71
16	MECHANICAL SEAL	CARBON / CERAMIC
28	OR RING	NBR
36	SEAL COVER	AISI 304 STAINLESS STEEL X5CrNi 1810 UNI 6900/71
98	DIFFUSER BODY	TECHNOPOLYMER
304	REAR DISC	TECHNOPOLYMER

* In contact with the liquid

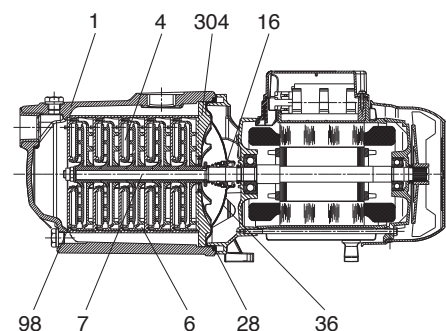

2 EURO - CIVIL USE PRESSURE BOOSTER SETS

Pumped liquid temperature range: from 0 °C to +35 °C for domestic use - from 0 °C to +40 °C for other uses.

Maximum ambient temperature: +40 °C - Max flow rate: 14.5 m³/h

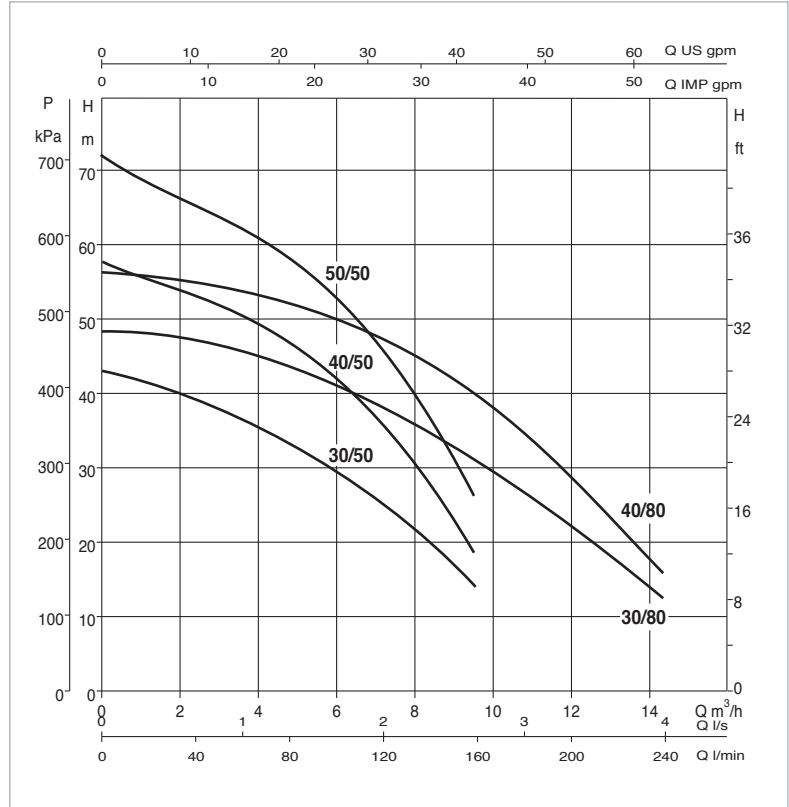
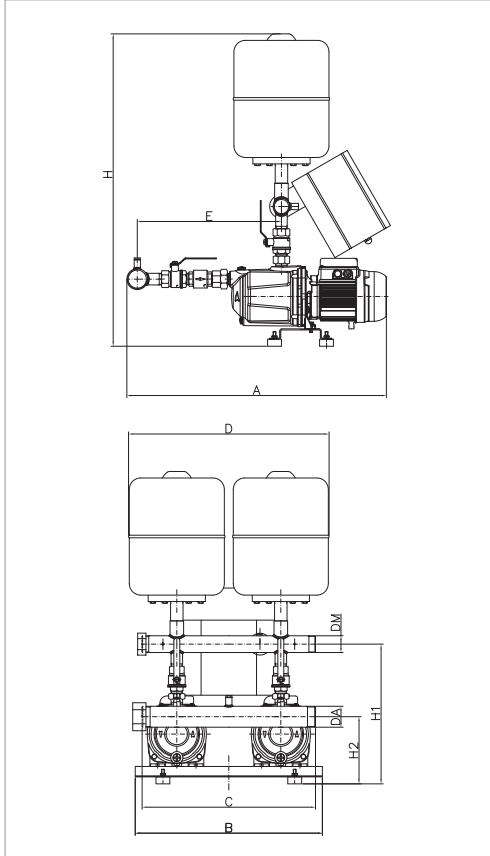

The performance curves are based on kinematic viscosity values = 1 mm²/s and density equal to 1000 kg/m³.
Curve tolerance according to ISO 9906.

MODEL	POWER INPUT 50 Hz	P2 NOMINAL		In A	FLOW m³/h	MAX OBTAINABLE PRESSURE BAR	STANDARD PRESSURE BAR
		kW	HP				
2 EURO 30/50 M	1x220-240 V~	2x0,55	2x0,75	2x3,9	8.0-4.4	3.8	2.5
2 EURO 40/50 M	1x220-240 V~	2x0,75	2x1	2x5,3	8.0-5.2	5.3	3.5
2 EURO 50/50 M	1x220-240 V~	2x1	2x1,36	2x6,3	7.6-5.2	6.5	4.5
2 EURO 30/80 M	1x220-240 V~	2x0,8	2x1,1	2x5,3	11.0-7.0	4.3	3
2 EURO 40/80 M	1x220-240 V~	2x1	2x1,36	2x6,3	10.0-6.0	5.5	4
2 EURO 30/50 T	3x400 V~	2x0,55	2x0,75	2x1,6	8.0-4.4	3.8	2.5
2 EURO 40/50 T	3x400 V~	2x0,75	2x1	2x2,2	8.0-5.2	5.3	3.5
2 EURO 50/50 T	3x400 V~	2x1	2x1,36	2x2,5	7.6-5.2	6.5	4.5
2 EURO 30/80 T	3x400 V~	2x0,8	2x1,1	2x2,2	11.0-7.0	4.3	3
2 EURO 40/80 T	3x400 V~	2x1	2x1,36	2x2,5	10.0-6.0	5.5	4

MODEL	A	B	C	D	E	H	H1	H2	Ø MANIFOLDS		WEIGHT kg
									DNA (suc.)	DNM (del.)	
2 EURO 30/50 M	755	540	500	578	415	830	402	194	2"	1"½	57
2 EURO 40/50 M	755	540	500	578	415	830	402	194	2"	1"½	57
2 EURO 50/50 M	755	540	500	578	415	830	402	194	2"	1"½	56
2 EURO 30/80 M	755	540	500	578	415	830	402	194	2"	1"½	57
2 EURO 40/80 M	755	540	500	578	415	830	402	194	2"	1"½	56
2 EURO 30/50 T	755	540	500	578	415	830	402	194	2"	1"½	57
2 EURO 40/50 T	755	540	500	578	415	830	402	194	2"	1"½	57
2 EURO 50/50 T	755	540	500	578	415	830	402	194	2"	1"½	58
2 EURO 30/80 T	755	540	500	578	415	830	402	194	2"	1"½	57
2 EURO 40/80 T	755	540	500	578	415	830	402	194	2"	1"½	58

2 EUROINOX

PRESSURE BOOSTER SETS WITH 2 HORIZONTAL MULTISTAGE SELF-PRIMING EUROINOX PUMPS

E.BOX
PAGE 175



TECHNICAL DATA

Operating range: from 1 to 14.5 m³/h

Pumped liquid: clean, free of solids and abrasives, non viscous, non aggressive, non crystallised and chemically neutral, with properties similar to water.

Pumped liquid temperature range: from 0 °C to +35 °C for domestic use - +40 °C for other uses

Maximum ambient temperature: +40°C

Maximum operating pressure: PN10

Special executions on request: contact our sales network

Protection class: IP44

IE2 motors as standard from 0,75 kW to 5,5 kW - IE3 ≥ 7,5 kW

APPLICATIONS

Water lifting sets particularly suited for domestic use, and small civil, agricultural, or industrial systems. The centrifugal multistage EUROINOX electric pumps used have the characteristics of also working when water, gas, or small amounts of sand are present in the water. These pumps are invaluable when drawing water from artesian wells and in case of suction difficulties. Their main features are utmost reliability, simple operation, and the fact that no maintenance is required. The sets are supplied as standard with tanks and with air supply connector.

CONSTRUCTION FEATURES

HYDRAULIC SECTION

2 EUROINOX multistage centrifugal electric pumps. Tropicalized galvanized sheet steel base complete with 4 rubber anti-vibration feet. Threaded suction and delivery manifolds in AISI 304 STAINLESS STEEL. 2 membrane tanks. Ball valves with unions on the suction and delivery ports of each pump. Check valves on the suction port of each pump. 1 1/4" air supply connection at the suction of each pump. 2 STAINLESS STEEL female plugs for closing the manifolds. 1 pressure transmitter on the delivery manifold (pressure detection).

ELECTRICAL SECTION

Supplied in an IP 55 protection class self-extinguishing thermoplastic material box, the control panel protects the electric pumps from abnormal conditions such as: overload and overtemperature (with automatic reset), short circuit (with fuses - Plus model only), pump current surges (amperometric protection), abnormal voltage, dry run, quick starts, pressure sensor fault, or inconsistency of the external protection commands.

FRONT PANEL COMPONENTS:

General disconnecter with padlockable door lock. AUT-O-MAN operation selection pushbuttons. Alarm RESET pushbutton. Display for all models. Operation, stop, alarm notification lamps.

PANEL INTERNAL COMPONENTS:

Electronic control card with protection fuses and contactors. Power input connection terminal (single phase or three phase). Dry run or overpressure pressure switch connection terminals (optional). Alarm notification N.O. contacts. Function selection mini dip switch (pressure transmitter or pressure switches, standard or additional tanks).

The electric control panel is ready for the connection of:

Dry run protection float or pressure switch kit (*).

Overpressure stop pressure switch kit (*).

(* available separately as optional.

The sets are supplied in a sturdy cardboard packaging on wooden pallet and installation / maintenance manual with electric diagram.

MATERIALS

N.	PARTS*	MATERIALS
1	PUMP BODY	AISI 304 STAINLESS STEEL X5CrNi 1810 UNI 6900/71
4	IMPELLER	TECHNOPOLYMER
6	DIFFUSER	TECHNOPOLYMER
7	SHAFT WITH ROTOR	AISI 304 STAINLESS STEEL X5CrNi 1810 UNI 6900/71
16	MECHANICAL SEAL	CARBON / CERAMIC
28	OR RING	NBR
36	SEAL COVER	AISI 304 STAINLESS STEEL X5CrNi 1810 UNI 6900/71
98	DIFFUSER BODY	TECHNOPOLYMER
304	REAR DISC	TECHNOPOLYMER
305	FRONT DISC	TECHNOPOLYMER

* In contact with the liquid

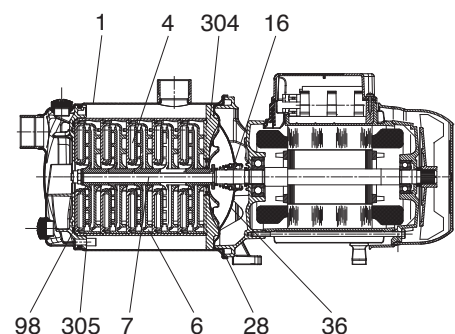

2 EUROINOX - CIVIL USE PRESSURE BOOSTER SETS

Pumped liquid temperature range: from 0 °C to +35 °C for domestic use - from 0 °C to +40 °C for other uses.

Maximum ambient temperature: +40 °C - Max flow rate: 14.5 m³/h

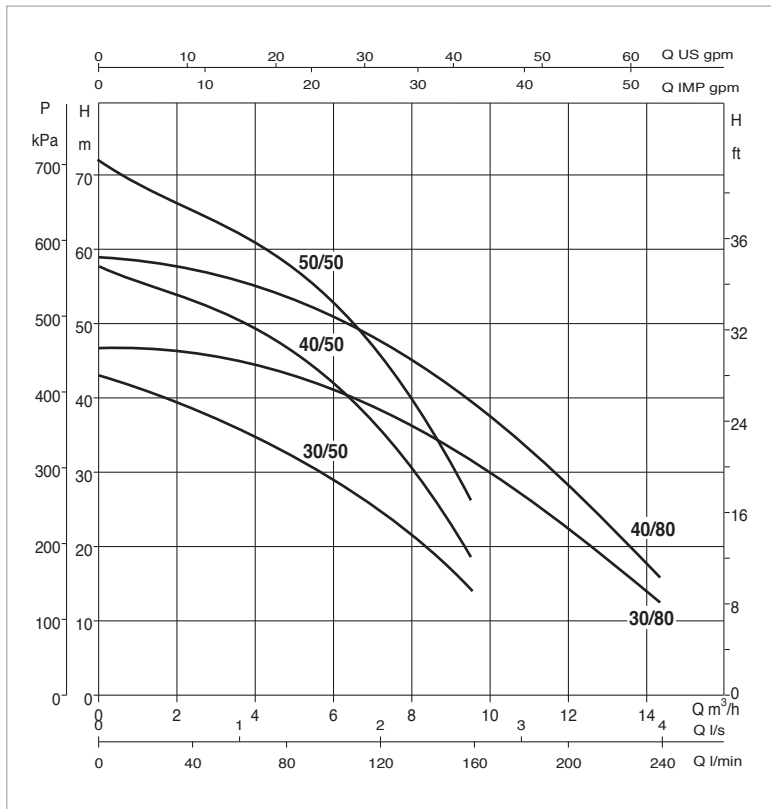
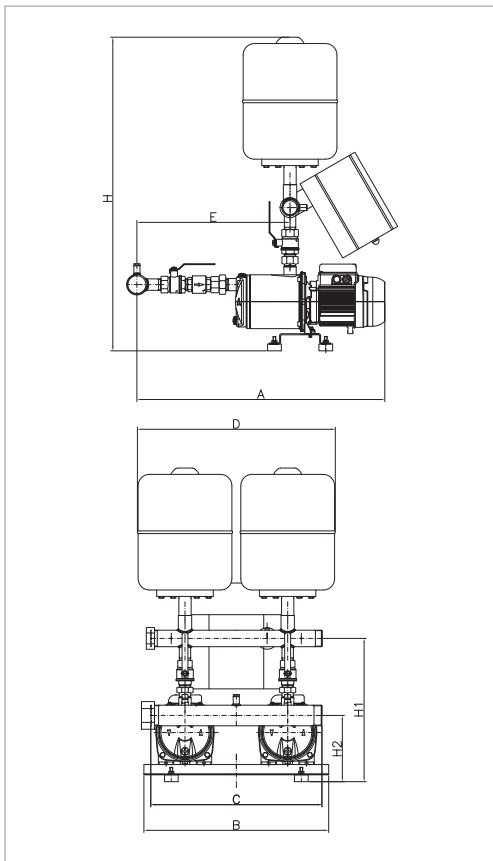

The performance curves are based on kinematic viscosity values = 1 mm²/s and density equivalent to 1000 kg/m³
Curve tolerance according to ISO 9906.

MODEL	POWER INPUT 50 Hz	P2 NOMINAL		In A	FLOW m ³ /h	MAX OBTAINABLE PRESSURE BAR	STANDARD PRESSURE BAR
		kW	HP				
2 EUROINOX 30/50 M	1x220-240 V~	2x0,55	2x0,75	2x3,9	8.0-4.4	3.8	2.5
2 EUROINOX 40/50 M	1x220-240 V~	2x0,75	2x1	2x5,3	8.0-5.2	5.3	3.5
2 EUROINOX 50/50 M	1x220-240 V~	2x1	2x1,36	2x6,3	7.6-5.2	6.5	4.5
2 EUROINOX 30/80 M	1x220-240 V~	2x0,8	2x1,1	2x5,3	11.0-7.0	4.3	3
2 EUROINOX 40/80 M	1x220-240 V~	2x1	2x1,36	2x6,3	10.0-6.0	5.5	4
2 EUROINOX 30/50 T	3x400 V~	2x0,55	2x0,75	2x1,6	8.0-4.4	3.8	2.5
2 EUROINOX 40/50 T	3x400 V~	2x0,75	2x1	2x2,2	8.0-5.2	5.3	3.5
2 EUROINOX 50/50 T	3x400 V~	2x1	2x1,36	2x2,5	7.6-5.2	6.5	4.5
2 EUROINOX 30/80 T	3x400 V~	2x0,8	2x1,1	2x2,2	11.0-7.0	4.3	3
2 EUROINOX 40/80 T	3x400 V~	2x1	2x1,36	2x2,5	10.0-6.0	5.5	4

MODEL	A	B	C	D	E	H	H1	H2	Ø MANIFOLDS		WEIGHT kg
									DNA (suc.)	DNM (del.)	
2 EUROINOX 30/50 M	760	540	500	578	450	830	420	194	2"	1 ¹ / ₂ "	57
2 EUROINOX 40/50 M	760	540	500	578	450	830	420	194	2"	1 ¹ / ₂ "	57
2 EUROINOX 50/50 M	760	540	500	578	450	830	420	194	2"	1 ¹ / ₂ "	57
2 EUROINOX 30/80 M	760	540	500	578	450	830	420	194	2"	1 ¹ / ₂ "	57
2 EUROINOX 40/80 M	760	540	500	578	450	830	420	194	2"	1 ¹ / ₂ "	57
2 EUROINOX 30/50 T	760	540	500	578	450	830	420	194	2"	1 ¹ / ₂ "	57
2 EUROINOX 40/50 T	760	540	500	578	450	830	420	194	2"	1 ¹ / ₂ "	57
2 EUROINOX 50/50 T	760	540	500	578	450	830	420	194	2"	1 ¹ / ₂ "	58
2 EUROINOX 30/80 T	760	540	500	578	450	830	420	194	2"	1 ¹ / ₂ "	57
2 EUROINOX 40/80 T	760	540	500	578	450	830	420	194	2"	1 ¹ / ₂ "	58



E.BOX
PAGE 175



TECHNICAL DATA

Operating range: from 1 to 19 m³/h.

Pumped liquid: clean, free of solids and abrasives, non viscous, non aggressive, non crystallised and chemically neutral, with properties similar to water.

Pumped liquid temperature range: from -10°C to +70°C.

Maximum ambient temperature: +40°C

Maximum operating pressure: PN10

Special executions on request: contact our sales network.

Protection class: IP44.

IE2 motors as standard from 0,75 kW to 5,5 kW - IE3 ≥ 7,5 kW.

APPLICATIONS

Water lifting sets particularly suited for small and medium civil systems. The use of K double impeller electric pumps ensures a high power-pressure ratio, resulting in high performance and extremely quiet operation. Their main features are construction sturdiness, compact sizes, and utmost reliability. The sets are supplied as standard with tanks and with air supply connector.

CONSTRUCTION FEATURES

HYDRAULIC SECTION

2 K double impeller centrifugal electric pumps. Tropicalized galvanized sheet steel base complete with 4 rubber anti-vibration feet. Suction and delivery manifolds in tropicalized galvanized steel. 2 membrane tanks. Ball valves with unions on the suction and delivery ports of each pump. Check valves on the suction port of each pump. 2 tropicalized galvanized cast iron female plugs for closing the manifolds. 1 1/4" air supply connection at the suction of each pump. 1 pressure transmitter on the delivery manifold (pressure detection).

ELECTRICAL SECTION

Supplied in an IP 55 protection class self-extinguishing thermoplastic material box, the control panel protects the electric pumps from abnormal conditions such as: overload and overtemperature (with automatic reset), short circuit (with fuses - Plus model only), pump current surges (amperometric protection), abnormal voltage, dry run, quick starts, pressure sensor fault, or inconsistency of the external protection commands.

FRONT PANEL COMPONENTS:

General disconnecter with padlockable door lock. AUT-0-MAN operation selection pushbuttons. Alarm RESET pushbutton. Display for all models. Operation, stop, alarm notification lamps.

PANEL INTERNAL COMPONENTS:

Electronic control card with protection fuses and contactors. Power input connection terminal (single phase or three phase).

Dry run or overpressure pressure switch connection terminals (optional). Alarm notification N.O. contacts. Function selection mini dip switch (pressure transmitter or pressure switches, standard or additional tanks).

The electric control panel is ready for the connection of:

Dry run protection float or pressure switch kit (*).

Overpressure stop pressure switch kit (*).

(* available separately as optional.

The sets are supplied in a sturdy cardboard packaging on wooden pallet and installation / maintenance manual with electric diagram.

MATERIALS

N.	PARTS	MATERIALS	MODELS
1	PUMP BODY	CAST IRON 200 UNI ISO 185	
3	SUPPORT	CAST IRON 200 UNI ISO 185	
4	IMPELLER	TECHNOPOLYMER A	K 35/40; K 45/50; K 55/100
		TECHNOPOLYMER B	K 55/50; K 66/100; K 90/100
7	SHAFT WITH ROTOR	AISI 416 STAINLESS STEEL X12CRS13 UNI 6900/71	K 35/40
		AISI 303 STAINLESS STEEL X10CRNIS 1089 UNI 6900/71	K 45/50; K 55/50; K 55/100; K66/100; K 90/100
16	MECHANICAL SEAL	CARBON / CERAMIC	
28	GASKET	NBR RUBBER	K 35/40; K 45/50; K 55/50
		GUARNITAL	K 66/100; K 90/100
34	INTERMEDIATE DISC	CAST IRON 200 UNI ISO 185	K 35/40; K 45/50; K 55/50; K 66/100; K 90/100;

* In contact with the liquid

K 35/40

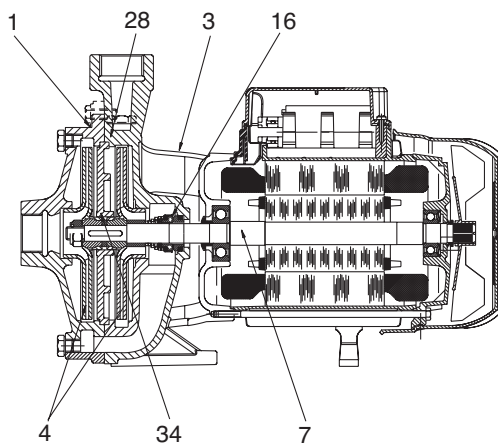

K 45/50 - K 55/50

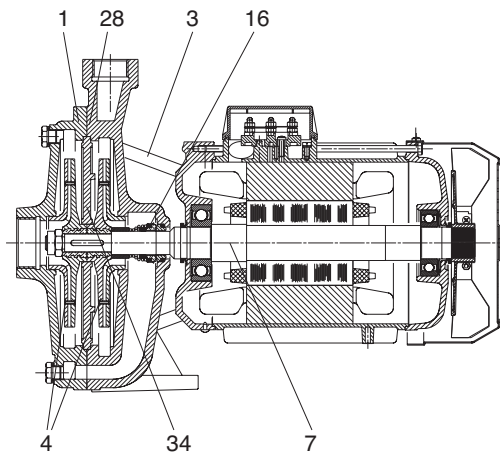

K 55/100 - K 66/100 - K 90/100

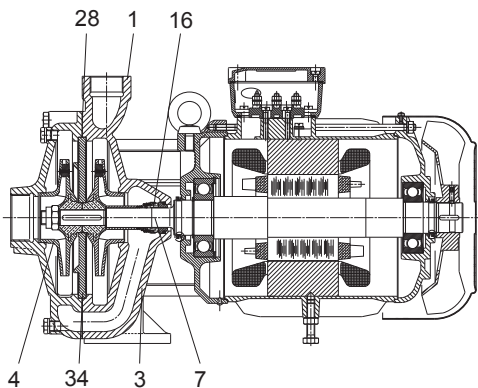

2K - CIVIL USE PRESSURE BOOSTER SETS

Pumped liquid temperature range: from -10 °C to +50 °C (K 35/40 - K 45/50 - K 55/100) / from -10 °C to +70 °C (K 55/50 - K 66/100 - K 90/100)

Maximum ambient temperature: +40 °C - Max flow rate: 19 m³/h

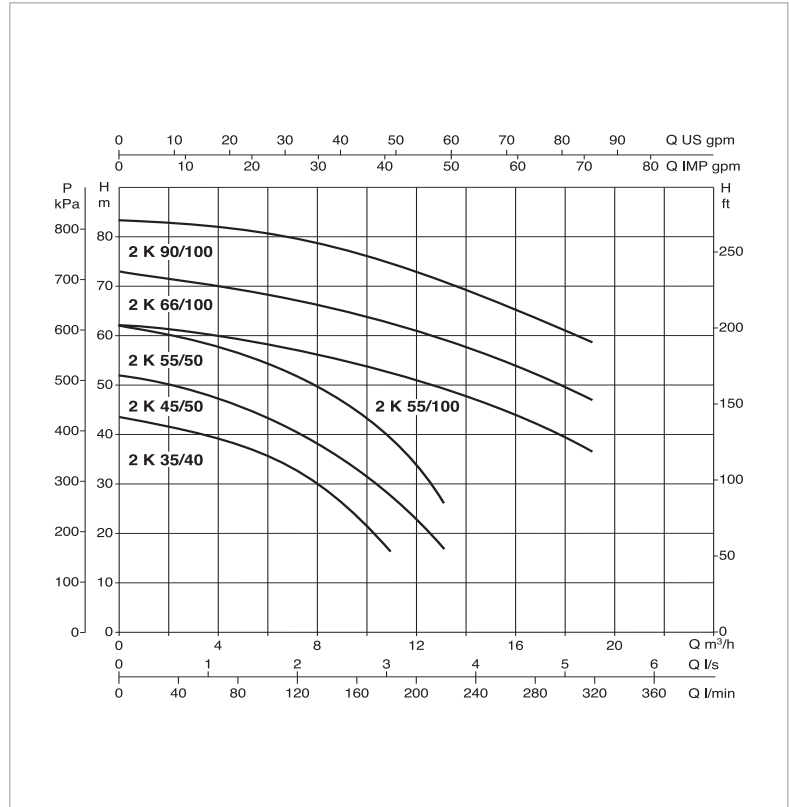
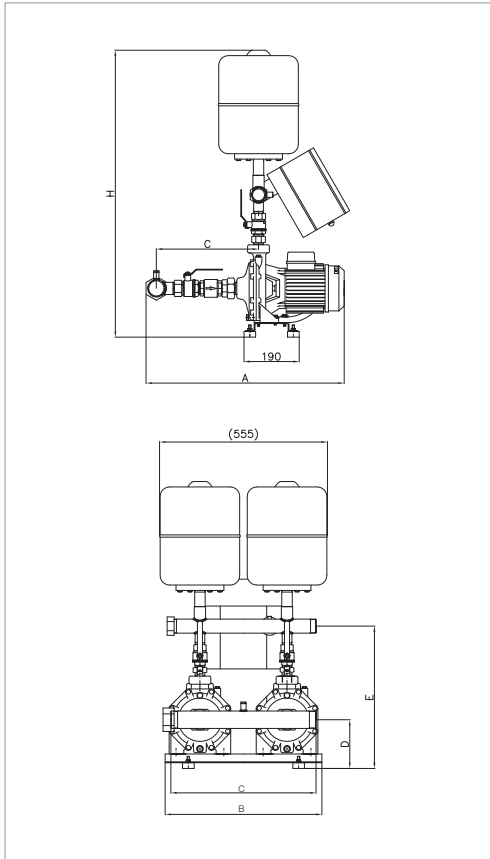

The performance curves are based on kinematic viscosity values = 1 mm²/s and density equivalent to 1000 kg/m³
Curve tolerance according to ISO 9906.

MODEL	POWER INPUT 50 Hz	P2 NOMINAL		In A	FLOW m³/h	MAX OBTAINABLE PRESSURE BAR	STANDARD PRESSURE BAR
		kW	HP				
2 K 35/40 M	1x220-240 V ~	2x0,75	2x1	2x5,5	9.0-6.0	4.2	2.5
2 K 45/50 M	1x220-240 V ~	2x1,1	2x1,5	2x8,3	10.8-6.0	5.2	3.5
2 K 55/50 M	1x220-240 V ~	2x1,85	2x2,5	2x12,8	12.0-7.0	6.2	4
2 K 35/40 T	3x400 V ~	2x0,75	2x1	2x3,5	9.6-6.0	4.2	2.5
2 K 45/50 T	3x400 V ~	2x1,1	2x1,5	2x3,6	10.8-6.0	5.2	3.5
2 K 55/50 T	3x400 V ~	2x1,85	2x2,5	2x4,8	12.0-7.0	6.2	4
2 K 55/100 T	3x400 V ~	2x2,2	2x3	2x6,7	18.0-10.0	6.2	4
2 K 66/100 T	3x400 V ~	2x3	2x4	2x8,4	18.0-10.0	7.3	5
2 K 90/100 T	3x400 V ~	2x4	2x5,5	2x9,7	21.0-14.0	8.4	6

MODEL	A	B	C	D	E	H	H1	H2	Ø MANIFOLDS		WEIGHT kg
									DNA (suc.)	DNM (del.)	
2 K 35/40 M	700	540	500	555	400	910	457	150	2"	1 1/2"	69
2 K 45/50 M	700	540	500	555	400	910	480	205	2"	1 1/2"	85
2 K 55/50 M	700	540	500	555	400	910	480	205	2"	1 1/2"	92
2 K 35/40 T	700	540	500	555	400	910	457	150	2"	1 1/2"	73
2 K 45/50 T	700	540	500	555	400	910	480	205	2"	1 1/2"	89
2 K 55/50 T	700	540	500	555	400	910	480	205	2"	1 1/2"	92
2 K 55/100 T	900	580	500	545	400	1120	570	220	2 1/2"	2 1/2"	155
2 K 66/100 T	900	580	500	545	400	1120	570	220	2 1/2"	2 1/2"	160
2 K 90/100 T	900	580	500	545	400	1120	570	220	2 1/2"	2 1/2"	167

AQUATWIN TOP

RAIN WATER RECOVERY SYSTEM PRESSURE BOOSTER SETS



TECHNICAL DATA

Line voltage: 230 V single phase.
Voltage of electric pump: 230 V single phase.
Power frequency: 50 Hz.
Installation: vertical only.
Pumped liquid temperature range: from 0 °C to +40 °C.
Maximum ambient temperature: 40 °C.
Max pressure: 5,5bar.
Pumped liquid: clean, free from solids.
Pressure regulation range: 3 to 5 bar.
Suction diameter (DNA): 1"
Delivery diameter (DNM): 1"1/2
Protection class: IP44.
IE2 motors as standard from 0,75 kW to 5,5 kW - IE3 \geq 7,5 kW.

APPLICATIONS

The AQUATWIN TOP sets have been designed and produced to meet the needs of the modern engineering solutions of rain water recycling systems, with consequent saving of drinking water.

They are suited to medium to large applications, such as schools, healthcare establishments, hospitals, apartment complexes, hotels, gyms, shopping centres, for all uses where drinking water is not required for toilet flushing, floor washing, irrigation, car washing, etc.

AQUATWIN TOP characteristic features are versatility of use, silent operation, reliable operation, compact and stable structure.

CONSTRUCTION FEATURES

AQUATWIN TOP has a sturdy metal sheet structure, with black cataphoresis paint coating. In addition to better protection from corrosion and aggressive agents, this solution offers an aesthetically pleasing and captivating look. The structure very efficiently contains the pump set in the bottom section, the control panel on the side, and at the top a 150 litre water reservoir, which guarantees continuity of the supply also in case of lack of rain water. The adjustable base feet ensure stability also on irregular surfaces.

ADVANTAGES IN THE USE OF QUATWIN TOP AND RAIN WATER RECOVERY

The rain water recovery system has the objective to reuse rain water as an alternative to water from the public water network.

The rain water, stored in appropriate tanks, can be used to supply all those services that do not need drinking water (washing machine, WC, etc.).

Water savings are therefore guaranteed. It is calculated that in domestic application the daily water requirement per person is 150 litres.

This is particularly due to the use of the WC flushing system, cleaning activities, washing machine, garden irrigation, car washing, etc.

Approximately 50% of this water consumption can be met with rain water.

The use of rain water offers economic savings, in line with water savings, and therefore of 50%.

In addition to water and economic savings, the reuse of rain water offers other advantages due to its chemical composition.

Rain water has a limited lime content.

This results in softer water, with advantages for the system:

- limited presence of lime scale in the piping system.
- limited amount of lime residuals.
- detergent savings, and therefore less pollution for the environment.

AQUATWIN TOP

RAIN WATER RECOVERY SYSTEM PRESSURE BOOSTER SETS

HYDRAULIC SECTION

The hydraulic structure of AQUATWIN TOP is split in several sections.

The pumping section, similar to a standard domestic pressure booster set consisting of:

A	CONNECTION TO THE RAIN WATER TANK - THROUGH THREE-WAY SOLENOID VALVES
B	CONNECTION TO THE 150 L TANK - PUBLIC WATER MAINS
C	STAINLESS STEEL DELIVERY MANIFOLD, WITH POSSIBILITY OF CONNECTION ON BOTH SIDES
D	8 LITRE EXPANSION VESSEL
AND	PRESSURE SENSOR
F	MANOMETER
G	JETINOX OR EUROINOX PUMPS

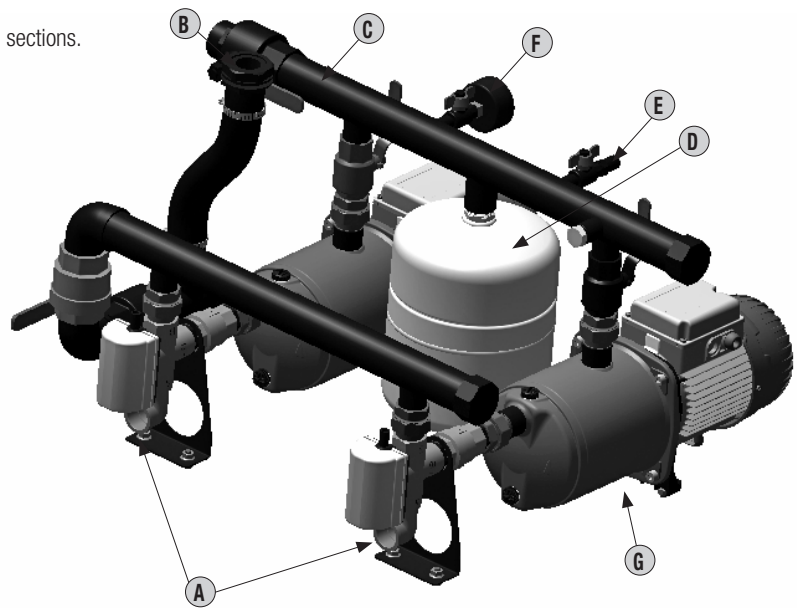

And of a section for automatic refilling of the 150 litre water reservoir with drinking water, using a so-called "AIR GAP" system, which complies with UNI EN 1717: Protection against pollution of potable water in water installations and general requirements of devices to prevent pollution by backflow.

AQUATWIN complies with this standard thanks to the "AIR GAP" system, which consists in an air gap that prevents contact between water from the public water network and rain water, meeting the safety distance requirements between the point of supply and the maximum tank level (overflow limit "H").

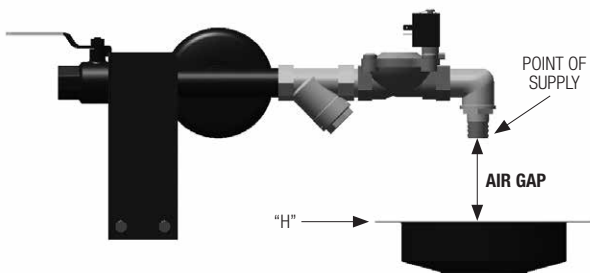

HYDRAULIC CONNECTIONS	
L	SUPPLY FROM THE PUBLIC NETWORK
M	OVERFLOW OUTLET
N	CONNECTION TO THE USERS (REVERSIBLE)
P	CONNECTION TO THE RAIN WATER TANK

The suction contact may be single or double, in case of two separate rain water tanks.

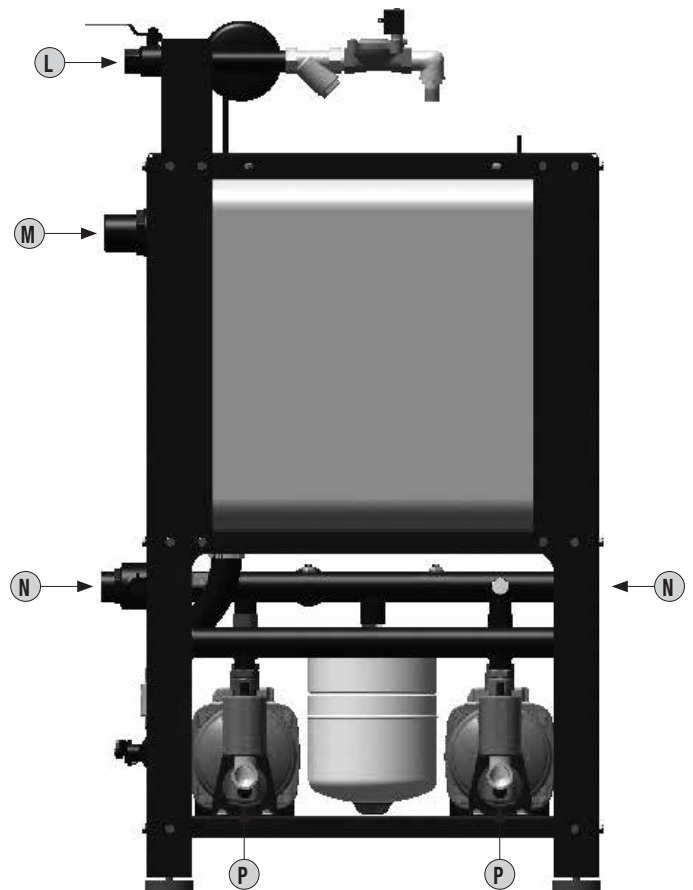

AQUATWIN TOP

RAIN WATER RECOVERY SYSTEM PRESSURE BOOSTER SETS

ELECTRICAL SECTION

IP 55 protection class self-extinguishing, shock-resistant plastic electric control panel on the on the front section.

The control panel protects the electric pumps with an amperometric protection against dry run and controls the operating sequence, keeping the system at an average pressure value already preset at the factory.

The average pressure value may be changed using a trimmer found inside the control panel (SP).

The pump starting order is switched at each operating cycle.

A dedicated electronic card manages the rain water tank levels (**AQUATWIN TOP can handle one or two independent first collection tanks**), controlling the two rain water/public water network switching solenoid valves and the refilling of the 150 litre tank to ensure service continuity.

Front panel components:

- General disconnecter with padlockable door lock.
- AUT - 0 - MAN function selection pushbuttons.
- Alarm RESET pushbutton.
- Operation, stop, alarm notification lamps.
- Overflow alarm buzzer.
- System monitoring graphic display.



Some additional connections are possible in the E-Nox card, including:

- Dry run or overpressure pressure switch connection terminals (optional).
- Alarm notification clean contacts (voltage free).



CONTROL PANEL COMPONENTS	
Q	DEDICATED ELECTRONIC CONTROL UNIT FOR THE MANAGEMENT OF THE SYSTEM
R	PROTECTION FUSES
S	E-BOX CARD
T	FLOAT CONNECTION TERMINAL BOX
V	PUMP CONNECTION

The sets are supplied in a sturdy cardboard packaging on wooden pallet and instruction leaflet with electric diagram.

AQUATWIN TOP 132 - RAIN WATER RECOVERY SYSTEM PRESSURE BOOSTER SET

Pumped liquid temperature range: from 0 °C to +40 °C - Maximum ambient temperature: +40 °C - Max flow rate: 9.6 m³/h

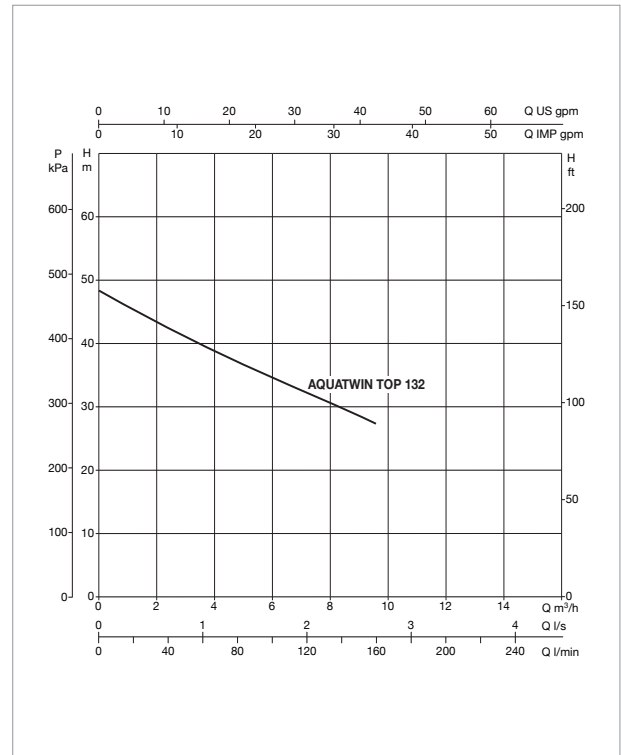
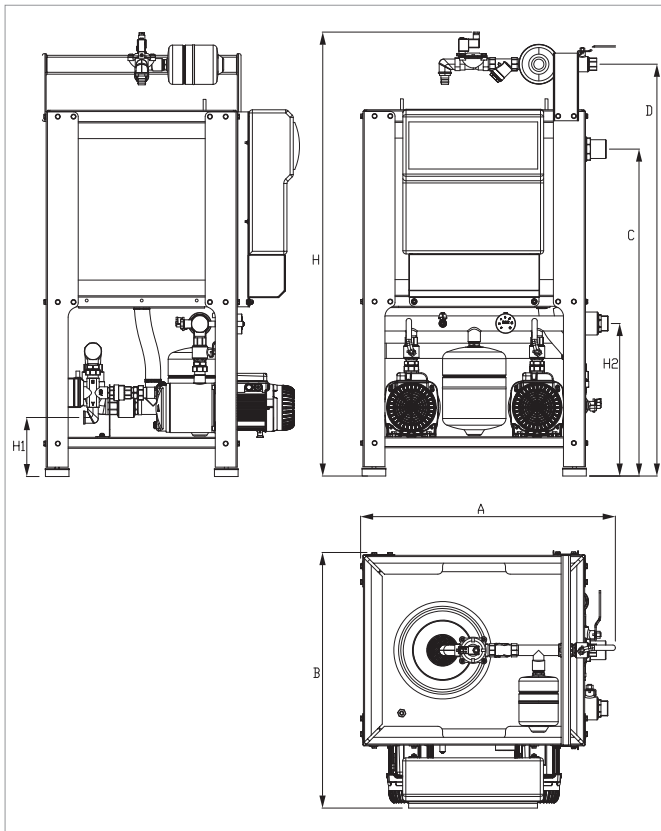

The performance curves are based on kinematic viscosity values = 1 mm²/s and density equal to 1000 kg/m³. Curve tolerance according to ISO 9906.
Overall performance taking into account TWO pumps working at the same time.

MODEL	ELECTRICAL DATA			HYDRAULIC DATA	
	50 Hz POWER INPUT	P2 NOMINAL		Q m³/h	H m
		kW X 2	HP X 2		
AQUATWIN TOP 132	1 X 230 V ~	1	1.36	0,6-9,6	47,5-27,5

MODEL	H1	H2	A	B	H	C	D	PACKING DIMENSIONS	DNA	DNM	WEIGHT kg
AQUATWIN TOP 132	188	485	810	815	1415	1040	1310	900x1100x2200	1" + 1"	1" 1/2	113

AQUATWIN TOP 40/50 - RAIN WATER RECOVERY SYSTEM PRESSURE BOOSTER SETS

Pumped liquid temperature range: from 0 °C to +40 °C - Maximum ambient temperature: +40 °C - Max flow rate: 9.6 m³/h

PRESSURE SETS

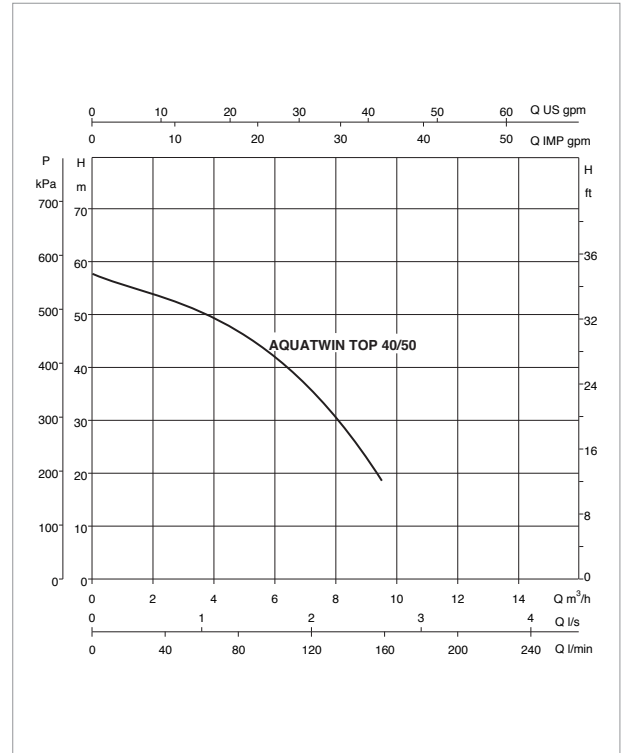
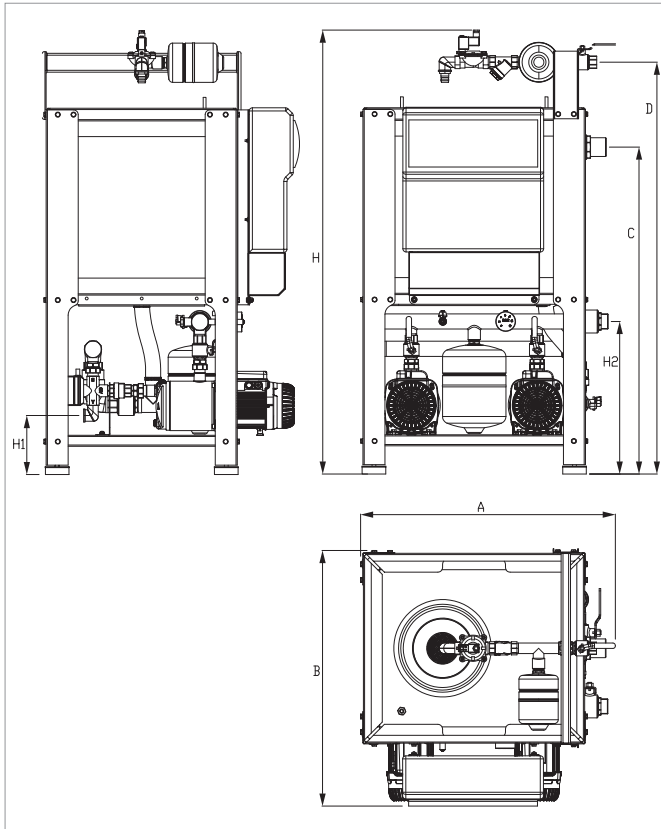

The performance curves are based on kinematic viscosity values = 1 mm²/s and density equal to 1000 kg/m³. Curve tolerance according to ISO 9906.
Overall performance taking into account TWO pumps working at the same time.

MODEL	ELECTRICAL DATA			HYDRAULIC DATA	
	50 Hz POWER INPUT	P2 NOMINAL		Q m³/h	H m
		kW X 2	HP X 2		
AQUATWIN TOP 40/50	1 X 230 V ~	0.75	1	0,6-9,6	57,6-19

MODEL	H1	H2	A	B	H	C	D	PACKING DIMENSIONS	DNA	DNM	WEIGHT kg
AQUATWIN TOP 40/50	188	485	810	815	1415	1040	1310	900x1100x2200	1" + 1"	1" 1/2	113

AQUATWIN TOP 40/80 - RAIN WATER RECOVERY SYSTEM PRESSURE BOOSTER SET

Pumped liquid temperature range: from 0 °C to +40°C - Maximum ambient temperature: +40 °C - Max flow rate: 14.4 m³/h

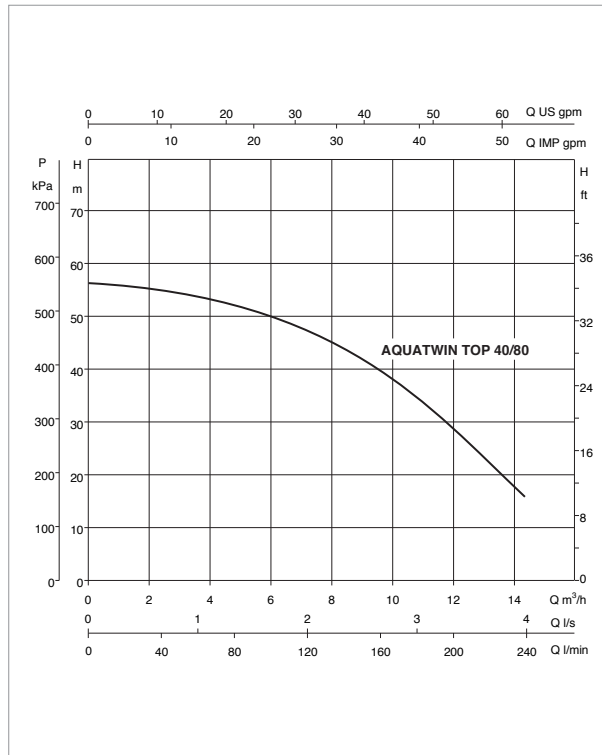
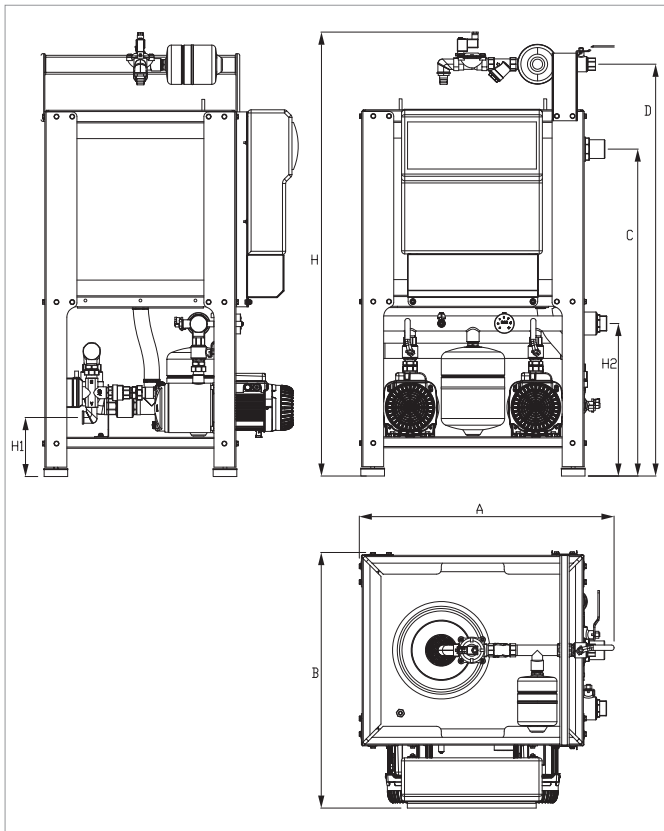

The performance curves are based on kinematic viscosity values = 1 mm²/s and density equal to 1000 kg/m³. Curve tolerance according to ISO 9906.
Overall performance taking into account TWO pumps working at the same time.

MODEL	ELECTRICAL DATA			HYDRAULIC DATA	
	50 Hz POWER INPUT	P2 NOMINAL		Q m³/h	H m
		kW X 2	HP X 2		
AQUATWIN TOP 40/80	1 X 230 V ~	1	1.36	0,6-14,2	59-16,5

MODEL	H1	H2	A	B	H	C	D	PACKING DIMENSIONS	DNA	DNM	WEIGHT kg
AQUATWIN TOP 40/80	188	485	810	815	1415	1040	1310	900x1100x2200	1" + 1"	1" 1/2	115

1-2-3 KVC

PRESSURE BOOSTER SETS WITH 1 - 2 - 3 VERTICAL AXIS MULTISTAGE CENTRIFUGAL PUMPS



**E.BOX
PAG 175**

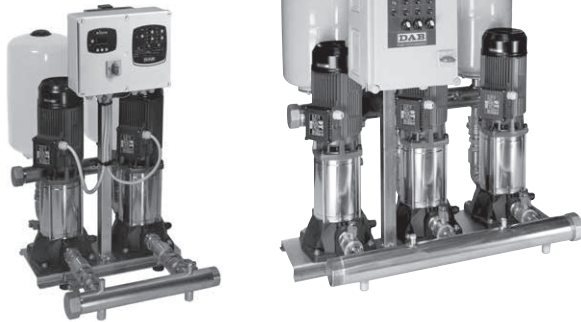

TECHNICAL DATA

Operating range: from 1 to 36 m³/h.

Pumped liquid: clean, free of solids and abrasives, non viscous, non aggressive, non crystallised and chemically neutral, with properties similar to water.

Pumped liquid temperature range: from 0 °C to +50 °C

Maximum ambient temperature: +40 °C.

Maximum operating pressure: PN16.

Special executions on request: contact our sales network.

Protection class: IP44.

IE2 motors as standard from 0,75 kW to 5,5 kW - IE3 ≥ 7,5 kW.

APPLICATIONS

Water lifting sets particularly suited for domestic use, and small civil, agricultural, or industrial systems. The use of vertical axis multistage centrifugal electric pumps ensures high performance results. Their main features are limited space requirements, sturdiness, absolute reliability, and extremely quiet operation.

CONSTRUCTION FEATURES

HYDRAULIC SECTION

1 - 2 - 3 KVC vertical axis multistage electric pump; galvanised steel metal sheet base; AISI 304 STAINLESS STEEL suction and delivery manifold (1 KVC without suction manifold); 1 - 2 - 3 membrane tanks; ball valves with unions at the suction and the delivery of each pump; check valve with unions at the suction of each pump; 1 1/4" are supply connections at the suction of each pump; 2 stainless steel female plugs for closing the manifolds; axial gauge with isolator valve; galvanised steel electric control panel support.

ELECTRICAL SECTION

1 KVC SET

Single phase version. 1 2-pole pressure switch connected to the electric pump, with power input plug.

Three phase version. Remote motor protector control panel with reset pushbutton, 1 2-pole pressure switch connected to the electric pump.

2 KVC SET

Supplied in an IP 55 protection class self-extinguishing thermoplastic material box, the control panel protects the electric pumps from abnormal conditions such as: overload and overtemperature (with automatic reset), short circuit (with fuses - Plus model only), pump current surges (amperometric protection), abnormal voltage, dry run, quick starts, pressure sensor fault, or inconsistency of the external protection commands.

FRONT PANEL COMPONENTS:

General disconnecter with padlockable door lock. AUT-O-MAN operation selection pushbuttons. Alarm RESET pushbutton. Display for all models. Operation, stop, alarm notification lamps.

PANEL INTERNAL COMPONENTS:

Electronic control card with protection fuses and contactors. Power input connection terminal (single phase or three phase).

Dry run or overpressure pressure switch connection terminals (optional). Alarm notification N.O. contacts. Function selection mini dip switch (pressure transmitter or pressure switches, standard or additional tanks).

3 KVC SET

IP 55 protection class self-extinguishing, shock-resistant plastic electric control panel. The control panel includes the general switch, the electric pump protection thermal magnetic circuit breakers, the electric pump start order switch system, 24 V low voltage circuit for the control of the pressure switches, MAN-O-AUT selectors. (Operation pushbuttons for single phase control panel), notification lamps at the front of the panel. Installed on appropriate support on the pump base. Three pump start/stop pre-calibrated pressure switches.

The electric control panel of 2 KVC and 3 KVC sets is ready for the connection of:

Dry run protection float or pressure switch kit (*).

Overpressure stop pressure switch kit (*).

(* available separately as optional.

The sets are supplied in a sturdy cardboard packaging on wooden pallet and installation / maintenance manual with electric diagram.

MATERIALS

N.	PARTS*	MATERIALS
1	PUMP BODY	TECHNOPOLYMER A
4	IMPELLER	TECHNOPOLYMER B
6	DIFFUSER	TECHNOPOLYMER B
7	SHAFT WITH ROTOR	AISI 303 STAINLESS STEEL X10 CrNi 1089 UNI 6900/71
16	MECHANICAL SEAL	SILICON CARBIDE/SILICON
28	OR RING	EPDM RUBBER
36	SEAL HOLDING DISC	AISI 304 STAINLESS STEEL X5 CrNi 1810 UNI 6900/71

N.	PARTS*	MATERIALS
57a	INTERMEDIATE STAGE	TECHNOPOLYMER B
69	LINER	AISI 304 STAINLESS STEEL X5 CrNi 1810 UNI 6900/71
98	DIFFUSER BODY	TECHNOPOLYMER B
271	CENTERING BUSHING	BRONZE B14
304	CONVEYOR	TECHNOPOLYMER B
8	DNM (standard for KVcx only)	

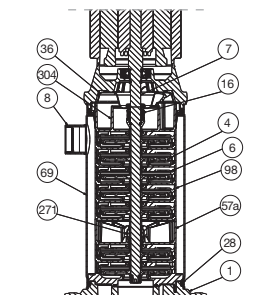

* In contact with the liquid.

1 KVC 50 - CIVIL USE PRESSURE BOOSTER SETS

Pumped liquid temperature range: from -10 °C to +50 °C - Maximum ambient temperature: +40 °C

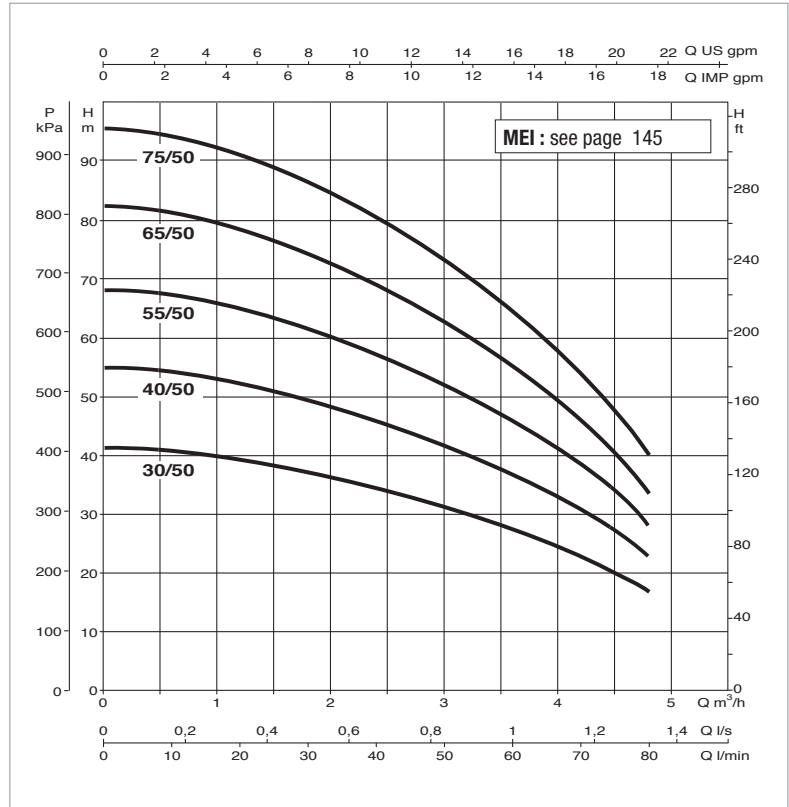
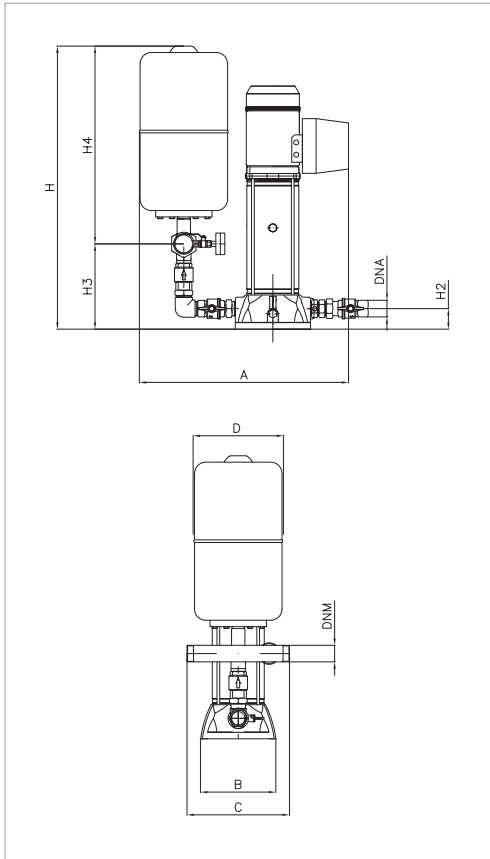

The performance curves are based on kinematic viscosity values = 1 mm²/s and density equivalent to 1000 kg/m³
Curve tolerance according to ISO 9906.

MODEL	POWER INPUT 50 Hz	P2 NOMINAL		In A	FLOW m ³ /h	MAX OBTAINABLE PRESSURE BAR	PRESSURE SWITCH CALIBRATION BAR
		kW	HP				
1 KVC 30/50 M 1x	220-240 v	0.55	0.75	4	4,5 - 1	4	2,5 - 3,5
1 KVC 30/50 T	3x 400 v	0.55	0.75	1.4	4,5 - 1	4	2,5 - 3,5
1 KVC 40/50 M 1x	220-240 v	0.8	1.1	5.6	4,5 - 1	5.2	4 - 5
1 KVC 40/50 T	3x 400 v	0.8	1.1	2.2	4,5 - 1	5.2	4 - 5
1 KVC 55/50 M 1x	220-240 v	1	1.36	6.4	4,5 - 1	6.5	5 - 6
1 KVC 55/50 T	3x 400 v	1	1.36	2.6	4,5 - 1	6.5	5 - 6
1 KVC 65/50 M 1x	220-240 v	1.1	1.5	7.4	4,5 - 1	8	6,5 - 7,5
1 KVC 65/50 T	3x 400 v	1.1	1.5	3.1	4,5 - 1	8	6,5 - 7,5
1 KVC 75/50 M 1x	220-240 v	1.5	2	9	4,5 - 1	9	7,5 - 8,5
1 KVC 75/50 T	3x 400 v	1.5	2	3.6	4,5 - 1	9	7,5 - 8,5

MODEL	A	B	C	D	H	H2	H3	H4	Ø MANIFOLDS		WEIGHT kg	
									DNA (suc.)	DNM (del.)	Single-phase	three-phase
1KVC 30/50	630	300	300	260	730	60	290	450	1" 1/4	1" 1/2	26	26
1KVC 40/50	630	300	300	260	730	60	290	450	1" 1/4	1" 1/2	28	28
1KVC 55/50	630	300	300	260	730	60	290	450	1" 1/4	1" 1/2	29	29
1KVC 65/50	630	300	300	260	730	60	290	450	1" 1/4	1" 1/2	32	32
1KVC 75/50	630	300	300	260	730	60	290	450	1" 1/4	1" 1/2	33	32

1 KVC 80 - CIVIL USE PRESSURE BOOSTER SETS

Pumped liquid temperature range: from -10 °C to +50 °C - Maximum ambient temperature: +40 °C

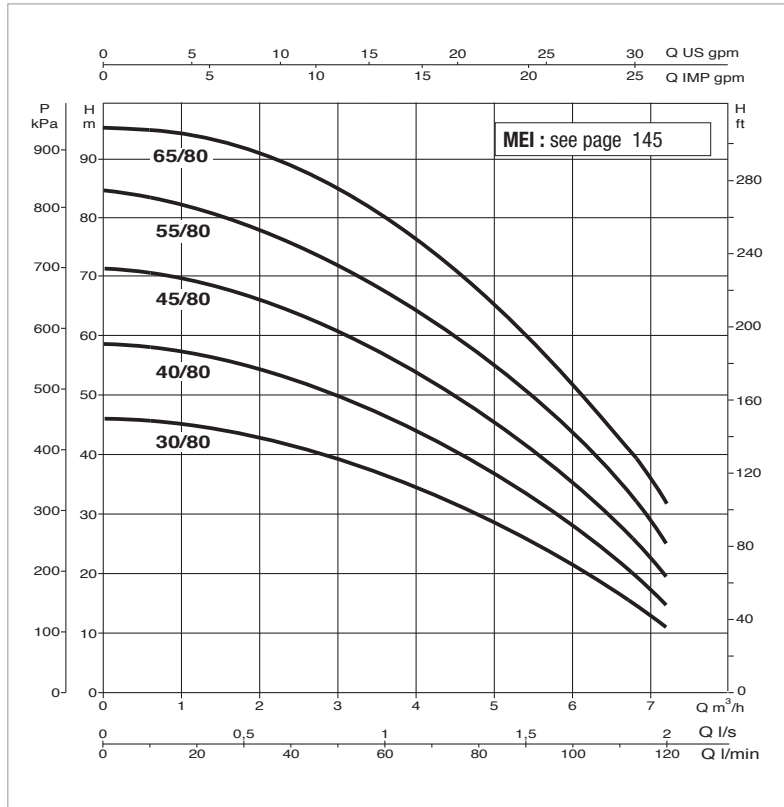
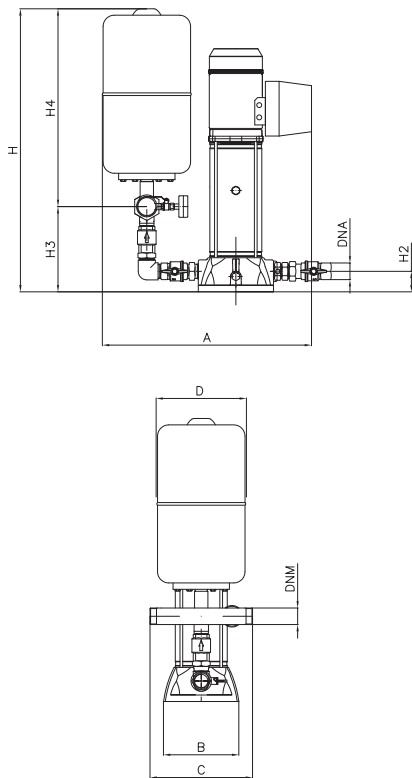

The performance curves are based on kinematic viscosity values = 1 mm²/s and density equivalent to 1000 kg/m³
Curve tolerance according to ISO 9906.

MODEL	POWER INPUT 50 Hz	P2 NOMINAL		In A	FLOW m ³ /h	MAX OBTAINABLE PRESSURE BAR	PRESSURE SWITCH CALIBRATION BAR
		kW	HP				
1 KVC 30/80 M	1x 220-240 v	0.8	1.1	5.6	7-2	4.5	3-4
1 KVC 30/80 T	3x 400 v	0.8	1.1	2.2	7-2	4.5	3-4
1 KVC 40/80 M	1x 220-240 v 1	1.36	6.5	7-2	5.5	4-5	4-5
1 KVC 40/80 T	3x 400 v	1	1.36	2.6	7-2	5.5	4-5
1 KVC 45/80 M	1x 220-240 v 1.1	1.5	7.4	7-2	6.8	5-6	2.5-3.5
1 KVC 45/80 T	3x 400 v	1.1	1.5	3.1	7-2	6.8	5-6
1 KVC 55/80 M	1x 220-240 v 1.5	2	9	7-2	8	6-7	4-5
1 KVC 55/80 T	3x 400 v	1.5	2	3.6	7-2	8	6-7
1 KVC 65/80 T	3x 400 v	2.2	3	4	7-2	9.2	7-8

MODEL	A	B	C	D	H	H2	H3	H4	Ø MANIFOLDS		WEIGHT kg	
									DNA (suc.)	DNM (del.)	Single-phase	Three-phase
1KVC 30/80	620	300	300	260	730	60	290	450	1" 1/4	1" 1/2	28	27
1KVC 40/80	620	300	300	260	730	60	290	450	1" 1/4	1" 1/2	29	29
1KVC 45/80	620	300	300	260	730	60	290	450	1" 1/4	1" 1/2	32	32
1KVC 55/80	620	300	300	260	730	60	290	450	1" 1/4	1" 1/2	33	32
1KVC 65/80	620	300	300	260	730	60	290	450	1" 1/4	1" 1/2	-	34

1 KVC 120 - CIVIL USE PRESSURE BOOSTER SETS

Pumped liquid temperature range: from -10 °C to +50 °C - Maximum ambient temperature: +40 °C

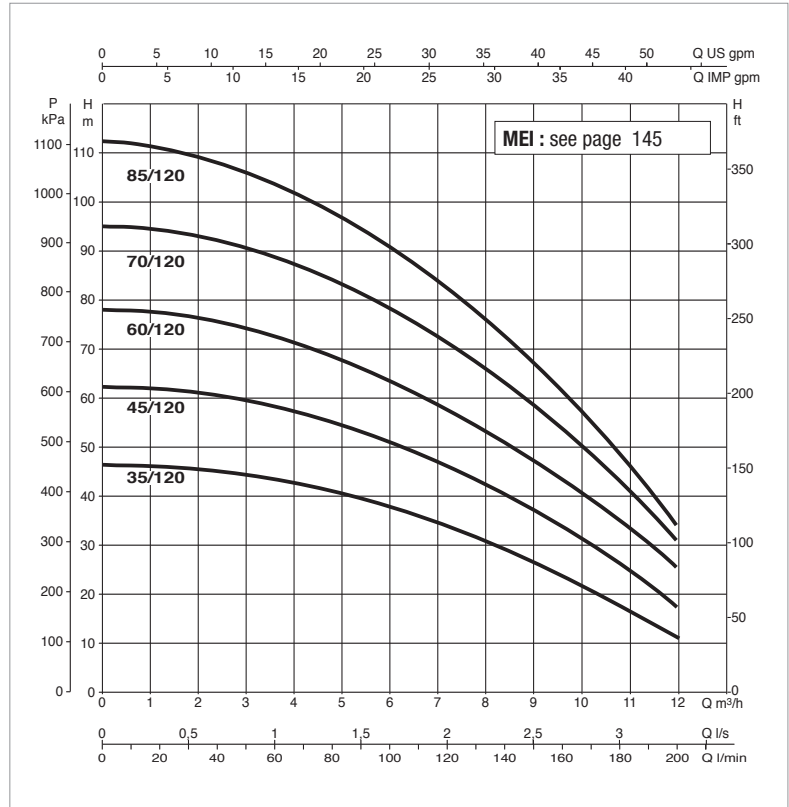
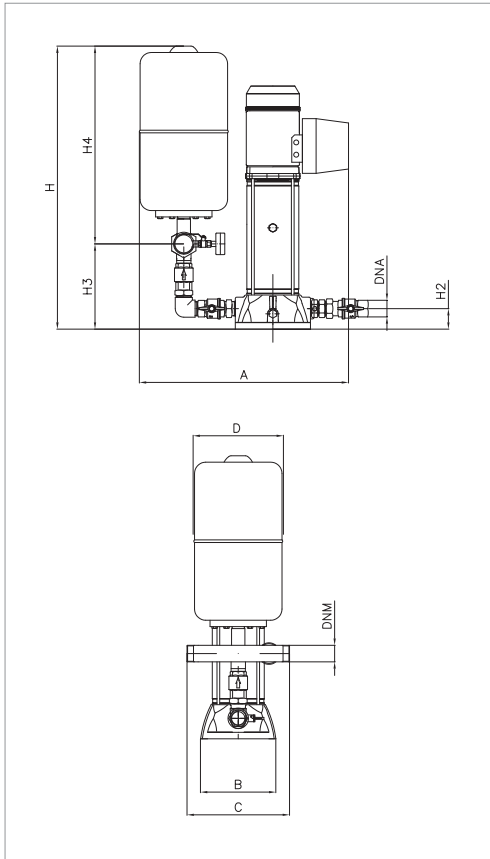

The performance curves are based on kinematic viscosity values = 1 mm²/s and density equivalent to 1000 kg/m³
Curve tolerance according to ISO 9906.

MODEL	POWER INPUT 50 Hz	P2 NOMINAL		In A	FLOW m ³ /h	MAX OBTAINABLE PRESSURE BAR	PRESSURE SWITCH CALIBRATION BAR
		kW	HP				
1 KVC 35/120 M	1x 220-240 v	1.1	1.5	7.4	11 - 2	4.5	3 - 4
1 KVC 35/120 T	3x 400 v	1.1	1.5	3.5	11 - 2	4.5	3 - 4
1 KVC 45/120 M	1x 220-240 v	1.85	2.5	12	11 - 2	6	4.5 - 5.5
1 KVC 45/120 T	3x 400 v	1.85	2.5	4.6	11 - 2	6	4.5 - 5.5
1 KVC 60/120 T	3x 400 v	2.2	3	5.4	11 - 2	7.5	5.5 - 6.5
1 KVC 70/120 T	3x 400 v	3	4	6.8	11 - 2	9	7 - 8
1 KVC 85/120 T	3x 400 v	3	4	7.8	11 - 2	10.5	9 - 10

MODEL	A	B	C	D	H	H2	H3	H4	Ø MANIFOLDS		WEIGHT kg	
									DNA (suc.)	DNM (del.)	Single-phase	Three-phase
1KVC 35/120	620	300	300	260	730	260	290	450	1" 1/4	1" 1/2	32	32
1KVC 45/120	620	300	300	260	730	260	290	450	1" 1/4	1" 1/2	44	34
1KVC 60/120	620	300	300	260	730	260	290	450	1" 1/4	1" 1/2	-	36
1KVC 70/120	620	300	300	260	730	260	290	450	1" 1/4	1" 1/2	-	38
1KVC 85/120	620	300	300	260	730	260	290	450	1" 1/4	1" 1/2	-	39

2 KVC 50 - CIVIL USE PRESSURE BOOSTER SETS

Pumped liquid temperature range: from -10 °C to +50 °C - Maximum ambient temperature: +40 °C

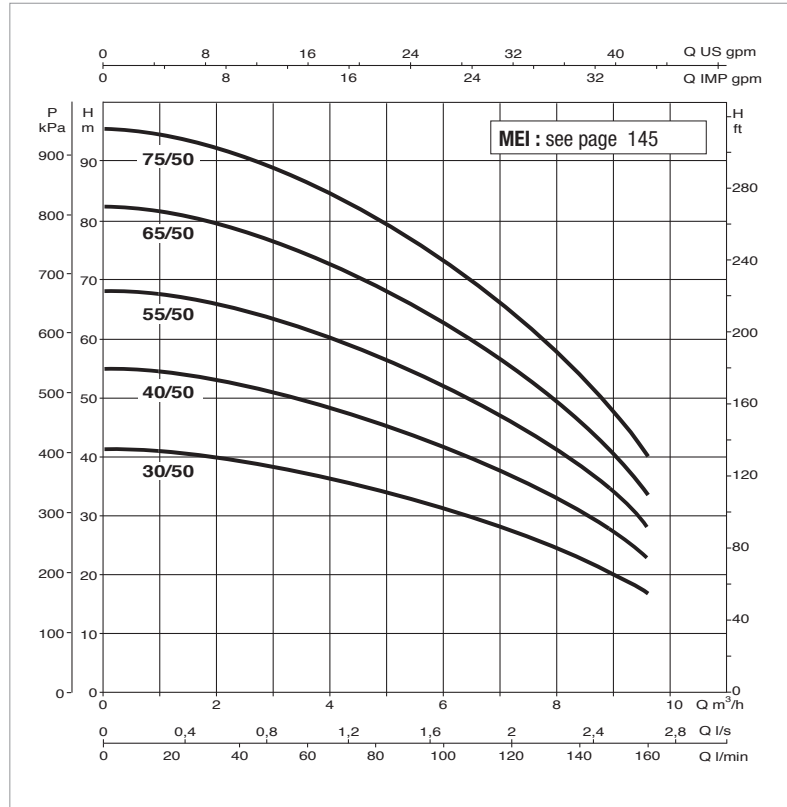
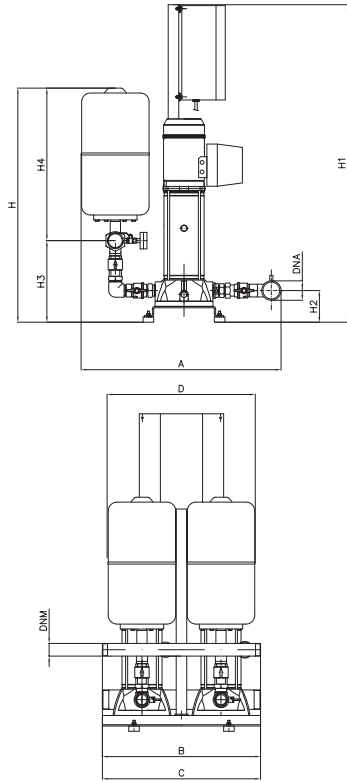

The performance curves are based on kinematic viscosity values = 1 mm²/s and density equivalent to 1000 kg/m³
Curve tolerance according to ISO 9906.

MODEL	POWER INPUT 50 Hz	P2 NOMINAL		In A	FLOW m ³ /h	MAX OBTAINABLE PRESSURE BAR	STANDARD PRESSURE BAR
		kW	HP				
2KVC 30/50 M	1x 220-240 v	2x 0,55	2x 0,75	2x 4	9 - 1	4	2,5
2KVC 30/50 T	3x 400 v	2x 0,55	2x 0,75	2x 1,4	9 - 1	4	2,5
2KVC 40/50 M	1x 220-240 v	2x 0,8	2x 1,1	2x 5,6	9 - 1	5,2	3,5
2KVC 40/50 T	3x 400 v	2x 0,8	2x 1,1	2x 2,2	9 - 1	5,2	3,5
2KVC 55/50 M	1x 220-240 v	2x 1	2x 1,36	2x 6,4	9 - 1	6,5	4,5
2KVC 55/50 T	3x 400 v	2x 1	2x 1,36	2x 2,6	9 - 1	6,5	4,5
2KVC 65/50 M	1x 220-240 v	2x 1,1	2x 1,5	2x 7,4	9 - 1	8	5,5
2KVC 65/50 T	3x 400 v	2x 1,1	2x 1,5	2x 3,1	9 - 1	8	5,5
2KVC 75/50 M	1x 220-240 v	2x 1,5	2x 2	2x 9	9 - 1	9	6,5
2KVC 75/50 T	3x 400 v	2x 1,5	2x 2	2x 3,6	9 - 1	9	6,5

MODEL	A	B	C	D	H	H1	H2	H3	H4	Ø MANIFOLDS		WEIGHT kg	
										DNA (suc.)	DNM (del.)	Single-phase	Three-phase
2KVC 30/50	760	550	500	560	800	920	95	260	610	2"	2"	70	70
2KVC 40/50	760	550	500	560	800	920	95	260	610	2"	2"	74	74
2KVC 55/50	760	550	500	560	800	920	95	260	610	2"	2"	76	76
2KVC 65/50	760	550	500	560	800	920	95	260	610	2"	2"	82	81
2KVC 75/50	760	550	500	560	800	920	95	260	610	2"	2"	84	83

2 KVC 80 - CIVIL USE PRESSURE BOOSTER SETS

Pumped liquid temperature range: from -10 °C to +50 °C - Maximum ambient temperature: +40 °C

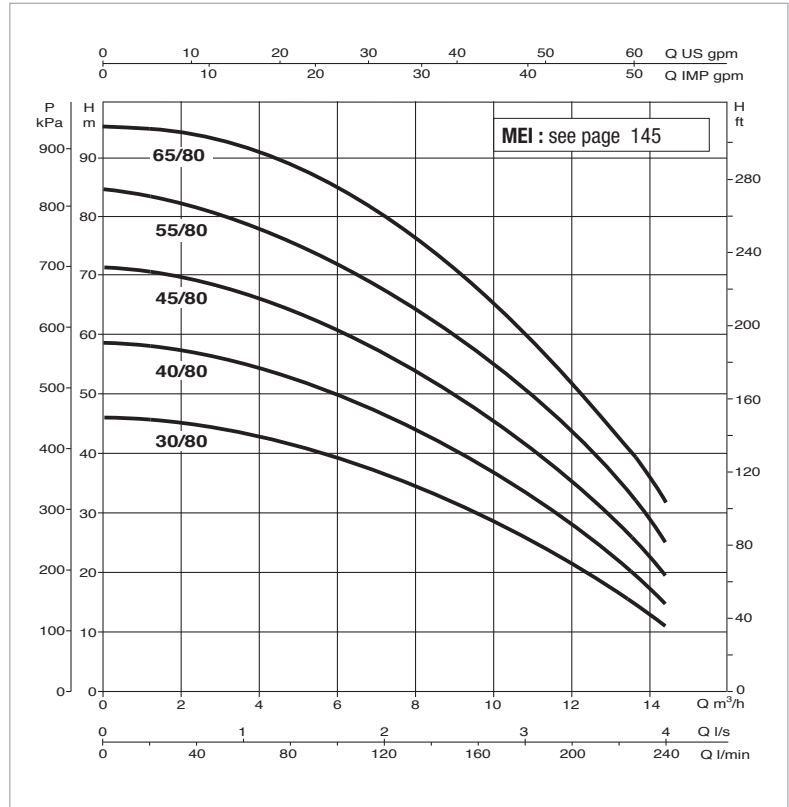
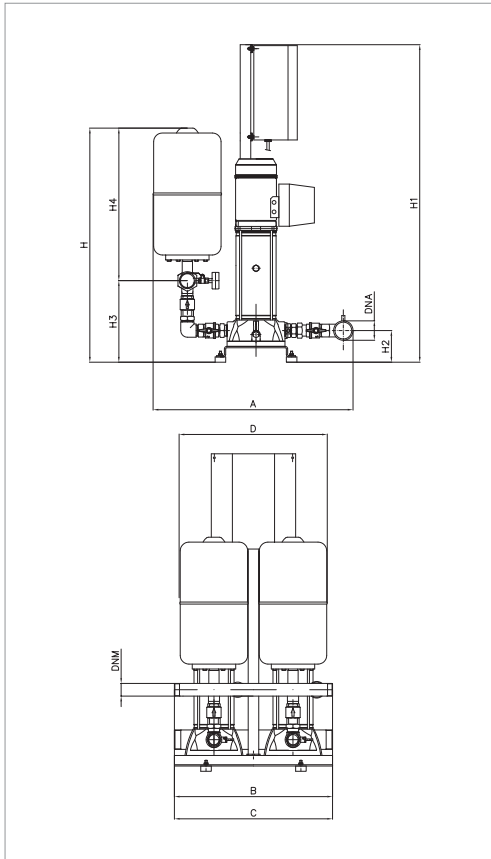

The performance curves are based on kinematic viscosity values = 1 mm²/s and density equivalent to 1000 kg/m³
Curve tolerance according to ISO 9906.

MODEL	POWER INPUT 50 Hz	P2 NOMINAL		In A	FLOW m ³ /h	MAX OBTAINABLE PRESSURE BAR	STANDARD PRESSURE BAR
		kW	HP				
2 KVC 30/80 M	1x 220-240 v	2x 0,8	2x 1,1	2x 5,6	14 - 2	4,5	3
2 KVC 30/80 T	3x 400 v	2x 0,8	2x 1,1	2x 2,2	14 - 2	4,5	3
2 KVC 40/80 M	1x 220-240 v	2x 1	2x 1,36	2x 6,5	14 - 2	5,5	4
2 KVC 40/80 T	3x 400 v	2x 1	2x 1,36	2x 2,6	14 - 2	5,5	4
2 KVC 45/80 M	1x 220-240 v	2x 1,1	2x 1,5	2x 7,4	14 - 2	6,8	5
2 KVC 45/80 T	3x 400 v	2x 1,1	2x 1,5	2x 3,1	14 - 2	6,8	5
2 KVC 55/80 M	1x 220-240 v	2x 1,5	2x 2	2x 9	14 - 2	8	6
2 KVC 55/80 T	3x 400 v	2x 1,5	2x 2	2x 3,6	14 - 2	8	6
2 KVC 65/80 T	3x 400 v	2x 2,2	2x 3	2x 4	14 - 2	9,2	7

MODEL	A	B	C	D	H	H1	H2	H3	H4	Ø MANIFOLDS		WEIGHT kg	
										DNA (suc.)	DNM (del.)	Single-phase	Three-phase
2KVC 30/80	760	550	500	560	800	920	95	260	610	2"	2"	73	73
2KVC 40/80	760	550	500	560	800	920	95	260	610	2"	2"	76	76
2KVC 45/80	760	550	500	560	800	920	95	260	610	2"	2"	82	82
2KVC 55/80	760	550	500	560	800	920	95	260	610	2"	2"	84	82
2KVC 65/80	760	550	500	560	800	920	95	260	610	2"	2"	-	85

2 KVC 120 - CIVIL USE PRESSURE BOOSTER SETS

Pumped liquid temperature range: from -10 °C to +50 °C - Maximum ambient temperature: +40 °C

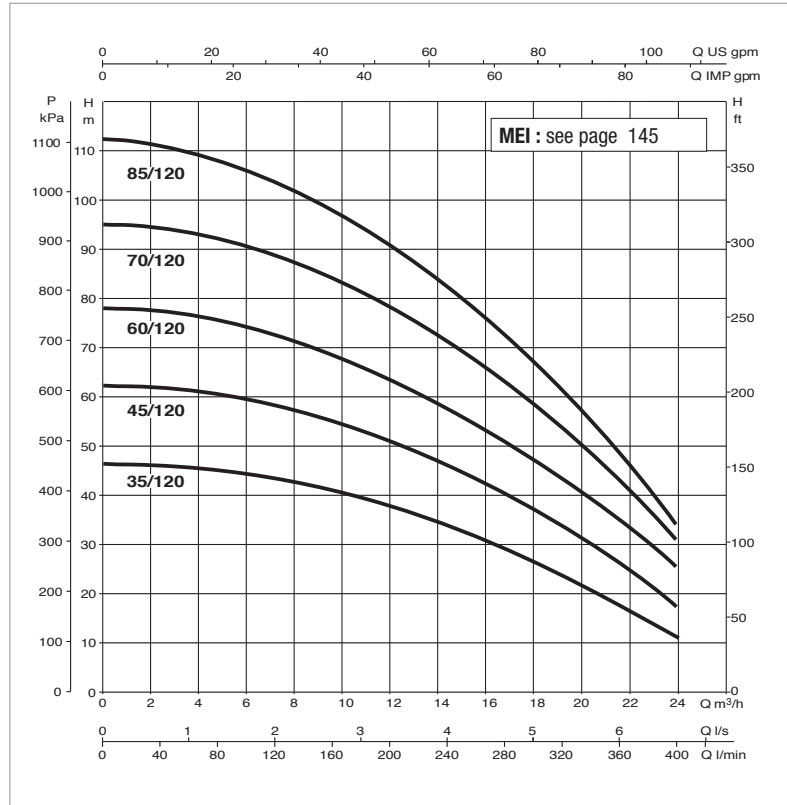
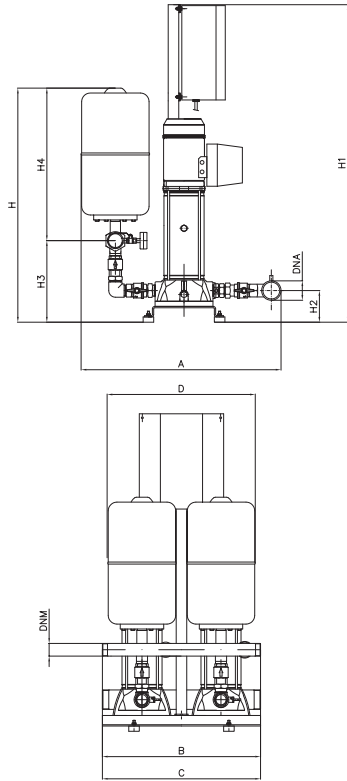

The performance curves are based on kinematic viscosity values = 1 mm²/s and density equivalent to 1000 kg/m³
Curve tolerance according to ISO 9906.

MODEL	POWER INPUT 50 Hz	P2 NOMINAL		In A	FLOW m ³ /h	MAX OBTAINABLE PRESSURE BAR	STANDARD PRESSURE BAR
		kW	HP				
2 KVC 35/120 M	1x 220-240 v	2x 1,1	2x 1,5	2x 7,4	22-2	4,5	3
2 KVC 35/120 T	3x 400 v	2x 1,1	2x 1,5	2x 3,5	22-2	4,5	3
2 KVC 45/120 M	1x 220-240 v	2x 1,85	2x 2,5	2x 12	22-2	6	4
2 KVC 45/120 T	3x 400 v	2x 1,85	2x 2,5	2x 4,6	22-2	6	4
2 KVC 60/120 T	3x 400 v	2x 2,2	2x 3	2x 5,4	22-2	7,5	5
2 KVC 70/120 T	3x 400 v	2x 3	2x 4	2x 6,8	22-2	9	6
2 KVC 85/120 T	3x 400 v	2x 3	2x 4	2x 7,8	22-2	10,5	7

MODEL	A	B	C	D	H	H1	H2	H3	H4	Ø MANIFOLDS		WEIGHT kg	
										DNA (suc.)	DNM (del.)	Single-phase	Three-phase
2KVC 35/120	760	550	500	560	800	920	95	260	610	2"	2"	82	82
2KVC 45/120	760	550	500	560	800	920	95	260	610	2"	2"	86	86
2KVC 60/120	760	550	500	560	800	920	95	260	610	2"	2"	-	90
2KVC 70/120	760	550	500	560	800	920	95	260	610	2"	2"	-	94
2KVC 85/120	760	550	500	560	800	920	95	260	610	2"	2"	-	95

3 KVC 50 - CIVIL USE PRESSURE BOOSTER SETS

Pumped liquid temperature range: from -10 °C to +50 °C - Maximum ambient temperature: +40 °C

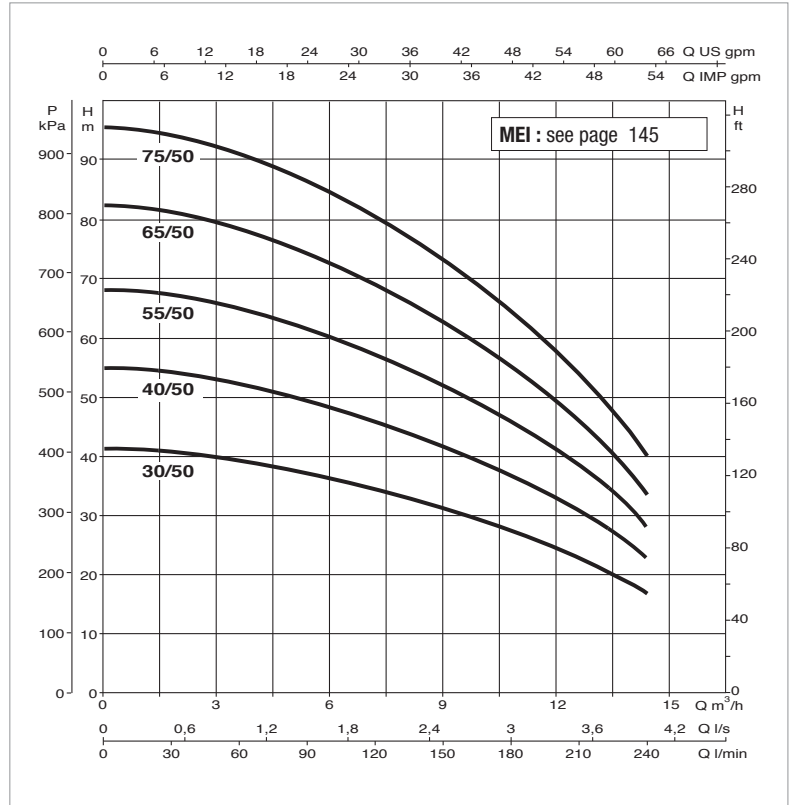
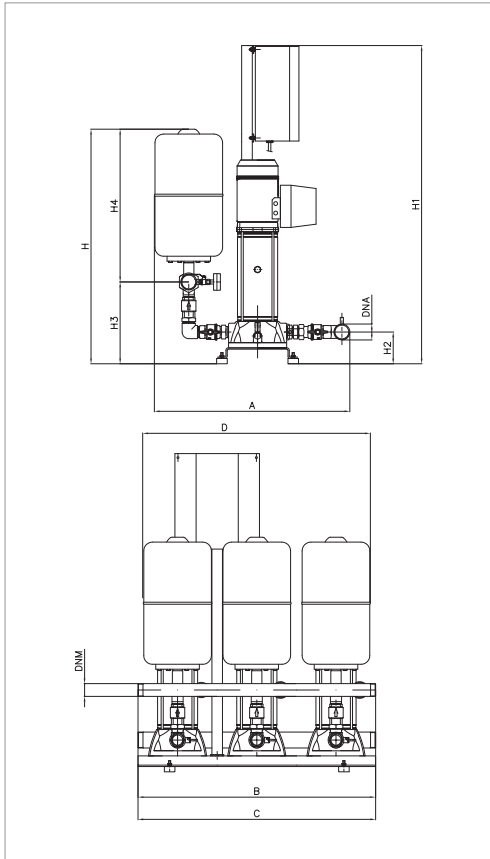

The performance curves are based on kinematic viscosity values = 1 mm²/s and density equivalent to 1000 kg/m³
Curve tolerance according to ISO 9906.

PRESSURE SETS

MODEL	POWER INPUT 50 Hz	P2 NOMINAL		In A	FLOW m ³ /h	MAX OBTAINABLE PRESSURE BAR	PRESSURE SWITCH CALIBRATION BAR
		kW	HP				
3KVC 30/50 M	1x 220-240 v	3x 0,55	3x 0,75	3x 4	13,5 - 1	4	1,5 - 3,5
3KVC 30/50 T	3x 400 v	3x 0,55	3x 0,75	3x 1,4	13,5 - 1	4	1,5 - 3,5
3KVC 40/50 M	1x 220-240 v	3x 0,8	3x 1,1	3x 5,6	13,5 - 1	5,2	3 - 5
3KVC 40/50 T	3x 400 v	3x 0,8	3x 1,1	3x 2,2	13,5 - 1	5,2	3 - 5
3KVC 55/50 M	1x 220-240 v	3x 1	3x 1,36	3x 6,4	13,5 - 1	6,5	4 - 6
3KVC 55/50 T	3x 400 v	3x 1	3x 1,36	3x 2,6	13,5 - 1	6,5	4 - 6
3KVC 65/50 M	1x 220-240 v	3x 1,1	3x 1,5	3x 7,4	13,5 - 1	8	5,5 - 7,5
3KVC 65/50 T	3x 400 v	3x 1,1	3x 1,5	3x 3,1	13,5 - 1	8	5,5 - 7,5
3KVC 75/50 M	1x 220-240 v	3x 1,5	3x 2	3x 9	13,5 - 1	9	6,5 - 8,5
3KVC 75/50 T	3x 400 v	3x 1,5	3x 2	3x 3,6	13,5 - 1	9	6,5 - 8,5

MODEL	A	B	C	D	H	H1	H2	H3	H4	Ø MANIFOLDS		WEIGHT kg	
										DNA (suc.)	DNM (del.)	Single-phase	Three-phase
3KVC 30/50	650	900	810	850	950	1100	100	410	610	2" 1/2	2" 1/2	109	109
3KVC 40/50	650	900	810	850	950	1100	100	410	610	2" 1/2	2" 1/2	115	115
3KVC 55/50	650	900	810	850	950	1100	100	410	610	2" 1/2	2" 1/2	119	119
3KVC 65/50	650	900	810	850	950	1100	100	410	610	2" 1/2	2" 1/2	128	127
3KVC 75/50	650	900	810	850	950	1100	100	410	610	2" 1/2	2" 1/2	132	130

3 KVC 80 - CIVIL USE PRESSURE BOOSTER SETS

Pumped liquid temperature range: from -10 °C to +50 °C - Maximum ambient temperature: +40 °C

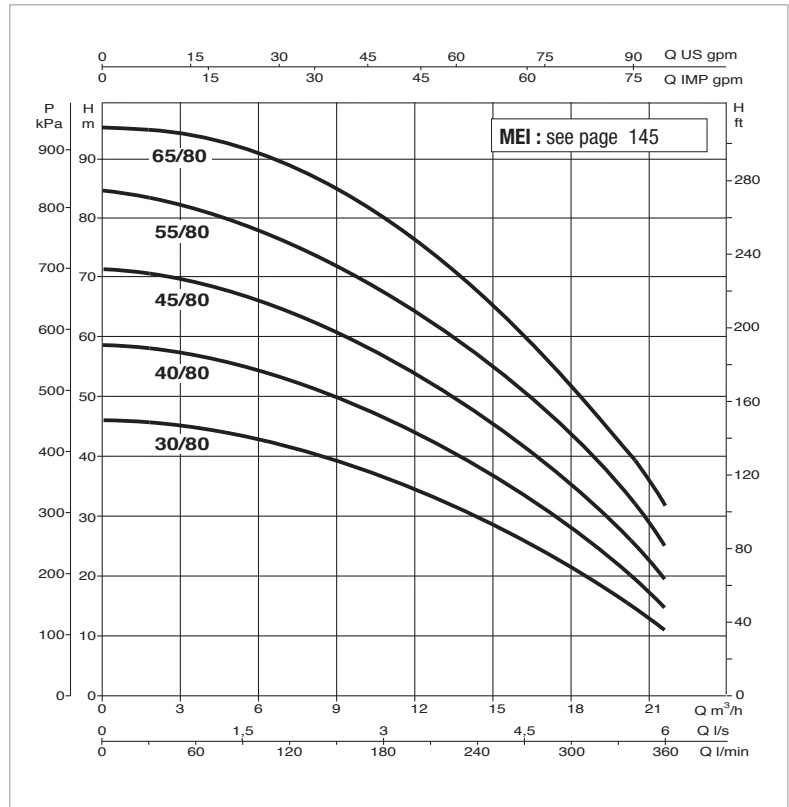
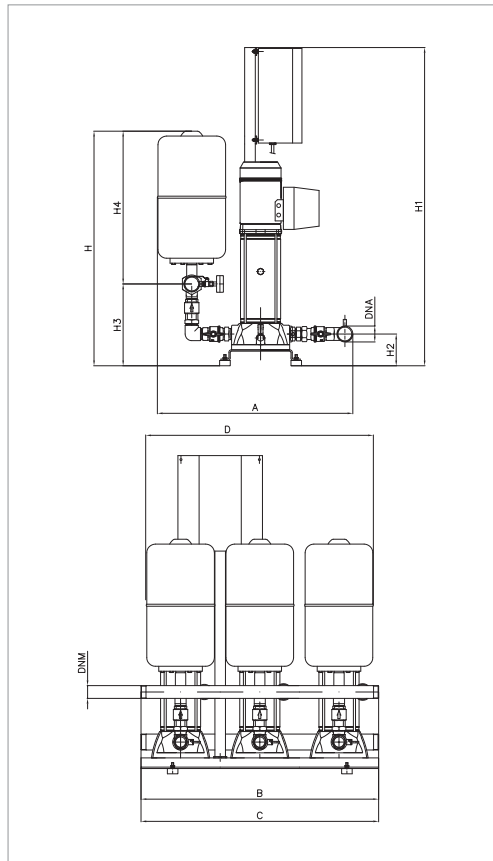

The performance curves are based on kinematic viscosity values = 1 mm²/s and density equivalent to 1000 kg/m³
Curve tolerance according to ISO 9906.

MODEL	POWER INPUT 50 Hz	P2 NOMINAL		In A	FLOW m ³ /h	MAX OBTAINABLE PRESSURE BAR	PRESSURE SWITCH CALIBRATION BAR
		kW	HP				
3KVC 30/80 M	1x 220-240 v	3x 0,8	3x 1,1	3x 5,6	21 - 2	4,5	2 - 4
3KVC 30/80 T	3x 400 v	3x 0,8	3x 1,1	3x 2,2	21 - 2	4,5	2 - 4
3KVC 40/80 M	1x 220-240 v	3x 1	3x 1,36	3x 6,5	21 - 2	5,5	3 - 5
3KVC 40/80 T	3x 400 v	3x 1	3x 1,36	3x 2,6	21 - 2	5,5	3 - 5
3KVC 45/80 M	1x 220-240 v	3x 1,1	3x 1,5	3x 7,4	21 - 2	6,8	4 - 6
3KVC 45/80 T	3x 400 v	3x 1,1	3x 1,5	3x 3,1	21 - 2	6,8	4 - 6
3KVC 55/80 M	1x 220-240 v	3x 1,5	3x 2	3x 9	21 - 2	8	5 - 7
3KVC 55/80 T	3x 400 v	3x 1,5	3x 2	3x 3,6	21 - 2	8	5 - 7
3KVC 65/80 T	3x 400 v	3x 2,2	3x 3	3x 4	21 - 2	9,2	6 - 8

MODEL	A	B	C	D	H	H1	H2	H3	H4	Ø MANIFOLDS		WEIGHT kg	
										DNA (suc.)	DNM (del.)	Single-phase	Three-phase
3KVC 30/80	650	900	810	850	950	1100	100	410	610	2" 1/2	2" 1/2	115	114
3KVC 40/80	650	900	810	850	950	1100	100	410	610	2" 1/2	2" 1/2	119	119
3KVC 45/80	650	900	810	850	950	1100	100	410	610	2" 1/2	2" 1/2	128	128
3KVC 55/80	650	900	810	850	950	1100	100	410	610	2" 1/2	2" 1/2	131	128
3KVC 65/80	650	900	810	850	950	1100	100	410	610	2" 1/2	2" 1/2	-	133

3 KVC 120 - CIVIL USE PRESSURE BOOSTER SETS

Pumped liquid temperature range: from -10 °C to +50 °C - Maximum ambient temperature: +40 °C

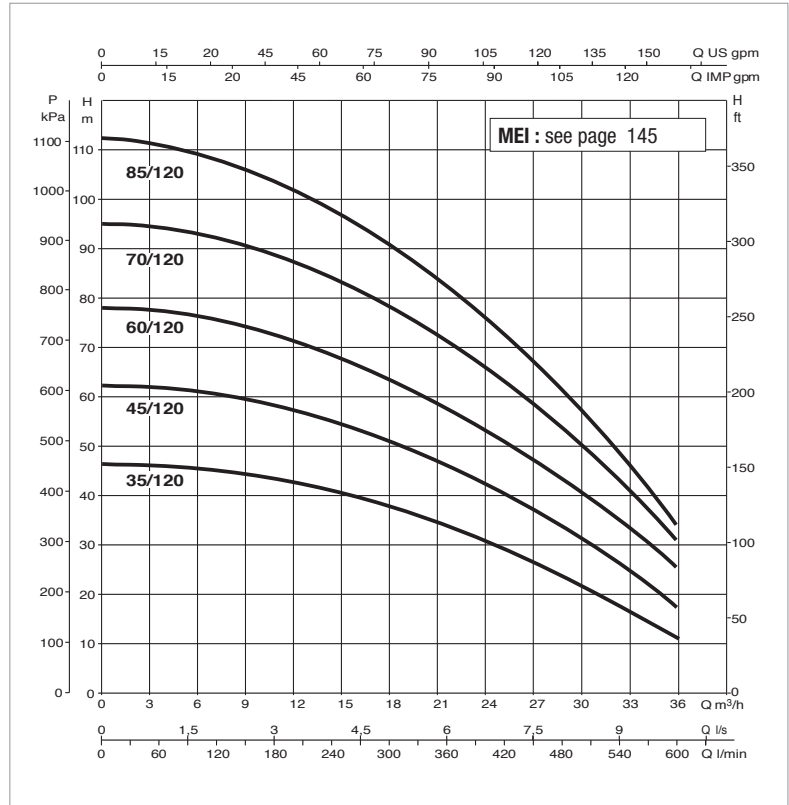
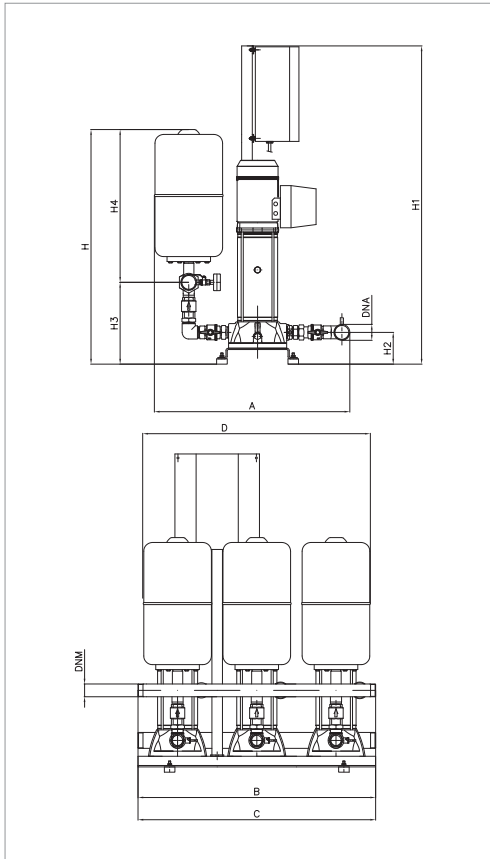

The performance curves are based on kinematic viscosity values = 1 mm²/s and density equivalent to 1000 kg/m³
Curve tolerance according to ISO 9906.

MODEL	POWER INPUT 50 Hz	P2 NOMINAL		In A	FLOW m ³ /h	MAX OBTAINABLE PRESSURE BAR	PRESSURE SWITCH CALIBRATION BAR
		kW	HP				
3KVC 35/120 M	1x 220-240 v	3x 1,1	3x 1,5	3x 7,4	33-2	4,5	2-4
3KVC 35/120 T	3x 400 v	3x 1,1	3x 1,5	3x 3,5	33-2	4,5	2-4
3KVC 45/120 M	1x 220-240 v	3x 1,85	3x 2,5	3x 12	33-2	6	3,5-5,5
3KVC 45/120 T	3x 400 v	3x 1,85	3x 2,5	3x 4,6	33-2	6	3,5-5,5
3KVC 60/120 T	3x 400 v	3x 2,2	3x 3	3x 5,4	33-2	7,5	4,5-6,5
3KVC 70/120 T	3x 400 v	3x 3	3x 4	3x 6,8	33-2	9	6-8
3KVC 85/120 T	3x 400 v	3x 3	3x 4	3x 7,8	33-2	10,5	8-10

MODEL	A	B	C	D	H	H1	H2	H3	H4	Ø MANIFOLDS		WEIGHT kg	
										DNA (suc.)	DNM (del.)	Single-phase	Three-phase
3KVC 35/120	650	900	810	850	950	1100	100	410	610	2" 1/2	2" 1/2	128	128
3KVC 45/120	650	900	810	850	950	1100	100	410	610	2" 1/2	2" 1/2	134	134
3KVC 60/120	650	900	810	850	950	1100	100	410	610	2" 1/2	2" 1/2	-	140
3KVC 70/120	650	900	810	850	950	1100	100	410	610	2" 1/2	2" 1/2	-	146
3KVC 85/120	650	900	810	850	950	1100	100	410	610	2" 1/2	2" 1/2	-	148

1/2/3 KV 3-6-10

PRESSURE BOOSTER SETS WITH ONE VERTICAL PUMP

TECHNICAL DATA

Operating range: from 1,8 to 43 m³/h

Pumped liquid: clean, free of solids and abrasives, non viscous, non aggressive, non crystallised and chemically neutral, with properties similar to water.

Pumped liquid temperature range: from -15 °C to +70 °C.

Maximum ambient temperature: +40 °C.

Maximum operating pressure: PN16.

Special executions on request: contact our sales network.

Protection class: IP44

IE2 motors as standard from 0,75 kW to 5,5 kW - IE3 \geq 7,5 kW



APPLICATIONS

Water lifting sets particularly suited for domestic use, and small civil, agricultural, or industrial systems. The use of vertical axis multistage centrifugal electric pumps ensures high performance results. Their main features are limited space requirements, sturdiness, absolute reliability, and extremely quiet operation.

CONSTRUCTION FEATURES

SETS WITH 1 PUMP

HYDRAULIC SECTION

1 KV 3 - KV 6 - KV 10 vertical multistage electric pumps.

1 membrane tank.

Radial manometer.

Tropicalized galvanised steel threaded delivery manifold.

Ball valves with unions on the suction and delivery ports.

Isolator valve on the suction.

Radial manometer with isolator valve.

Flexible anti-vibration hose.

Tropicalized galvanized cast iron female plug for closing the manifold.

ELECTRICAL SECTION

Single phase power input

1 2-pole pressure switch with cable gland connected to the motor and complete with power input cable and plug.

Three phase power input

Remote motor protection control panel with reset pushbutton, secured to the motor by means of a tropicalized steel bracket, and also electrically connected to the motor, with terminal box for connection to the power input line - 1 2-pole pressure switch with cable gland connected to the remote motor protector control panel.

The sets are supplied in a sturdy cardboard packaging on wooden pallet and instruction leaflet with electric diagram.

SETS WITH 2 3 PUMPS

HYDRAULIC SECTION

2 - 3 KV 3-6-10 vertical multistage electric pumps.

Tropicalized galvanized sheet steel base complete with 4 rubber anti-vibration feet.

Galvanised steel suction and delivery manifolds, threaded for 2 KV 3-6-10 and 3 KV 3-6 sets, flanged for 3 KVE 10 sets.

Plugs or blind flanges for closing the manifolds.

Ball valves with unions on the suction and delivery ports of each pump.

Check valves on the suction port of each pump.

2 membrane tanks.

Radial manometer with isolator valve.

Electric control panel support in galvanised steel.

1/2/3 KV 3-6-10

PRESSURE BOOSTER SETS WITH ONE VERTICAL PUMP

2 KV ELECTRIC COMPONENTS

IP 55 protection class self-extinguishing, shock-resistant plastic electric control panel. The control panel protects the electric pumps and controls the sequence, keeping the system at an average pressure value already preset at the factory. The average pressure value may be changed using a trimmer found inside the control panel. The pump starting order is switched at each operating cycle. The pressure is measured through a pressure transmitter on the delivery manifold.

FRONT PANEL COMPONENTS:

General disconnecter with padlockable door lock.
AUT-MAN operation selection points.
Alarm RESET pushbutton.
Operation, stop, and alarm notification lamps.

PANEL INTERNAL COMPONENTS:

Electronic control card with protection fuses and contactors.
Power input connection terminal (single phase or three phase).
- Dry run or overpressure pressure switch connection terminals (optional).
Alarm notification N.O. contacts.
Function selection mini dip switch (pressure transmitter or pressure switches, standard or additional tanks).

3KV ELECTRIC COMPONENTS

IP 55 protection class self-extinguishing, shock-resistant plastic electric control panel. The control panel includes the general switch, the electric pump protection thermal magnetic circuit breakers, the electric pump start order switch system, the 24 V low voltage circuit for the control of the pressure switches, MAN-O-AUT selectors (single phase operation control panel pushbuttons), notification lamps at the front of the panel. Installed on appropriate support on the pump base. Pump start/stop pre-calibrated pressure switches.

The electric control panel is ready for the connection of:

Dry run protection float or pressure switch kit (*).

Overpressure stop pressure switch kit (*).

(* available separately as optional).

The sets are supplied in a sturdy cardboard packaging on wooden pallet and installation / maintenance manual with electric diagram.

MATERIALS

N.	PARTS	MATERIALS
4	IMPELLER	TECHNOPOLYMER B
6	DIFFUSER	TECHNOPOLYMER B
7A	PUMP SHAFT	AISI 416 STAINLESS STEEL X12 CrS 13 UNI 6900/71
16	MECHANICAL SEAL	CARBON / CERAMIC
28	OR RING	EPDM RUBBER
69	LINER	AISI 304 STAINLESS STEEL X5 CrNi 1810 UNI 6900/71
95	OR RING	EPDM RUBBER
96	SUCTION BODY	CAST IRON 200 UNI ISO 185
97	DELIVERY BODY	CAST IRON 200 UNI ISO 185
98	DIFFUSER BODY	TECHNOPOLYMER B

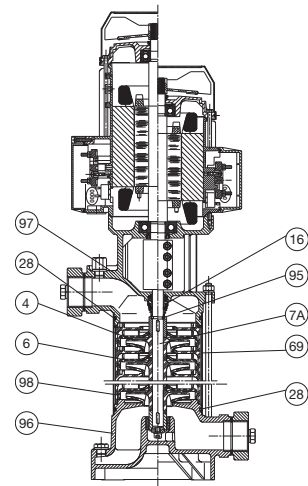

1 KV 3 - CIVIL USE PRESSURE BOOSTER SETS

Pumped liquid temperature range: from -15°C to +70°C - Maximum ambient temperature: +40 °C - Max flow rate: 7.2 m³/h

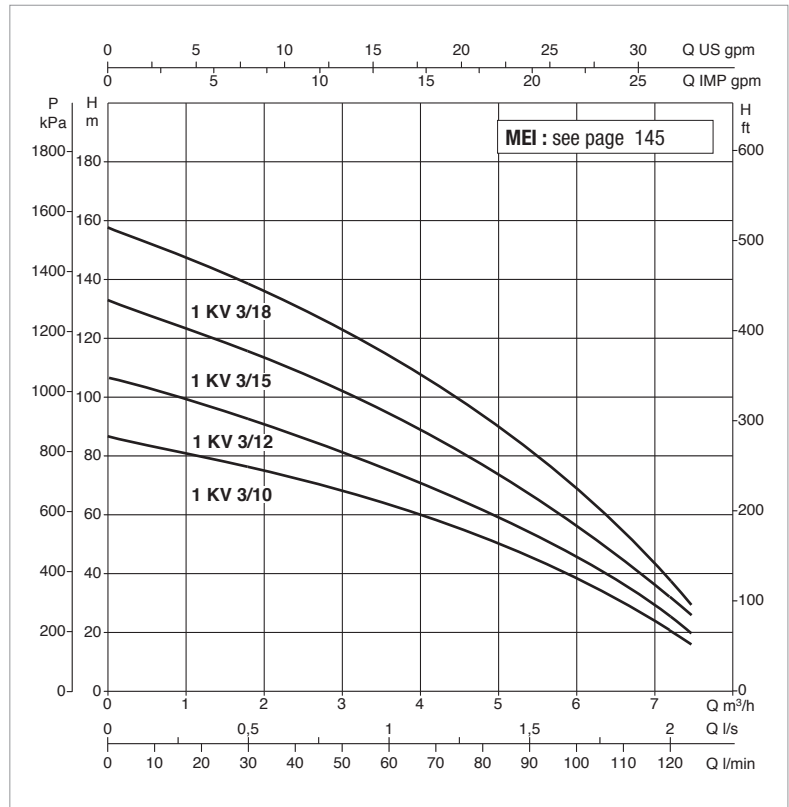
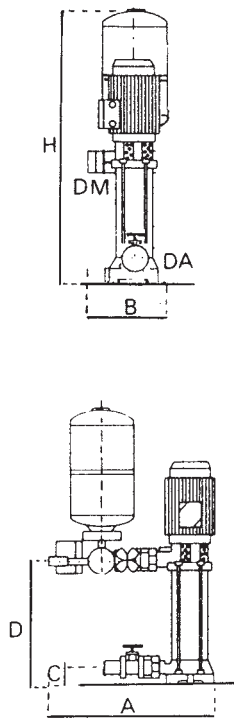

The performance curves are based on kinematic viscosity values = 1 mm²/s and density equivalent to 1000 kg/m³
Curve tolerance according to ISO 9906.

MODEL	POWER INPUT 50 Hz	P2 NOMINAL		In A	FLOW m ³ /h	PRESSURE SWITCH CALIBRATION BAR	MAX OBTAINABLE PRESSURE BAR
		kW	HP				
1 KV 3/10 M	1x220-240 V ~	1.1	1.5	7.8	7.2-1.8	5÷6	8.2
1 KV 3/12 M	1x220-240 V ~	1.5	2	9.6	7.2-1.8	6÷1	10.2
1 KV 3/10 T	3x400 V ~	1.1	1.5	3.2	7.2-1.8	5÷6	8.2
1 KV 3/12 T	3x400 V ~	1.5	2	3.7	7.2-1.8	6÷1	10.2
1 KV 3/15 T	3x400 V ~	1.85	2.5	4.3	7.2-1.8	8÷9	13
1 KV 3/18 T	3x400 V ~	2.2	3	5.8	7.2-1.8	10÷11	15.8

MODEL	A	B	C	D	H	Ø MANIFOLDS		WEIGHT kg
						DNA (suc.)	DNM (del.)	
1 KV 3/10 M	760	300	120	473	993	1 1/4"	1 1/2"	39
1 KV 3/12 M	760	300	120	596	1116	1 1/4"	1 1/2"	40
1 KV 3/10 T	760	300	120	473	993	1 1/4"	1 1/2"	39
1 KV 3/12 T	760	300	120	596	1116	1 1/4"	1 1/2"	40
1 KV 3/15 T	760	300	120	692	1212	1 1/4"	1 1/2"	41
1 KV 3/18 T	760	300	120	788	1318	1 1/4"	1 1/2"	47

1 KV 6 - CIVIL USE PRESSURE BOOSTER SETS

Pumped liquid temperature range: from -15°C to +70°C - Maximum ambient temperature: +40 °C - Max flow rate: 9 m³/h

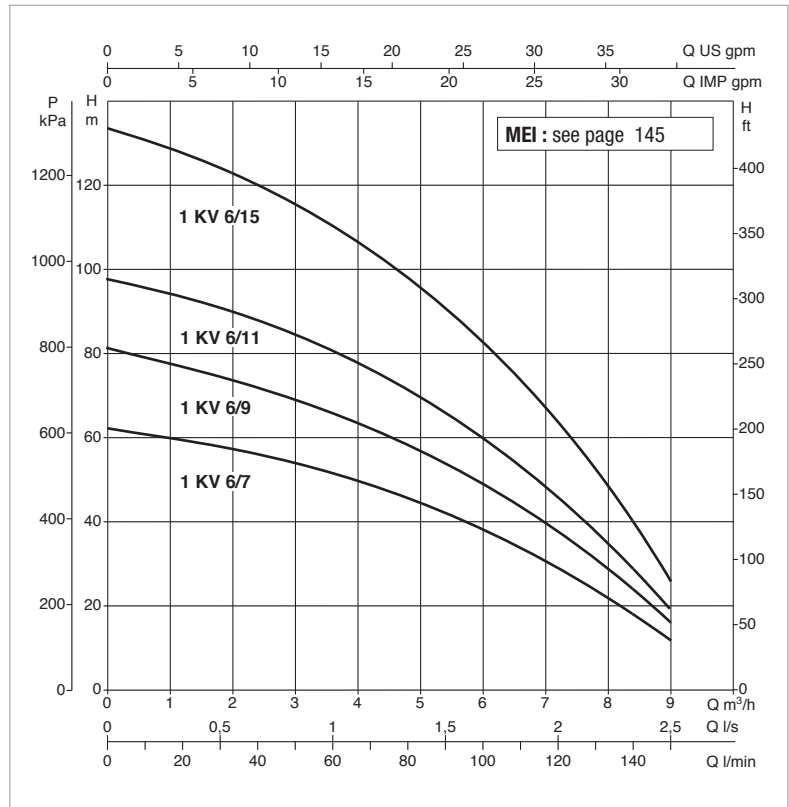
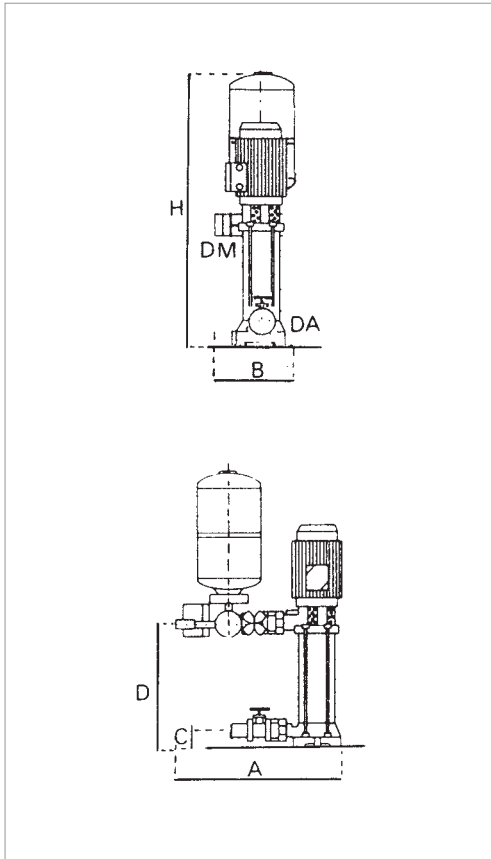

The performance curves are based on kinematic viscosity values = 1 mm²/s and density equivalent to 1000 kg/m³
Curve tolerance according to ISO 9906.

MODEL	POWER INPUT 50 Hz	P2 NOMINAL		In A	FLOW m³/h	PRESSURE SWITCH CALIBRATION BAR	MAX OBTAINABLE PRESSURE BAR
		kW	HP				
1 KV 6/7 M	1x220-240 V ~	1.1	1.5	7.5	8.5-2.4	4÷5	6
1 KV 6/9 M	1x220-240 V ~	1.5	2	9.4	8.5-2.4	5÷6	8
1 KV 6/7 T	3x400 V ~	1.1	1.5	2.9	8.5-2.4	4÷5	6
1 KV 6/9 T	3x400 V ~	1.5	2	3.6	8.5-2.4	5÷6	8
1 KV 6/11 T	3x400 V ~	1.85	2.5	4.2	8.5-2.4	6÷7	9.8
1 KV 6/15 T	3x400 V ~	2.2	3	6.3	8.5-2.4	8÷9	13

MODEL	A	B	C	D	H	Ø MANIFOLDS		WEIGHT kg
						DNA (suc.)	DNM (del.)	
KV 6/7 M	760	300	120	436	956	1¼"	1½"	37
1 KV 6/9 M	760	300	120	500	1020	1¼"	1½"	40
1 KV 6/7 T	760	300	120	436	956	1¼"	1½"	37
1 KV 6/9 T	760	300	120	500	1020	1¼"	1½"	40
1 KV 6/11 T	760	300	120	564	1084	1¼"	1½"	38
1 KV 6/15 T	760	300	120	692	1212	1¼"	1½"	45

1 KV 10 - CIVIL USE PRESSURE BOOSTER SETS

Pumped liquid temperature range: from -15 °C to +70 °C - Maximum ambient temperature: +40 °C - Max flow rate: 14.5 m³/h

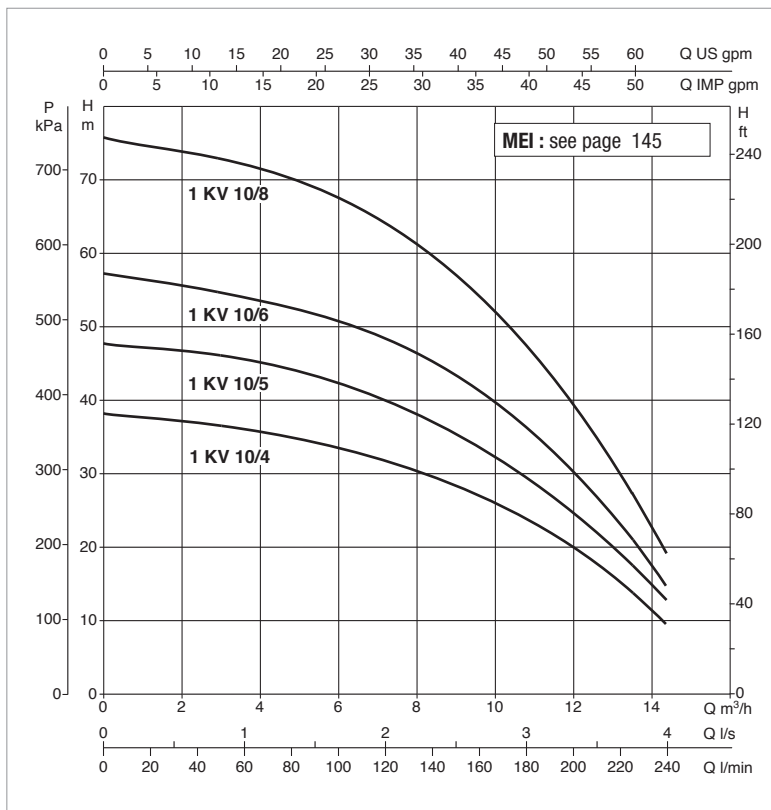
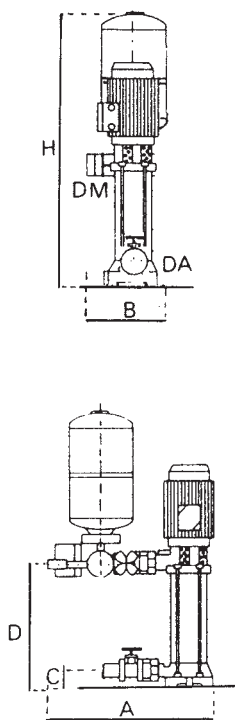

The performance curves are based on kinematic viscosity values = 1 mm²/s and density equivalent to 1000 kg/m³
Curve tolerance according to ISO 9906.

MODEL	POWER INPUT 50 Hz	P2 NOMINAL		In A	FLOW m³/h	PRESSURE SWITCH CALIBRATION BAR	MAX OBTAINABLE PRESSURE BAR
		kW	HP				
1 KV 10/4 M	1x220-240 V ~	1.1	1.5	8.3	13.2-3.0	2÷3	3.8
1 KV 10/5 M	1x220-240 V ~	1.5	2	10.4	13.2-3.0	3÷4	4.8
1 KV 10/4 T	3x400 V ~	1.1	1.5	3.5	13.2-3.0	2÷3	3.8
1 KV 10/5 T	3x400 V ~	1.5	2	3.9	13.2-3.0	3÷4	4.8
1 KV 10/6 T	3x400 V ~	1.85	2.5	5	13.2-3.0	4÷5	5.5
1 KV 10/8 T	3x400 V ~	2.2	3	6.8	13.2-3.0	5÷6	7.2

MODEL	A	B	C	D	H	Ø MANIFOLDS		WEIGHT kg
						DNA (suc.)	DNM (del.)	
1 KV 10/4 M	760	300	120	340	860	1¼"	1½"	35
1 KV 10/5 M	760	300	120	372	892	1¼"	1½"	40
1 KV 10/4 T	760	300	120	340	860	1¼"	1½"	35
1 KV 10/5 T	760	300	120	372	892	1¼"	1½"	40
1 KV 10/6 T	760	300	120	404	920	1¼"	1½"	38
1 KV 10/8 T	760	300	120	468	988	1¼"	1½"	43

2 KV 3 - CIVIL USE PRESSURE BOOSTER SETS

Pumped liquid temperature range: from -15 °C to +70 °C - Maximum ambient temperature: +40 °C - Max flow rate: 14.4 m³/h

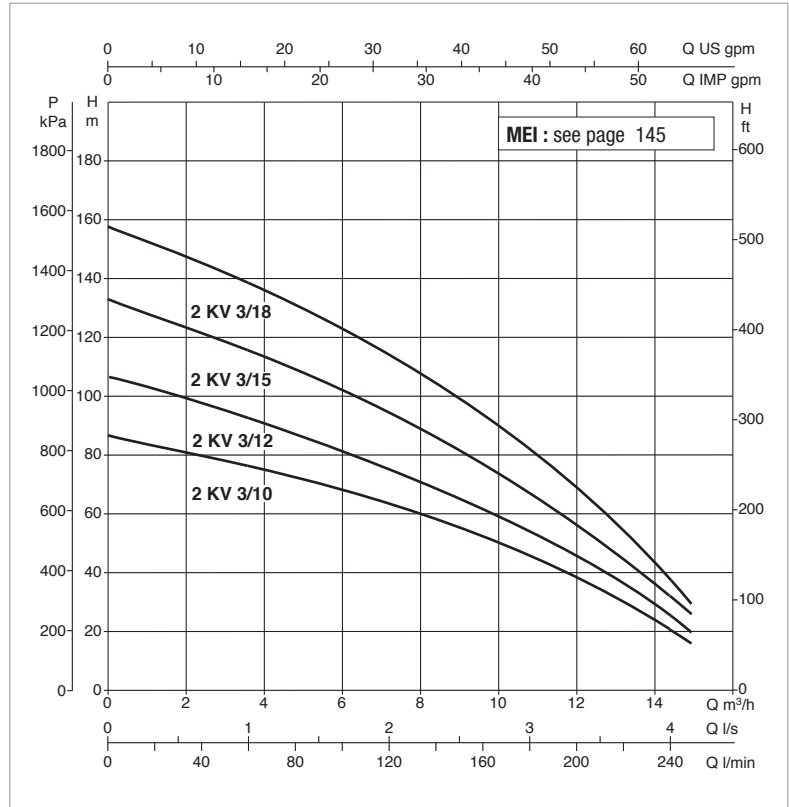
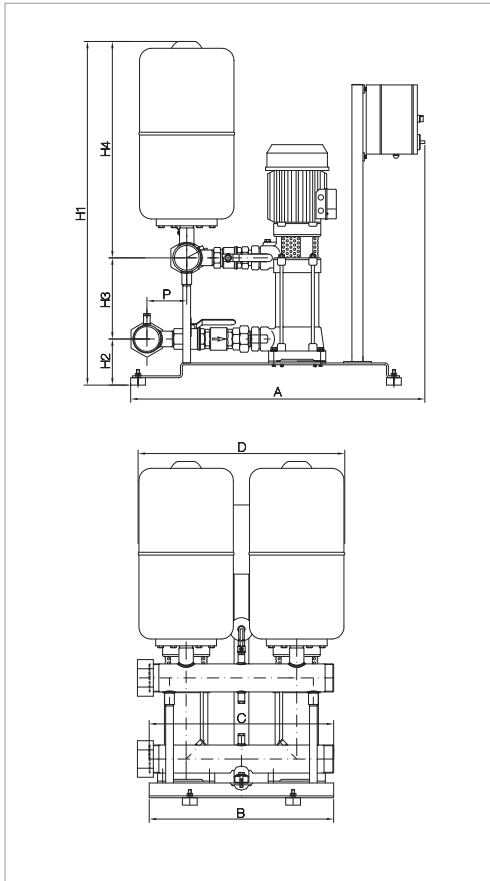

The performance curves are based on kinematic viscosity values = 1 mm²/s and density equivalent to 1000 kg/m³

Curve tolerance according to ISO 9906.

Overall performance taking into account TWO pumps working at the same time.

MODEL	POWER INPUT 50 Hz	P2 NOMINAL		In A	FLOW m ³ /h	MAX OBTAINABLE PRESSURE BAR	STANDARD PRESSURE BAR
		kW	HP				
2 KV 3/10 M	1x220-240 V ~	2x1,1	2x1,5	2x7,8	14.4-3.6	8.2	5
2 KV 3/12 M	1x220-240 V ~	2x1,5	2x2	2x9,6	14.4-3.6	10.2	6
2 KV 3/10 T	3x400 V ~	2x1,1	2x1,5	2x3,2	14.4-3.6	8.2	5
2 KV 3/12 T	3x400 V ~	2x1,5	2x2	2x3,7	14.4-3.6	10.2	6
2 KV 3/15 T	3x400 V ~	2x1,85	2x2,5	2x4,3	14.4-3.6	13	7
2 KV 3/18 T	3x400 V ~	2x2,2	2x3	2x5,8	14.4-3.6	15.8	9

MODEL	A	B	C	D	P	H1	H2	H3	H4	Ø MANIFOLDS		WEIGHT kg
										DNA (suc.)	DNM (del.)	
2 KV 3/10 M	798	500	500	560	108	1117	125	412	580	2"	2"	118
2 KV 3/12 M	798	500	500	560	108	1181	125	476	580	2"	2"	124
2 KV 3/10 T	798	500	500	560	108	1117	125	412	580	2"	2"	123
2 KV 3/12 T	798	500	500	560	108	1117	125	476	580	2"	2"	129
2 KV 3/15 T	798	500	500	560	108	1277	125	572	580	2"	2"	134
2 KV 3/18 T	798	500	500	560	108	1373	125	668	580	2"	2"	141

2 KV 6 - CIVIL USE PRESSURE BOOSTER SETS

Pumped liquid temperature range: from -15 °C to +70 °C - Maximum ambient temperature: +40 °C - Max flow rate: 18 m³/h

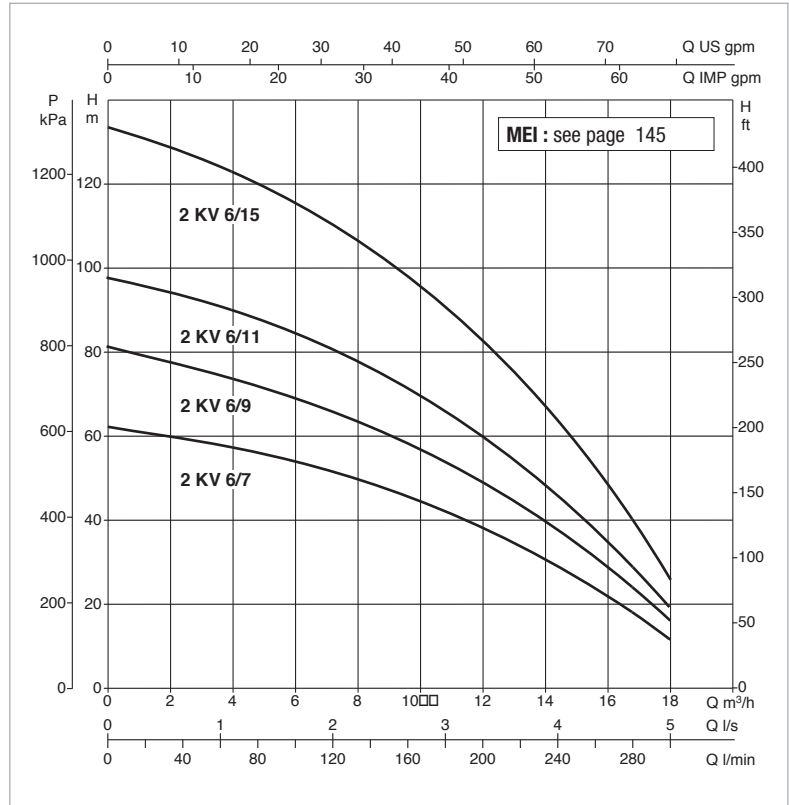
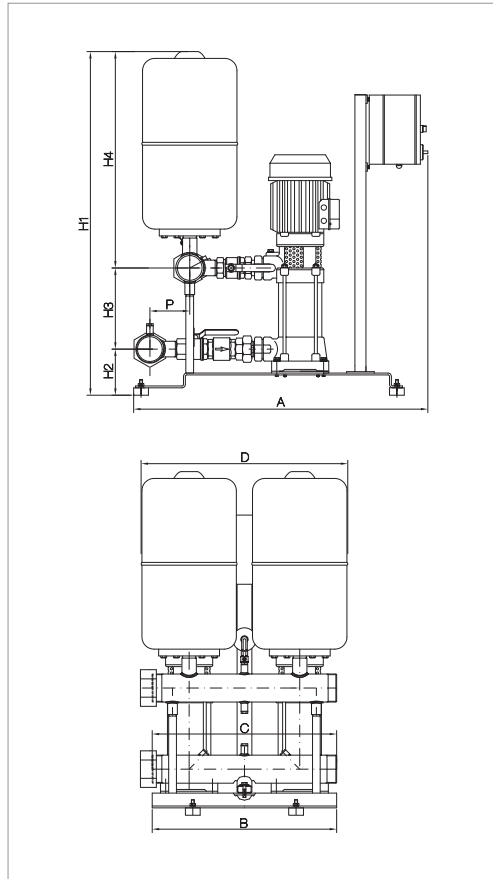

The performance curves are based on kinematic viscosity values = 1 mm²/s and density equivalent to 1000 kg/m³

Curve tolerance according to ISO 9906.

Overall performance taking into account TWO pumps working at the same time.

MODEL	POWER INPUT 50 Hz	P2 NOMINAL		In A	FLOW m ³ /h	MAX OBTAINABLE PRESSURE BAR	STANDARD PRESSURE BAR
		kW	HP				
2 KV 6/7 M	1x220-240 V ~	2x1,1	2x1,5	2x7,5	17.0-4.8	6	4
2 KV 6/9 M	1x220-240 V ~	2x1,5	2x2	2x9,4	17.0-4.8	8	5
2 KV 6/7 T	3x400 V ~	2x1,1	2x1,5	2x2,9	17.0-4.8	6	4
2 KV 6/9 T	3x400 V ~	2x1,5	2x2	2x3,6	17.0-4.8	8	5
2 KV 6/11 T	3x400 V ~	2x1,85	2x2,5	2x4,2	17.0-4.8	9.8	6
2 KV 6/15 T	3x400 V ~	2x2,2	2x3	2x6,3	17.0-4.8	13	8

MODEL	A	B	C	D	P	H1	H2	H3	H4	Ø MANIFOLDS		WEIGHT kg
										DNA (suc.)	DNM (del.)	
2 KV 6/7 M	798	500	500	560	108	1021	125	316	580	2"	2"	116
2 KV 6/9 M	798	500	500	560	108	1085	125	380	580	2"	2"	121
2 KV 6/7 T	798	500	500	560	108	1021	125	316	580	2"	2"	121
2 KV 6/9 T	798	500	500	560	108	1085	125	380	580	2"	2"	126
2 KV 6/11 T	798	500	500	560	108	1149	125	414	580	2"	2"	128
2 KV 6/15 T	798	500	500	560	108	1277	125	572	580	2"	2"	140

2 KV 10 - CIVIL USE PRESSURE BOOSTER SETS

Pumped liquid temperature range: from -15 °C to +70 °C - Maximum ambient temperature: +40 °C - Max flow rate: 28.5 m³/h

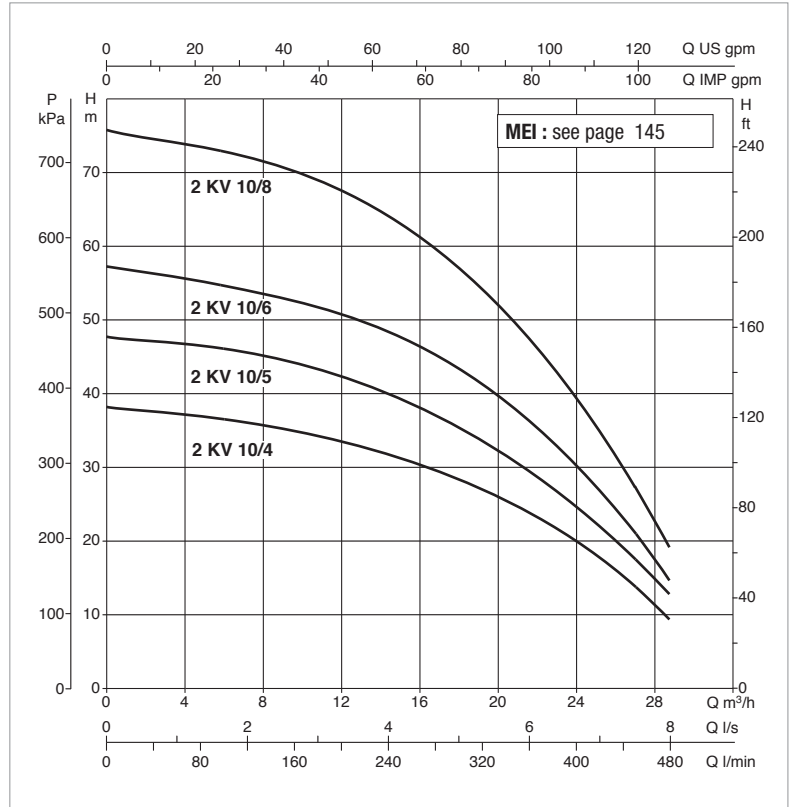
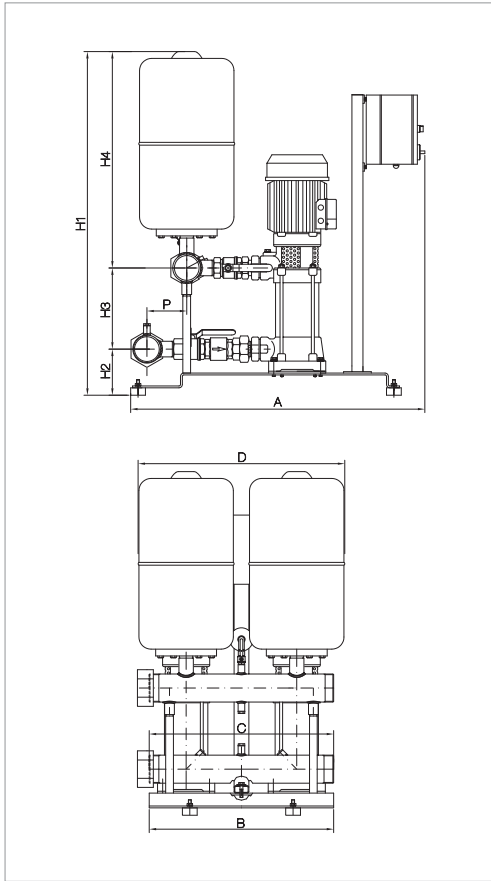

The performance curves are based on kinematic viscosity values = 1 mm²/s and density equivalent to 1000 kg/m³

Curve tolerance according to ISO 9906.

Overall performance taking into account TWO pumps working at the same time.

MODEL	POWER INPUT 50 Hz	P2 NOMINAL		In A	FLOW m ³ /h	MAX OBTAINABLE PRESSURE BAR	STANDARD PRESSURE BAR
		kW	HP				
2 KV 10/4 M	1x220-240 V ~	2x1,1	2x1,5	2x8,3	26.4-6.0	3.8	2.5
2 KV 10/5 M	1x220-240 V ~	2x1,5	2x2	2x10,4	26.4-6.0	4.8	3
2 KV 10/4 T	3x400 V ~	2x1,1	2x1,5	2x3,5	26.4-6.0	3.8	2.5
2 KV 10/5 T	3x400 V ~	2x1,5	2x2	2x3,9	26.4-6.0	4.8	3
2 KV 10/6 T	3x400 V ~	2x1,85	2x2,5	2x5	26.4-6.0	5.5	4
2 KV 10/8 T	3x400 V ~	2x2,2	2x3	2x6,8	26.4-6.0	7.2	5

MODEL	A	B	C	D	P	H1	H2	H3	H4	Ø MANIFOLDS		WEIGHT kg
										DNA (suc.)	DNM (del.)	
2 KV 10/4 M	798	500	500	560	108	925	125	220	580	2 1/2"	2 1/2"	112
2 KV 10/5 M	798	500	500	560	108	957	125	252	580	2 1/2"	2 1/2"	115
2 KV 10/4 T	798	500	500	560	108	925	125	220	580	2 1/2"	2 1/2"	117
2 KV 10/5 T	798	500	500	560	108	957	125	252	580	2 1/2"	2 1/2"	120
2 KV 10/6 T	798	500	500	560	108	989	125	284	580	2 1/2"	2 1/2"	126
2 KV 10/8 T	798	500	500	560	108	1053	125	348	580	2 1/2"	2 1/2"	132

3 KV 3 - CIVIL USE PRESSURE BOOSTER SETS

Pumped liquid temperature range: from -15 °C to +70 °C - Maximum ambient temperature: +40 °C - Max flow rate: 22 m³/h

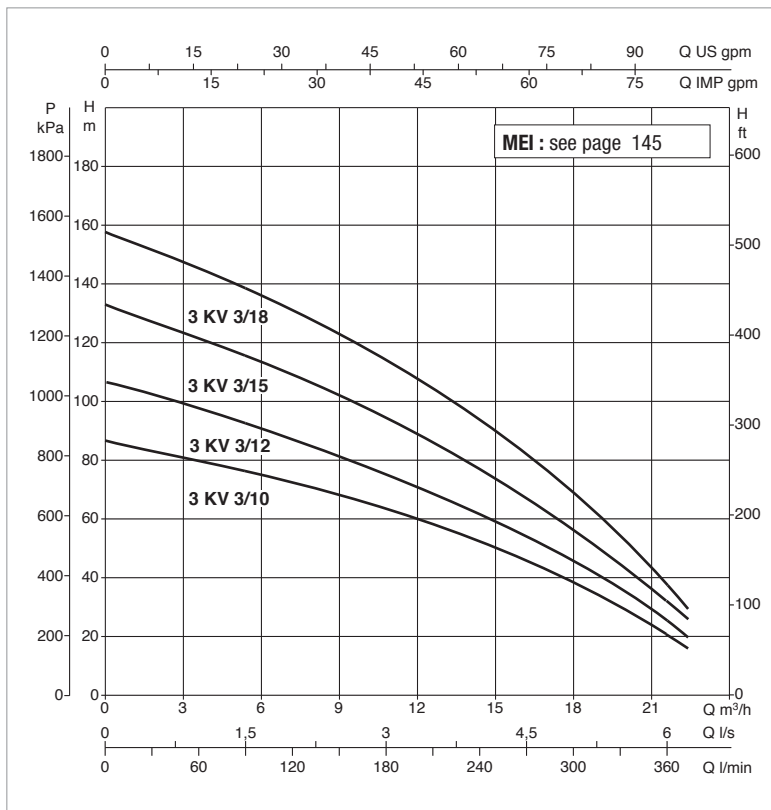
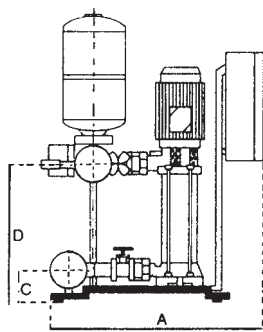
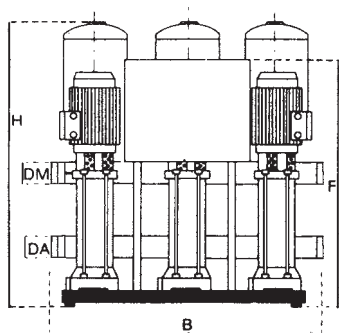

The performance curves are based on kinematic viscosity values = 1 mm²/s and density equivalent to 1000 kg/m³
 Curve tolerance according to ISO 9906.
 Overall performance taking into account THREE pumps working at the same time.

MODEL	POWER INPUT 50 Hz	P2 NOMINAL		In A	FLOW m ³ /h	MAX OBTAINABLE PRESSURE BAR	PRESSURE SWITCH CALIBRATION BAR
		kW	HP				
3 KV 3/10 M	1x220-240 V ~	3x1,1	3x1,5	3x7,8	21.6-5.4	8.2	4÷6
3 KV 3/12 M	1x220-240 V ~	3x1,5	3x2	3x9,6	21.6-5.4	10.2	6÷8
3 KV 3/10 T	3x400 V ~	3x1,1	3x1,5	3x3,2	21.6-5.4	8.2	4÷6
3 KV 3/12 T	3x400 V ~	3x1,5	3x2	3x3,7	21.6-5.4	10.2	6÷8
3 KV 3/15 T	3x400 V ~	3x1,85	3x2,5	3x4,3	21.6-5.4	13	8÷10
3 KV 3/18 T	3x400 V ~	3x2,2	3x3	3x5,8	21.6-5.4	15.8	10÷12

MODEL	A	B	C	D	F	H	Ø MANIFOLDS		WEIGHT kg
							DNA (suc.)	DNM (del.)	
3 KV 3/10 M	710	825	120	532	847	1122	2 1/2"	2 1/2"	156
3 KV 3/12 M	710	825	120	596	911	1186	2 1/2"	2 1/2"	168
3 KV 3/10 T	785	825	120	532	847	1122	2 1/2"	2 1/2"	156
3 KV 3/12 T	785	825	120	596	911	1186	2 1/2"	2 1/2"	165
3 KV 3/15 T	785	825	120	692	1007	1282	2 1/2"	2 1/2"	168
3 KV 3/18 T	785	825	120	788	1181	1378	2 1/2"	2 1/2"	183

3 KV 6 - CIVIL USE PRESSURE BOOSTER SETS

Pumped liquid temperature range: from -15 °C to +70 °C - Maximum ambient temperature: +40 °C - Max flow rate: 27 m³/h

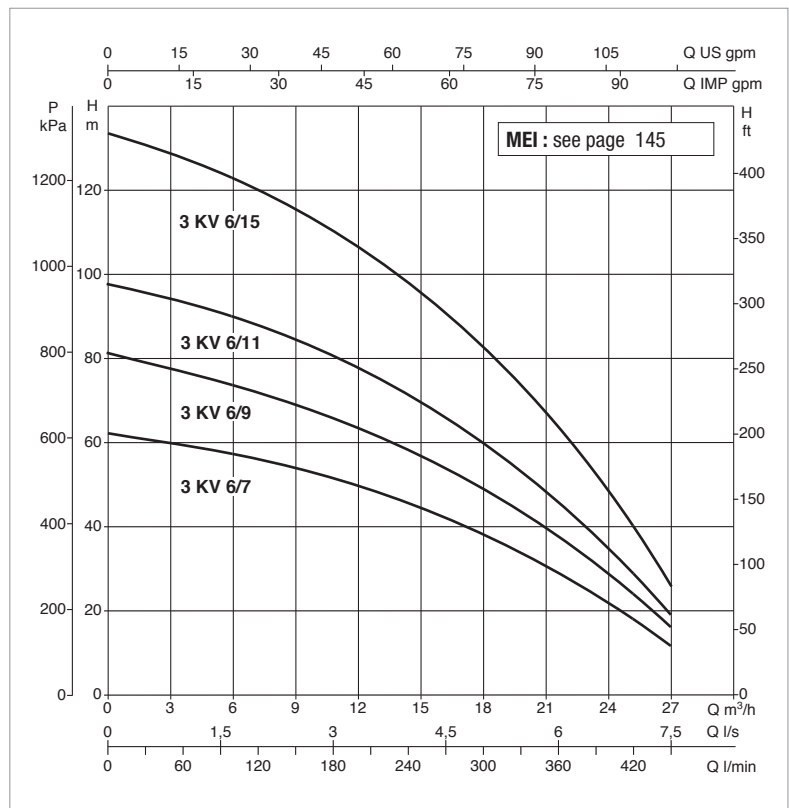
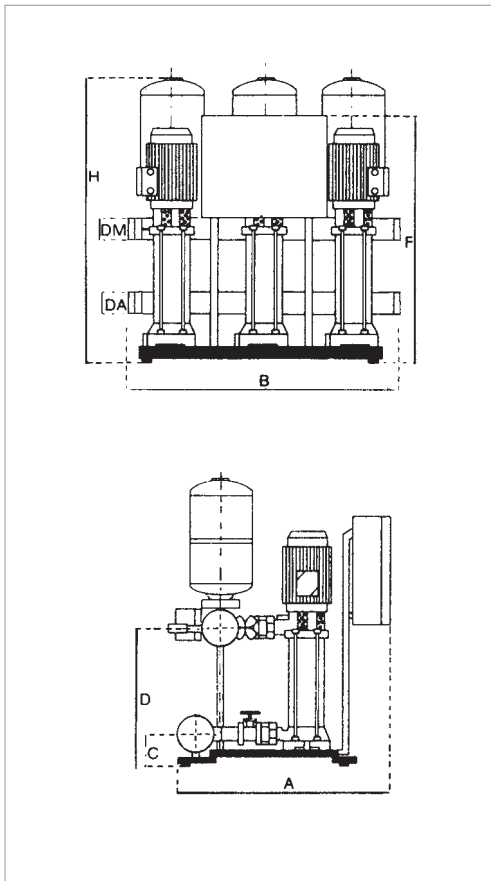

The performance curves are based on kinematic viscosity values = 1 mm²/s and density equivalent to 1000 kg/m³

Curve tolerance according to ISO 9906.

Overall performance taking into account THREE pumps working at the same time.

MODEL	POWER INPUT 50 Hz	P2 NOMINAL		In A	FLOW m ³ /h	PRESSURE SWITCH CALIBRATION BAR	MAX OBTAINABLE PRESSURE BAR
		kW	HP				
3 KV 6/7 M	1x220-240 V ~	3x1,1	3x1,5	3x7,5	25.5-7.2	3÷5	6
3 KV 6/9 M	1x220-240 V ~	3x1,5	3x2	3x9,4	25.5-7.2	5÷7	8
3 KV 6/7 T	3x400 V ~	3x1,1	3x1,5	3x2,9	25.5-7.2	3÷5	6
3 KV 6/9 T	3x400 V ~	3x1,5	3x2	3x3,6	25.5-7.2	5÷7	8
3 KV 6/11 T	3x400 V ~	3x1,85	3x2,5	3x4,2	25.5-7.2	6÷8	9.8
3 KV 6/15 T	3x400 V ~	3x2,2	3x3	3x6,3	25.5-7.2	8÷10	13

MODEL	A	B	C	D	F	H	Ø MANIFOLDS		WEIGHT kg
							DNA (suc.)	DNM (del.)	
3 KV 6/7 M	710	825	120	436	750	1026	2 1/2"	2 1/2"	153
3 KV 6/9 M	710	825	120	500	815	1090	2 1/2"	2 1/2"	162
3 KV 6/7 T	785	825	120	436	750	1026	2 1/2"	2 1/2"	153
3 KV 6/9 T	785	825	120	500	815	1090	2 1/2"	2 1/2"	162
3 KV 6/11 T	785	825	120	664	880	1154	2 1/2"	2 1/2"	170
3 KV 6/15 T	785	825	120	692	1065	1282	2 1/2"	2 1/2"	177

3 KV 10 - CIVIL USE PRESSURE BOOSTER SETS

Pumped liquid temperature range: from -15 °C to +70 °C - Maximum ambient temperature: +40 °C - Max flow rate: 43 m³/h

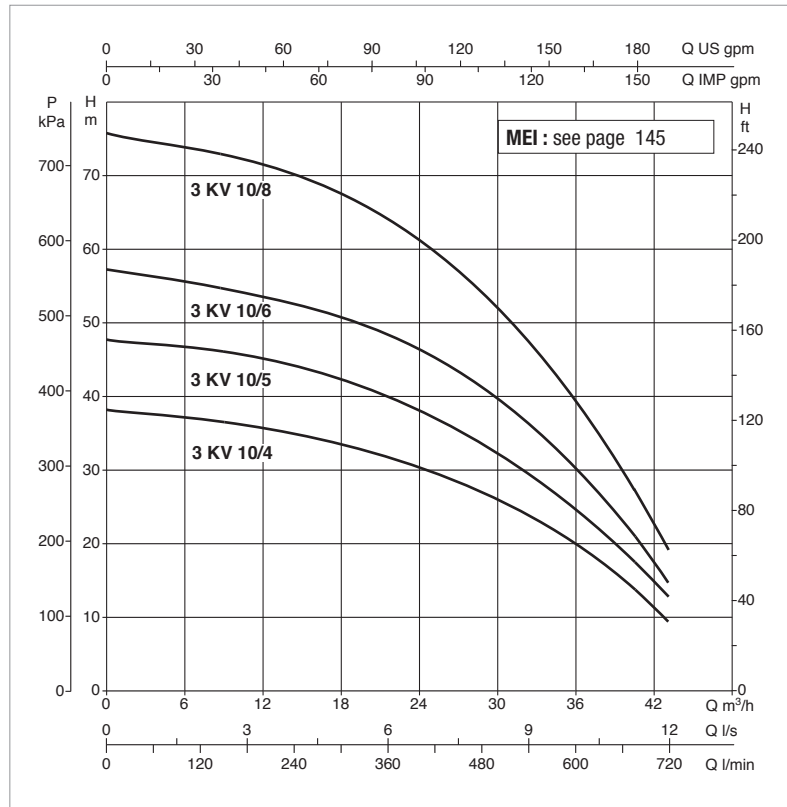
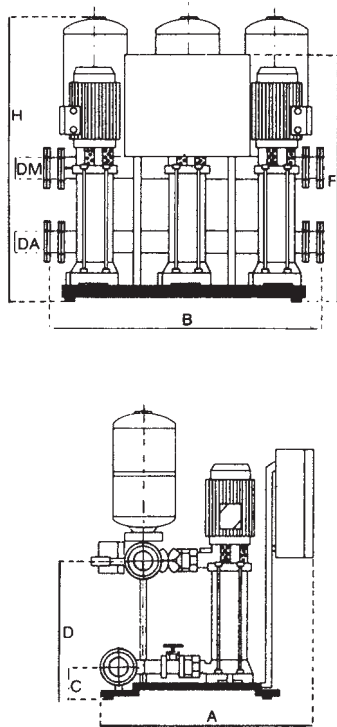

The performance curves are based on kinematic viscosity values = 1 mm²/s and density equivalent to 1000 kg/m³

Curve tolerance according to ISO 9906.

Overall performance taking into account THREE pumps working at the same time.

MODEL	POWER INPUT 50 Hz	P2 NOMINAL		In A	FLOW m ³ /h	PRESSURE SWITCH CALIBRATION BAR	MAX OBTAINABLE PRESSURE BAR
		kW	HP				
3 KV 10/4 M	1x220-240 V ~	3x1,1	3x1,5	3x8,3	39.6-9.0	2÷3	3.8
3 KV 10/5 M	1x220-240 V ~	3x1,5	3x2	3x10,4	39.6-9.0	3÷4	4.8
3 KV 10/4 T	3x400 V ~	3x1,1	3x1,5	3x3,5	39.6-9.0	2÷3	3.8
3 KV 10/5 T	3x400 V ~	3x1,5	3x2	3x3,9	39.6-9.0	3÷4	4.8
3 KV 10/6 T	3x400 V ~	3x1,85	3x2,5	3x5	39.6-9.0	4÷5	5.5
3 KV 10/8 T	3x400 V ~	3x2,2	3x3	3x6,8	39.6-9.0	5÷6	7.2

MODEL	A	B	C	D	F	H	Ø MANIFOLDS		WEIGHT kg
							DNA (suc.)	DNM (del.)	
3 KV 10/4 M	740	940	120	340	655	942	DN 80	DN 80	201
3 KV 10/5 M	740	940	120	372	690	974	DN 80	DN 80	216
3 KV 10/4 T	810	940	120	340	810	942	DN 80	DN 80	201
3 KV 10/5 T	810	940	120	372	810	974	DN 80	DN 80	216
3 KV 10/6 T	810	940	120	404	810	1006	DN 80	DN 80	210
3 KV 10/8 T	810	940	120	468	855	1070	DN 80	DN 80	225

1/2/3/4 NKV

1 - 2 - 3 - 4 VERTICAL AXIS MULTISTAGE CENTRIFUGAL PUMP LIFTING SETS



TECHNICAL DATA

Line voltage: 400V three phase.

Voltage of electric pump: 400V three phase.

Power frequency: 50-60 Hz.

Installation: vertical only.

Operating range: from 4 to 280 m³/h.

Pumped liquid temperature range: from 0 °C to 80 °C.

Maximum ambient temperature: 40°C.

Max pressure: 14bar.

Pumped liquid: clean, free from solids.

Pressure regulation range: 3 to 14 bar.

Protection class: IP55

IE2 motors as standard from 0,75 kW to 5,5 kW - IE3 ≥ 7,5 kW

APPLICATIONS

NKV sets have been designed and manufactured to meet the constant pressure requirements of modern system engineering solutions. The constant pressure adjustment is a requirement in the most varied sectors: Water pipelines, Irrigation, Industry, Hotel, Residential building, Spas. The fundamental concept that has driven our Engineers in developing these pumps sets, was to offer a simple to use, flexible, and extremely reliable product. Differently from traditional fixed speed pumps, inverter driven pumps give the possibility to adapt the performance curve to the needs of the system. In the most classic case, inverter driven pumps are used to maintain constant pressure in the system against variations in the requested flow rate, avoiding pressure fluctuations caused by small flow rate variations.

CONSTRUCTION FEATURES

The NKV sets are built in the standard version with two, three, or four centrifugal electric pumps, completely assembled on galvanised steel base, tested and ready for installation. Complete with isolator and check valves for each pump, suction and delivery manifolds, expansion vessels, pressure sensor, on-pump inverter, protection control unit. (possibility of optional flow sensor for pressure control).

ELECTRIC COMPONENTS SUPPLIED

ELECTRIC CONTROL PANEL

IP 54 metal box electric control panel, installed on the pump base. Direct start up to 7,5 kW included, star-triangle start for higher voltages. AUT-0-MAN operation selectors and operation notification lamps on the front of the panel.

THE CONTROL PANEL PERFORMS THE FOLLOWING FUNCTIONS:

- Abnormal voltage protection.
- Adjustable amperometric protection.
- Dry run protection (without minimum manometer).
- Output phases short circuit protection.
- Overtemperature and overvoltage protection.
- Anti-seizing and anti-freeze functions.
- Pressure sensor fault
- Thermal magnetic protection control unit (simplified connection).
- Pressure sensor on the delivery manifold.

1 NKV 10 - RESIDENTIAL/INDUSTRIAL PRESSURE BOOSTER SETS

Pumped liquid temperature range: from -15 °C to +80 °C - Maximum ambient temperature: 40 °C - Max flow rate: 13 m³/h

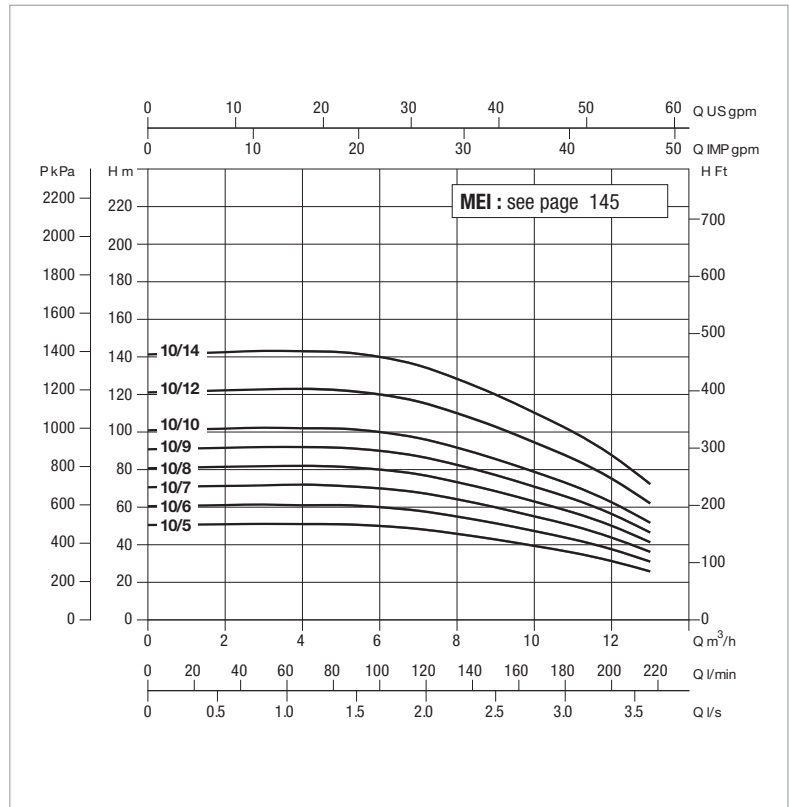
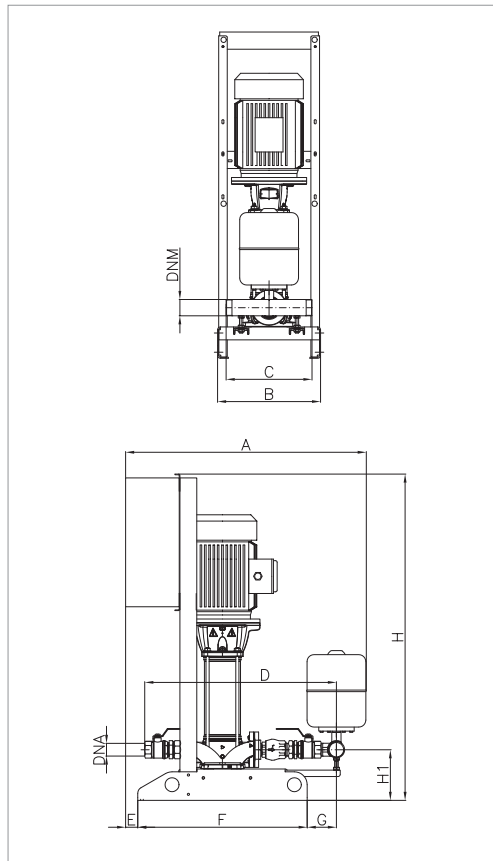

The performance curves are based on kinematic viscosity values = 1 mm²/s and density equivalent to 1000 kg/m³
Curve tolerance according to ISO 9906.

MODEL	50 Hz POWER INPUT	P2 NOMINAL		In A	MAX OBTAINABLE PRESSURE BAR	STANDARD PRESSURE BAR
		kW	HP			
1NKV 10/5 T	3 X 400 V ~	2.2	3	4.7	5	4.0
1NKV 10/6 T	3 X 400 V ~	2.2	3	4.7	6	5.0
1NKV 10/7 T	3 X 400 V ~	3	4	5.8	7	6.0
1NKV 10/8 T	3 X 400 V ~	3	4	5.8	8	7.0
1NKV 10/9 T	3 X 400 V ~	3	4	5.8	9	8.0
1NKV 10/10 T	3 X 400 V ~	4	5.5	7.6	10	8.5
1NKV 10/12 T	3 X 400 V ~	4	5.5	7.6	12	10
1NKV 10/14 T	3 X 400 V ~	5.5	7.5	11	14	12

MODEL	A	B	C	D	E	F	G	H	H1	Ø		WEIGHT kg
										DNA	DNM	
1 NKV 10	1060	480	400	790	60	790	72	1525	226	1 1/2"	2"	118

1 NKV 15 - RESIDENTIAL/INDUSTRIAL PRESSURE BOOSTER SETS

Pumped liquid temperature range: from -15 °C to +80 °C - Maximum ambient temperature: 40 °C - Max flow rate: 24 m³/h

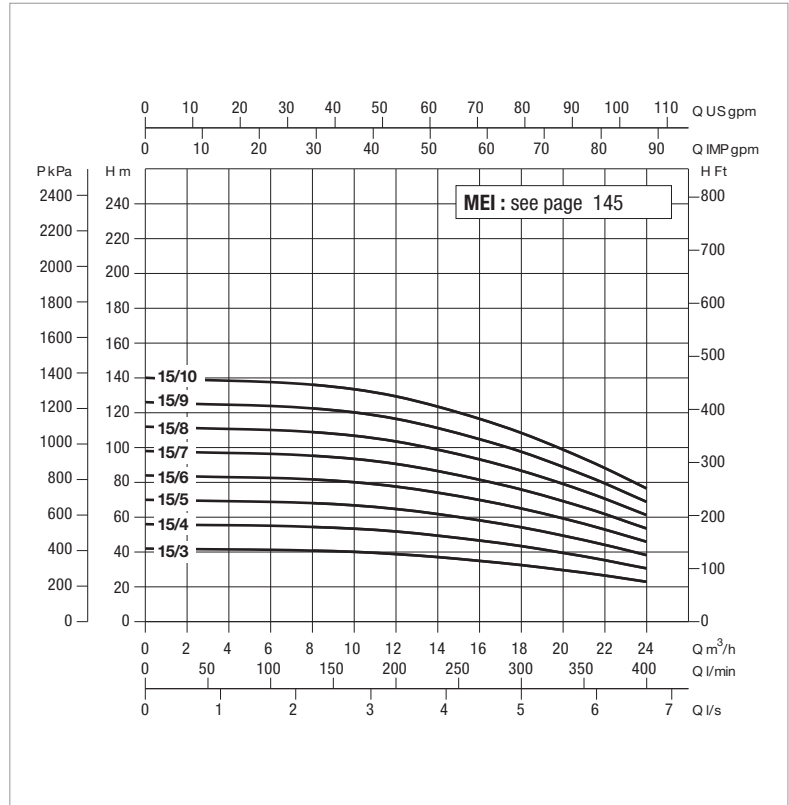
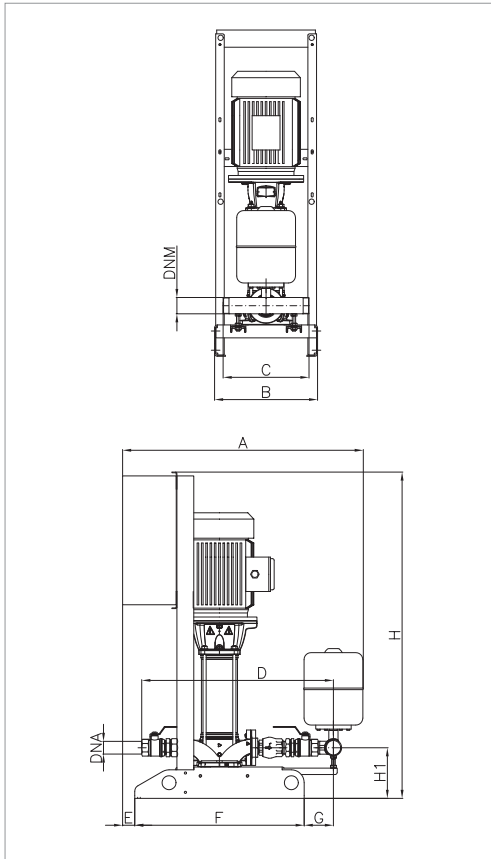

The performance curves are based on kinematic viscosity values = 1 mm²/s and density equivalent to 1000 kg/m³
Curve tolerance according to ISO 9906.

MODEL	50 Hz POWER INPUT	P2 NOMINAL		In A	MAX OBTAINABLE PRESSURE BAR	STANDARD PRESSURE BAR
		kW	HP			
1NKV 15/3 T	3 X 400 V ~	3	4	5.8	4	3.5
1NKV 15/4 T	3 X 400 V ~	4	5.5	7.6	5	4
1NKV 15/5 T	3 X 400 V ~	4	5.5	7.6	6.5	5
1NKV 15/6 T	3 X 400 V ~	5.5	7.5	11	7.7	6.5
1NKV 15/7 T	3 X 400 V ~	5.5	7.5	11	9	8
1NKV 15/8 T	3 X 400 V ~	7.5	10	14.8	10	9
1NKV 15/9 T	3 X 400 V ~	7.5	10	14.8	12	10
1NKV 15/10 T	3 X 400 V ~	11	15	22.4	13	11

MODEL	A	B	C	D	E	F	G	H	H1	Ø		WEIGHT kg
										DNA	DNM	
1 NKV 15	1125	480	400	880	60	790	136	1525	236	2"	2 1/2"	124

1 NKV 20 - RESIDENTIAL/INDUSTRIAL PRESSURE BOOSTER SETS

Pumped liquid temperature range: from -15 °C to +80 °C - Maximum ambient temperature: 40 °C - Max flow rate: 29 m³/h

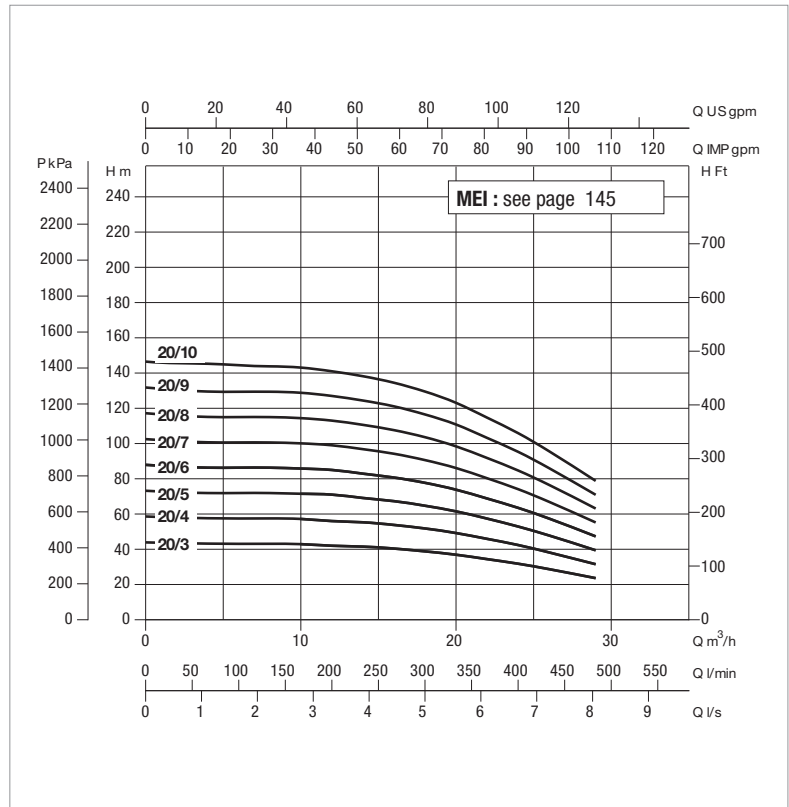
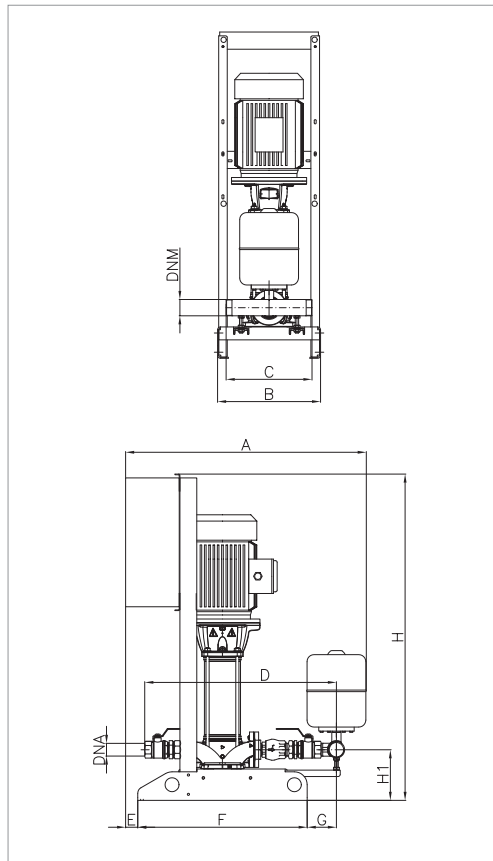

The performance curves are based on kinematic viscosity values = 1 mm²/s and density equivalent to 1000 kg/m³
Curve tolerance according to ISO 9906.

MODEL	50 Hz POWER INPUT	P2 NOMINAL		ln A	MAX OBTAINABLE PRESSURE BAR	STANDARD PRESSURE BAR
		kW	HP			
1NKV 20/3 T	3 X 400 V ~	4	5,5	7,6	4	3
1NKV 20/4 T	3 X 400 V ~	5,5	7,5	11	5,5	4,5
1NKV 20/5 T	3 X 400 V ~	5,5	7,5	11	7	6
1NKV 20/6 T	3 X 400 V ~	7,5	10	14,8	8,5	7
1NKV 20/7 T	3 X 400 V ~	7,5	10	14,8	10	8,5
1NKV 20/8 T	3 X 400 V ~	11	15	22,4	11	9,5
1NKV 20/9 T	3 X 400 V ~	11	15	22,4	12,5	10
1NKV 20/10 T	3 X 400 V ~	11	15	22,4	14	12

MODEL	A	B	C	D	E	F	G	H	H1	Ø		WEIGHT kg
										DNA	DNM	
1 NKV 20	1125	480	400	880	60	790	136	1525	236	2"	2 1/2"	124

1 NKV 32 - RESIDENTIAL/INDUSTRIAL PRESSURE BOOSTER SETS

Pumped liquid temperature range: from -15 °C to +80 °C - Maximum ambient temperature: 40 °C - Max flow rate: 45 m³/h

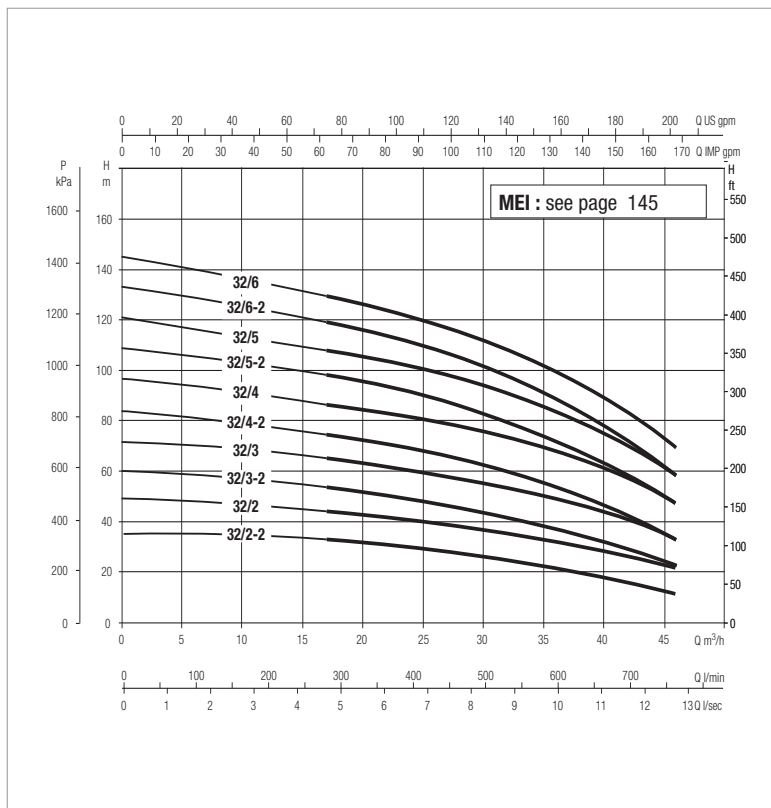
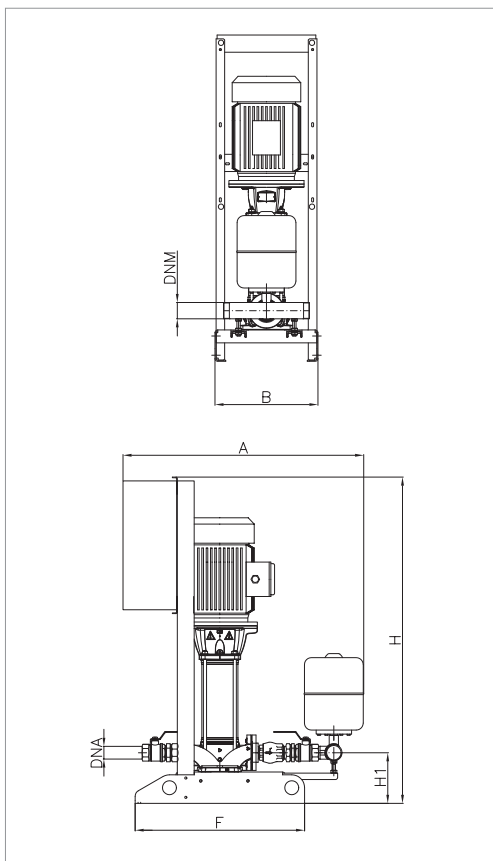

The performance curves are based on kinematic viscosity values = 1 mm²/s and density equivalent to 1000 kg/m³
Curve tolerance according to ISO 9906.

MODEL	50 Hz POWER INPUT	P2 NOMINAL		In A	MAX FLOW RATE m ³ /h	MAX OBTAINABLE PRESSURE BAR	STANDARD PRESSURE BAR
		kW	HP				
1NKV 32/2-2 T 400-50	3x400 50-60Hz	1x4	1x5,5	1x8,1	45	3,6	2,5
1NKV 32/2 T 400-50	3x400 50-60Hz	1x5,5	1x7,5	1x10,4	45	4,8	3,5
1NKV 32/3-2 T 400-50	3x400 50-60Hz	1x5,5	1x7,5	1x10,4	45	6	5
1NKV 32/3 T IE3 400-50	3x400 50-60Hz	1x7,5	1x10	1x13,4	45	7,3	6
1NKV 32/4-2 T IE3 400-50	3x400 50-60Hz	1x7,5	1x10	1x13,4	45	8,4	7
1NKV 32/4 T IE3 400-50	3x400 50-60Hz	1x11	1x15	1x19,4	45	9,8	8,5
1NKV 32/5-2 T IE3 400-50	3x400 50-60Hz	1x11	1x15	1x19,4	45	10,9	9
1NKV 32/5 T IE3 400-50	3x400 50-60Hz	1x15	1x20	1x26,5	45	12	11
1NKV 32/6-2 T IE3 400-50	3x400 50-60Hz	1x15	1x20	1x26,5	45	13,4	12
1NKV 32/6 T IE3 400-50	3x400 50-60Hz	1x15	1x20	1x26,5	45	14,6	13

MODEL	A	B	F	H	H1	Ø		PACKING DIMENSIONS
						DNA	DNM	
1NKV 32/2-2 T 400-50	1316	535	890	1043	271	2" 1/2	80	1000x1400x2200
1NKV 32/2 T 400-50	1316	535	890	1280	271	2" 1/2	80	1000x1400x2200
1NKV 32/3-2 T 400-50	1316	535	890	1362	271	2" 1/2	80	1000x1400x2200
1NKV 32/3 T IE3 400-50	1316	535	890	1362	271	2" 1/2	80	1000x1400x2200
1NKV 32/4-2 T IE3 400-50	1316	535	890	1444	271	2" 1/2	80	1000x1400x2200
1NKV 32/4 T IE3 400-50	1316	535	890	1579	271	2" 1/2	80	1000x1400x2200
1NKV 32/5-2 T IE3 400-50	1316	535	890	1661	271	2" 1/2	80	1000x1400x2200
1NKV 32/5 T IE3 400-50	1316	535	890	1661	271	2" 1/2	80	1000x1400x2200
1NKV 32/6-2 T IE3 400-50	1316	535	890	1743	271	2" 1/2	80	1000x1400x2200
1NKV 32/6 T IE3 400-50	1316	535	890	1743	271	2" 1/2	80	1000x1400x2200

For the weights contact our sales network.

1 NKV 45 - RESIDENTIAL/INDUSTRIAL PRESSURE BOOSTER SETS

Pumped liquid temperature range: from -15 °C to +80 °C - Maximum ambient temperature: 40 °C - Max flow rate: 70 m³/h

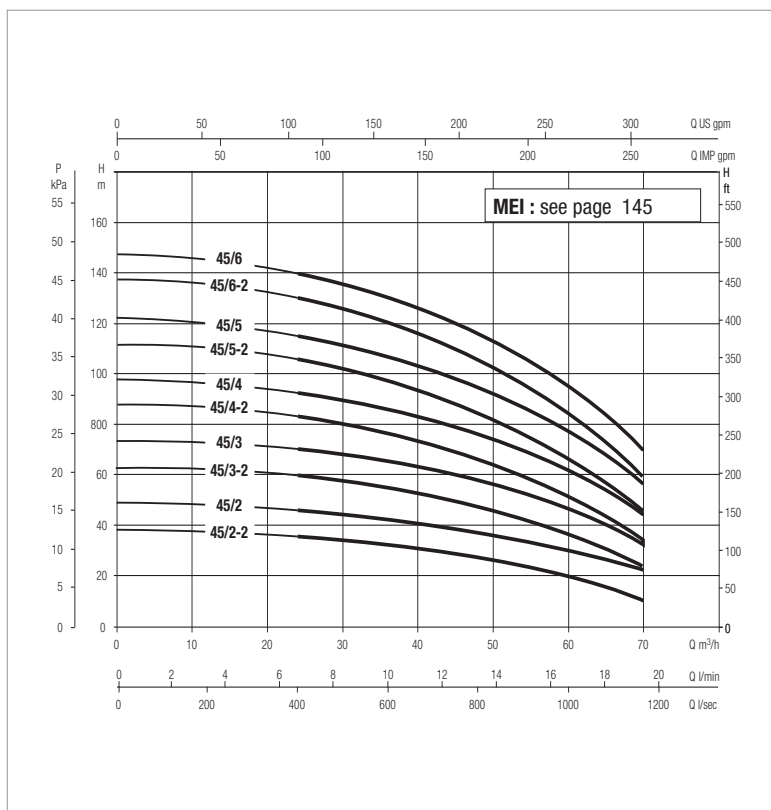
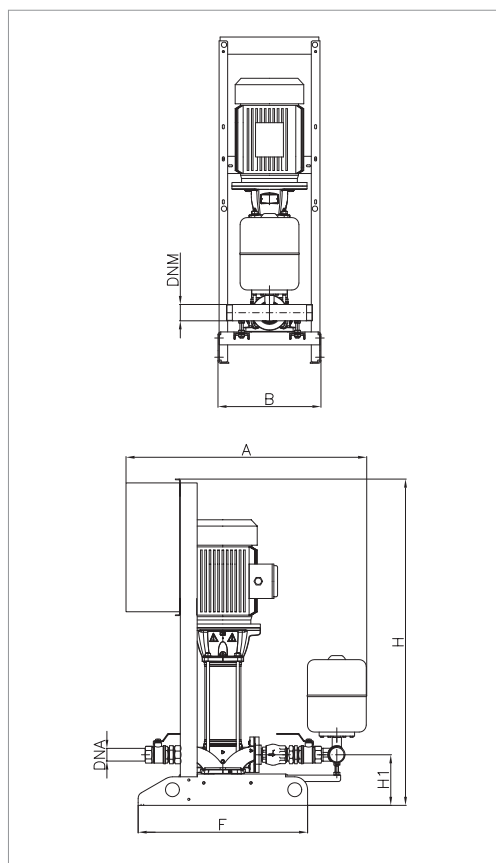

The performance curves are based on kinematic viscosity values = 1 mm²/s and density equivalent to 1000 kg/m³
Curve tolerance according to ISO 9906.

MODEL	50 Hz POWER INPUT	P2 NOMINAL		In A	MAX FLOW RATE m ³ /h	MAX OBTAINABLE PRESSURE BAR	STANDARD PRESSURE BAR
		kW	HP				
1NKV 45/2-2 T 400-50	3x400 50-60Hz	1x5,5	1x7,5	1x10,4	70	3,8	2,5
1NKV 45/2 T IE3 400-50	3x400 50-60Hz	1x7,5	1x10	1x13,4	70	4,8	3,5
1NKV 45/3-2 T IE3 400-50	3x400 50-60Hz	1x11	1x15	1x19,4	70	6,3	5
1NKV 45/3 T IE3 400-50	3x400 50-60Hz	1x11	1x15	1x19,4	70	7,3	6
1NKV 45/4-2 T IE3 400-50	3x400 50-60Hz	1x15	1x20	1x26,5	70	8,7	7
1NKV 45/4 T IE3 400-50	3x400 50-60Hz	1x15	1x20	1x26,5	70	9,7	8
1NKV 45/5-2 T IE3 400-50	3x400 50-60Hz	1x18,5	1x25	1x32	70	11,2	10
1NKV 45/5 T IE3 400-50	3x400 50-60Hz	1x18,5	1x25	1x32	70	12,2	11
1NKV 45/6-2 T IE3 400-50	3x400 50-60Hz	1x22	1x30	1x38	70	13,7	12
1NKV 45/6 T IE3 400-50	3x400 50-60Hz	1x22	1x30	1x38	70	14,7	13

MODEL	A	B	F	H	H1	Ø		PACKING DIMENSIONS
						DNA	DNM	
1NKV 45/2-2 T 400-50	1349	535	890	1315	306	3"	100	1000x1400x2200
1NKV 45/2 T IE3 400-50	1349	535	890	1315	306	3"	100	1000x1400x2200
1NKV 45/3-2 T IE3 400-50	1349	535	890	1532	306	3"	100	1000x1400x2200
1NKV 45/3 T IE3 400-50	1349	535	890	1532	306	3"	100	1000x1400x2200
1NKV 45/4-2 T IE3 400-50	1349	535	890	1614	306	3"	100	1000x1400x2200
1NKV 45/4 T IE3 400-50	1349	535	890	1614	306	3"	100	1000x1400x2200
1NKV 45/5-2 T IE3 400-50	1349	535	890	1751	306	3"	100	1000x1400x2200
1NKV 45/5 T IE3 400-50	1349	535	890	1751	306	3"	100	1000x1400x2200
1NKV 45/6-2 T IE3 400-50	1349	535	890	1853	306	3"	100	1000x1400x2200
1NKV 45/6 T IE3 400-50	1349	535	890	1853	306	3"	100	1000x1400x2200

For the weights contact our sales network.

2 NKV 10 - RESIDENTIAL/INDUSTRIAL PRESSURE BOOSTER SETS

Pumped liquid temperature range: from -15 °C to +80 °C - Maximum ambient temperature: 40 °C - Max flow rate: 26 m³/h

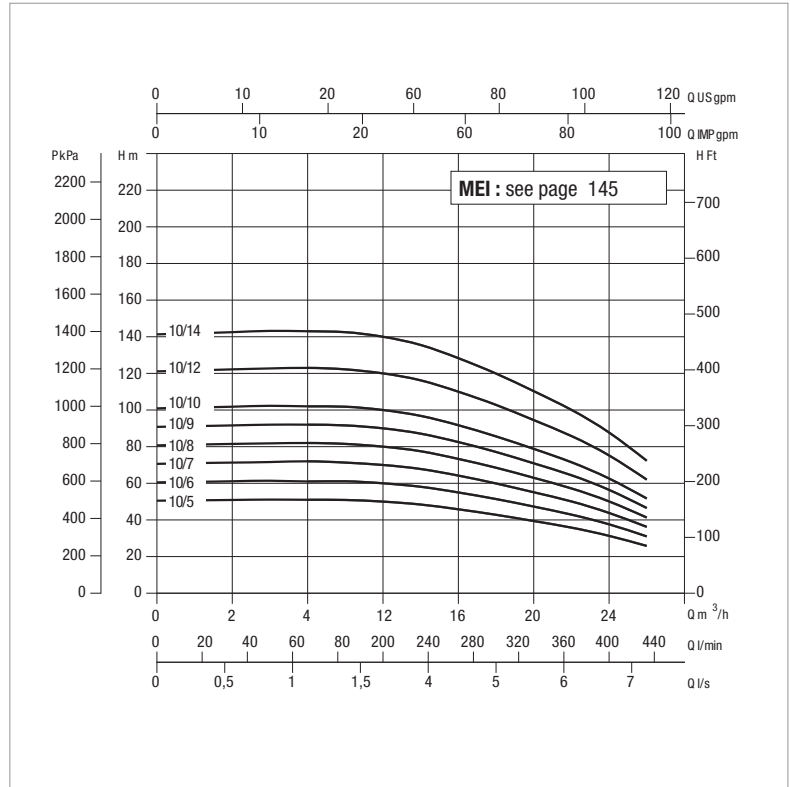
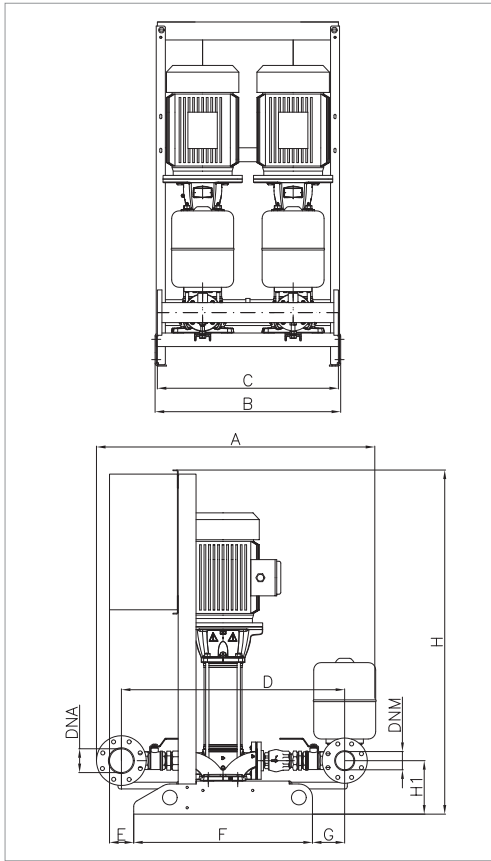

The performance curves are based on kinematic viscosity values = 1 mm²/s and density equal to 1000 kg/m³.
Curve tolerance according to ISO 9906.

Overall performance taking into account TWO pumps working at the same time.

MODEL	50 Hz POWER INPUT	P2 NOMINAL		In A	MAX OBTAINABLE PRESSURE BAR	STANDARD PRESSURE BAR
		kW	HP			
2NKV 10/5 T	3 X 400 V ~	2x2,2	2x3	2x 4,7	5	4,0
2NKV 10/6 T	3 X 400 V ~	2x2,2	2x3	2x 4,7	6	5,0
2NKV 10/7 T	3 X 400 V ~	2x3	2x4	2x 5,8	7	6,0
2NKV 10/8 T	3 X 400 V ~	2x3	2x4	2x 5,8	8	7,0
2NKV 10/9 T	3 X 400 V ~	2x3	2x4	2x 5,8	9	8,0
2NKV 10/10 T	3 X 400 V ~	2x4	2x5,5	2x 7,6	10	8,5
2NKV 10/12 T	3 X 400 V ~	2x4	2x5,5	2x 7,6	12	10
2NKV 10/14 T	3 X 400 V ~	2x5,5	2x7,5	2x 11	14	12

MODEL	A	B	C	D	E	F	G	H	H1	Ø		WEIGHT kg
										DNA	DNM	
2 NKV 10	1120	820	800	860	110	790	80	1525	226	2 1/2"	2 1/2"	123

2 NKV 15 - RESIDENTIAL/INDUSTRIAL PRESSURE BOOSTER SETS

Pumped liquid temperature range: from -15 °C to +80 °C - Maximum ambient temperature: 40 °C - Max flow rate: 48 m³/h

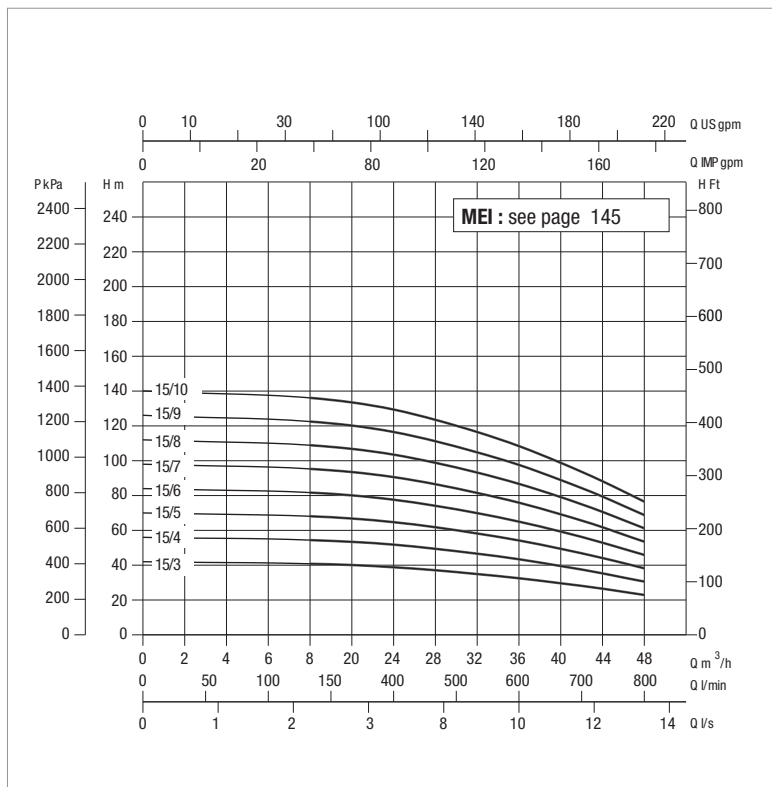
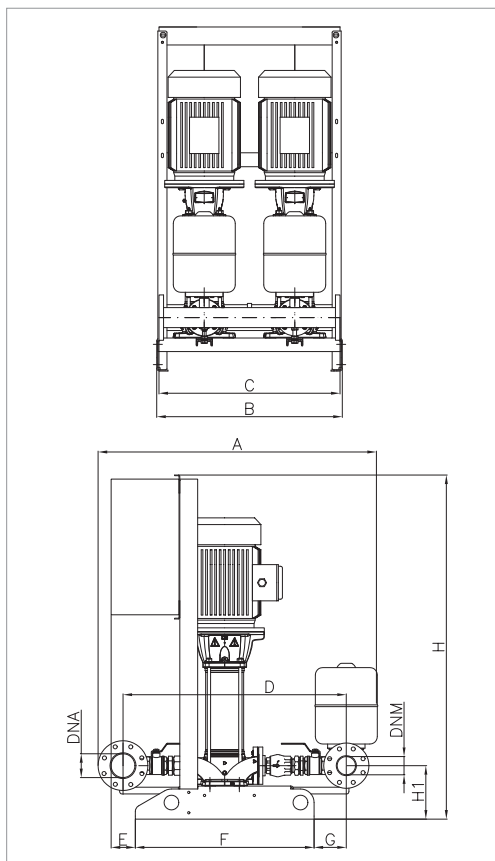

The performance curves are based on kinematic viscosity values = 1 mm²/s and density equal to 1000 kg/m³.
Curve tolerance according to ISO 9906.

Overall performance taking into account TWO pumps working at the same time.

MODEL	50 Hz POWER INPUT	P2 NOMINAL		In A	MAX OBTAINABLE PRESSURE BAR	STANDARD PRESSURE BAR
		KW	HP			
2NKV 15/3 T	3 X 400 V ~	2x3	2x4	2x5,8	4	3,5
2NKV 15/4 T	3 X 400 V ~	2x4	2x5,5	2x7,6	5	4
2NKV 15/5 T	3 X 400 V ~	2x4	2x5,5	2x7,6	6,5	5
2NKV 15/6 T	3 X 400 V ~	2x5,5	2x7,5	2x11	7,7	6,5
2NKV 15/7 T	3 X 400 V ~	2x5,5	2x7,5	2x11	9	8
2NKV 15/8 T	3 X 400 V ~	2x7,5	2x10	2x14,8	10	9
2NKV 15/9 T	3 X 400 V ~	2x7,5	2x10	2x14,8	12	10
2NKV 15/10 T	3 X 400 V ~	2x11	2x15	2x22,4	13	11

MODEL	A	B	C	D	E	F	G	H	H1	Ø		WEIGHT kg
										DNA	DNM	
2 NKV 15	1265	820	800	975	110	790	145	1525	236	DN 100	DN 80	129

2 NKV 20 - RESIDENTIAL/INDUSTRIAL PRESSURE BOOSTER SETS

Pumped liquid temperature range: from -15 °C to +80 °C - Maximum ambient temperature: 40 °C - Max flow rate: 58 m³/h

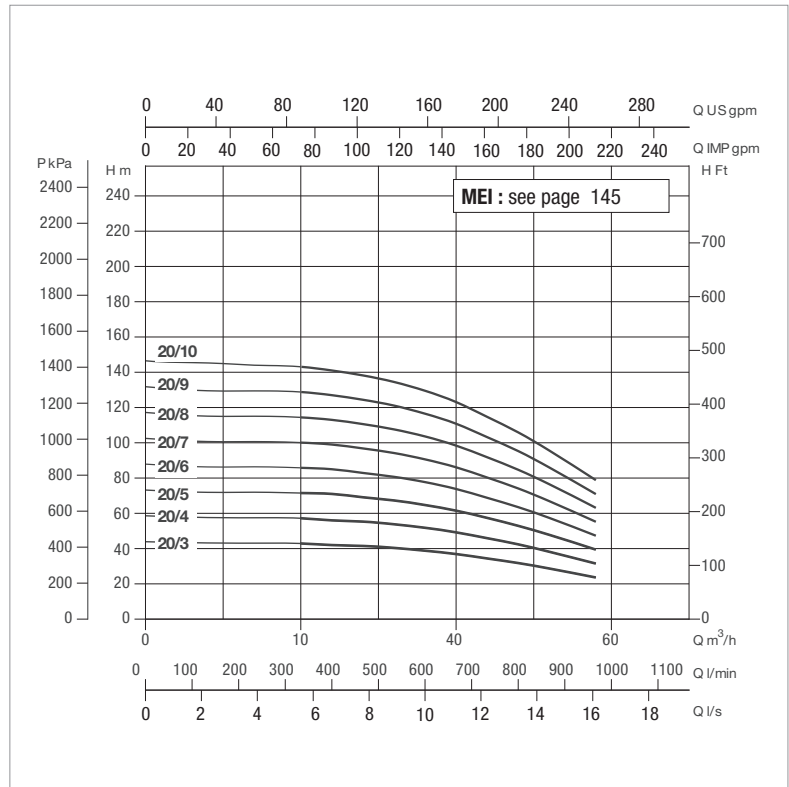
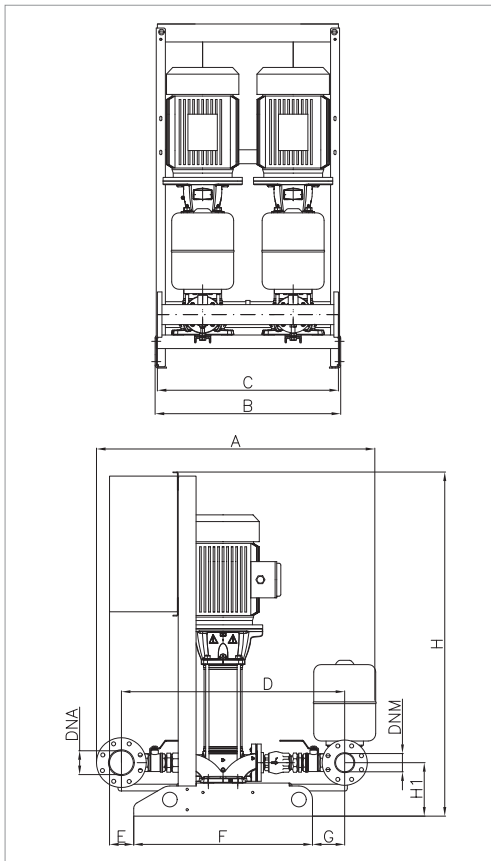

The performance curves are based on kinematic viscosity values = 1 mm²/s and density equal to 1000 kg/m³.
Curve tolerance according to ISO 9906.

Overall performance taking into account TWO pumps working at the same time.

MODEL	50 Hz POWER INPUT	P2 NOMINAL		In A	MAX OBTAINABLE PRESSURE BAR	STANDARD PRESSURE BAR
		kW	HP			
2NKV 20/3 T	3 X 400 V ~	2x4	2x5,5	2x7,6	4	3
2NKV 20/4 T	3 X 400 V ~	2x5,5	2x7,5	2x11	5,5	4,5
2NKV 20/5 T	3 X 400 V ~	2x5,5	2x7,5	2x11	7	6
2NKV 20/6 T	3 X 400 V ~	2x7,5	2x10	2x14,8	8,5	7
2NKV 20/7 T	3 X 400 V ~	2x7,5	2x10	2x14,8	10	8,5
2NKV 20/8 T	3 X 400 V ~	2x11	2x15	2x22,4	11	9,5
2NKV 20/9 T	3 X 400 V ~	2x11	2x15	2x22,4	12,5	10
2NKV 20/10 T	3 X 400 V ~	2x11	2x15	2x22,4	14	12

MODEL	A	B	C	D	E	F	G	H	H1	Ø		WEIGHT kg
										DNA	DNM	
2 NKV 20	1265	820	800	975	110	790	145	1525	236	DN 100	DN 80	129

2 NKV 32 - RESIDENTIAL/INDUSTRIAL PRESSURE BOOSTER SETS

Pumped liquid temperature range: from -15 °C to +80 °C - Maximum ambient temperature: 40 °C - Max flow rate: 90 m³/h

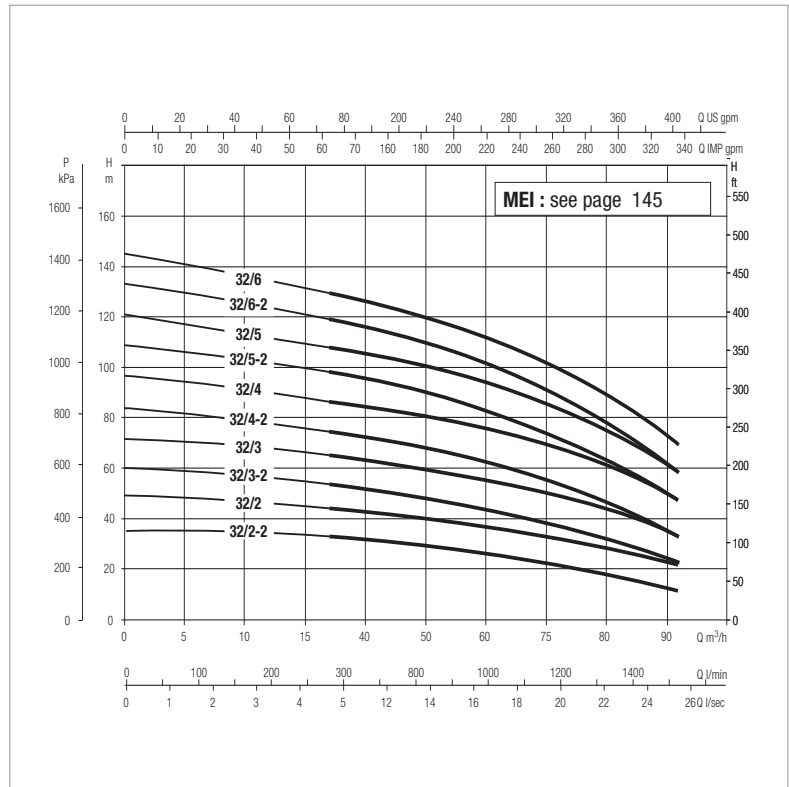
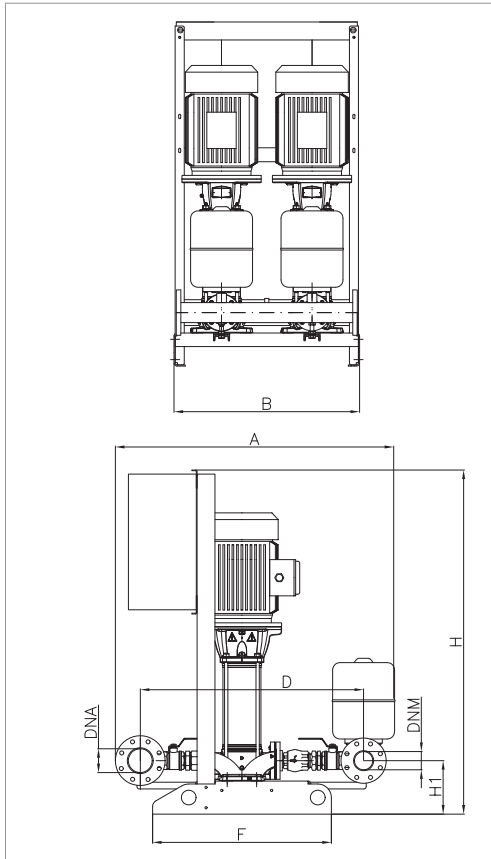

The performance curves are based on kinematic viscosity values = 1 mm²/s and density equal to 1000 kg/m³.
Curve tolerance according to ISO 9906.

Overall performance taking into account TWO pumps working at the same time.

MODEL	50 Hz POWER INPUT	P2 NOMINAL		In A	MAX FLOW RATE m ³ /h	MAX OBTAINABLE PRESSURE BAR	STANDARD PRESSURE BAR
		kW	HP				
2NKV 32/2-2 T 400-50	3x400 50-60Hz	2x4	2x5,5	2x8,1	90	3,6	2,5
2NKV 32/2 T 400-50	3x400 50-60Hz	2x5,5	2x7,5	2x10,4	90	4,8	3,5
2NKV 32/3-2 T 400-50	3x400 50-60Hz	2x5,5	2x7,5	2x10,4	90	6	5
2NKV 32/3 T IE3 400-50	3x400 50-60Hz	2x7,5	2x10	2x13,4	90	7,3	6
2NKV 32/4-2 T IE3 400-50	3x400 50-60Hz	2x7,5	2x10	2x13,4	90	8,4	7
2NKV 32/4 T IE3 400-50	3x400 50-60Hz	2x11	2x15	2x19,4	90	9,8	8,5
2NKV 32/5-2 T IE3 400-50	3x400 50-60Hz	2x11	2x15	2x19,4	90	10,9	9
2NKV 32/5 T IE3 400-50	3x400 50-60Hz	2x15	2x20	2x26,5	90	12	11
2NKV 32/6-2 T IE3 400-50	3x400 50-60Hz	2x15	2x20	2x26,5	90	13,4	12
2NKV 32/6 T IE3 400-50	3x400 50-60Hz	2x15	2x20	2x26,5	90	14,6	13

MODEL	A	B	D	F	H	H1	Ø		PACKING DIMENSIONS
							DNA	DNM	
2NKV 32/2-2 T 400-50	1557	1025	1293	890	1043	271	125	100	1400x1800x2200
2NKV 32/2 T 400-50	1557	1025	1293	890	1280	271	125	100	1400x1800x2200
2NKV 32/3-2 T 400-50	1557	1025	1293	890	1362	271	125	100	1400x1800x2200
2NKV 32/3 T IE3 400-50	1557	1025	1293	890	1362	271	125	100	1400x1800x2200
2NKV 32/4-2 T IE3 400-50	1557	1025	1293	890	1444	271	125	100	1400x1800x2200
2NKV 32/4 T IE3 400-50	1557	1025	1293	890	1579	271	125	100	1400x1800x2200
2NKV 32/5-2 T IE3 400-50	1557	1025	1293	890	1661	271	125	100	1400x1800x2200
2NKV 32/5 T IE3 400-50	1557	10253	1293	890	1661	271	125	100	1400x1800x2200
2NKV 32/6-2 T IE3 400-50	1557	1025	1293	890	1743	271	125	100	1400x1800x2200
2NKV 32/6 T IE3 400-50	1557	1025	1293	890	1743	271	125	100	1400x1800x2200

For the weights contact our sales network.

2 NKV 45 - RESIDENTIAL/INDUSTRIAL PRESSURE BOOSTER SETS

Pumped liquid temperature range: from -15 °C to +80 °C - Maximum ambient temperature: 40 °C - Max flow rate: 140 m³/h

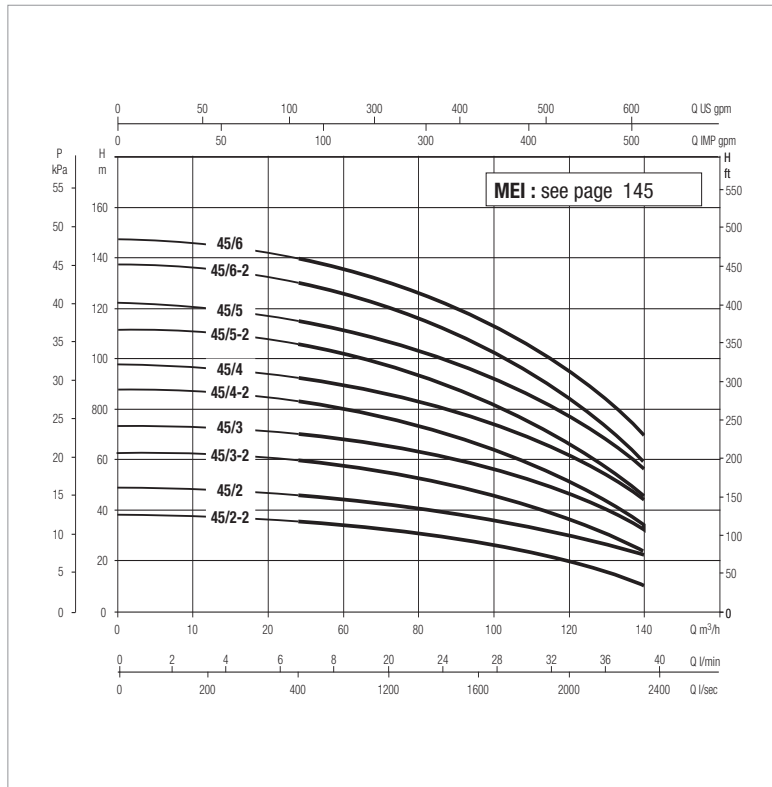
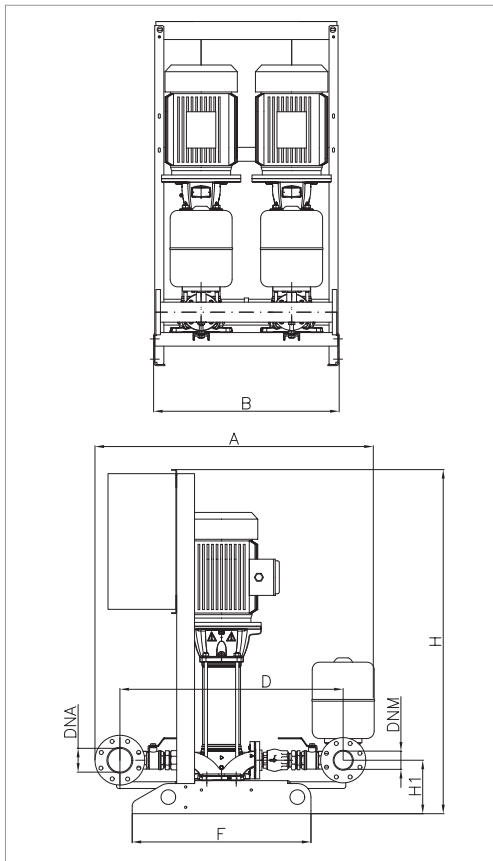

The performance curves are based on kinematic viscosity values = 1 mm²/s and density equal to 1000 kg/m³.
Curve tolerance according to ISO 9906.

Overall performance taking into account TWO pumps working at the same time.

MODEL	50 Hz POWER INPUT	P2 NOMINAL		In A	MAX FLOW RATE m ³ /h	MAX OBTAINABLE PRESSURE BAR	STANDARD PRESSURE BAR
		kW	HP				
2NKV 45/2-2 T 400-50	3x400 50-60Hz	2x5,5	2x7,5	2x10,4	140	3,8	2,5
2NKV 45/2 T IE3 400-50	3x400 50-60Hz	2x7,5	2x10	2x13,4	140	4,8	3,5
2NKV 45/3-2 T IE3 400-50	3x400 50-60Hz	2x11	2x15	2x19,4	140	6,3	5
2NKV 45/3 T IE3 400-50	3x400 50-60Hz	2x11	2x15	2x19,4	140	7,3	6
2NKV 45/4-2 T IE3 400-50	3x400 50-60Hz	2x15	2x20	2x26,5	140	8,7	7
2NKV 45/4 T IE3 400-50	3x400 50-60Hz	2x15	2x20	2x26,5	140	9,7	8
2NKV 45/5-2 T IE3 400-50	3x400 50-60Hz	2x18,5	2x25	2x32	140	11,2	10
2NKV 45/5 T IE3 400-50	3x400 50-60Hz	2x18,5	2x25	2x32	140	12,2	11
2NKV 45/6-2 T IE3 400-50	3x400 50-60Hz	2x22	2x30	2x38	140	13,7	12
2NKV 45/6 T IE3 400-50	3x400 50-60Hz	2x22	2x30	2x38	140	14,7	13

MODEL	A	B	D	F	H	H1	Ø		PACKING DIMENSIONS
							DNA	DNM	
2NKV 45/2-2 T 400-50	1622	1000	1340	890	1295	306	150	125	1400x1800x2200
2NKV 45/2 T IE3 400-50	1622	1000	1340	890	1295	306	150	125	1400x1800x2200
2NKV 45/3-2 T IE3 400-50	1622	1000	1340	890	1512	306	150	125	1400x1800x2200
2NKV 45/3 T IE3 400-50	1622	1000	1340	890	1512	306	150	125	1400x1800x2200
2NKV 45/4-2 T IE3 400-50	1622	1000	1340	890	1594	306	150	125	1400x1800x2200
2NKV 45/4 T IE3 400-50	1622	1000	1340	890	1594	306	150	125	1400x1800x2200
2NKV 45/5-2 T IE3 400-50	1622	1000	1340	890	1731	306	150	125	1400x1800x2200
2NKV 45/5 T IE3 400-50	1622	1000	1340	890	1731	306	150	125	1400x1800x2200
2NKV 45/6-2 T IE3 400-50	1622	1000	1340	890	1833	306	150	125	1400x1800x2200
2NKV 45/6 T IE3 400-50	1622	1000	1340	890	1833	306	150	125	1400x1800x2200

For the weights contact our sales network.

3 NKV 10 - RESIDENTIAL/INDUSTRIAL PRESSURE BOOSTER SETS

Pumped liquid temperature range: from -15 °C to +80 °C - Maximum ambient temperature: 40 °C - Max flow rate: 39 m³/h

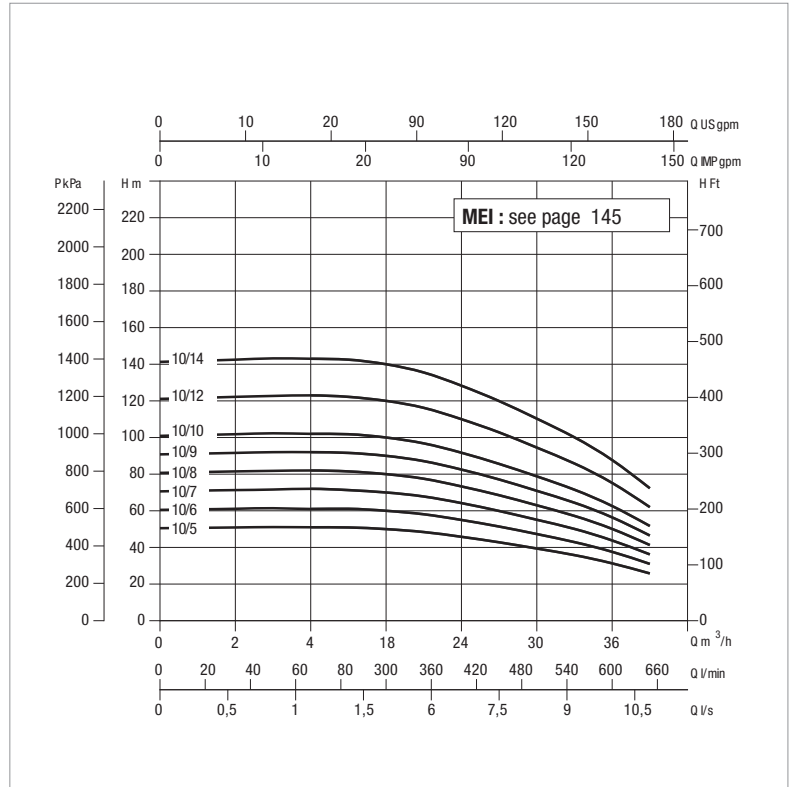
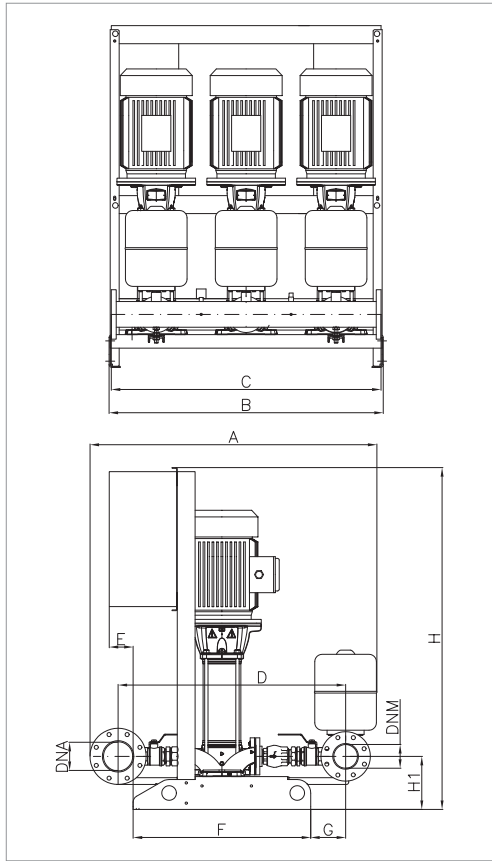

The performance curves are based on kinematic viscosity values = 1 mm²/s and density equal to 1000 kg/m³.
Curve tolerance according to ISO 9906.

Overall performance taking into account THREE pumps working at the same time.

MODEL	50 Hz POWER INPUT	P2 NOMINAL		In A	MAX OBTAINABLE PRESSURE BAR	STANDARD PRESSURE BAR
		KW	HP			
3NKV 10/5 T	3 X 400 V ~	3x2,2	3x3	3x 4,7	5	4,0
3NKV 10/6 T	3 X 400 V ~	2x2,2	3x3	3x 4,7	6	5,0
3NKV 10/7 T	3 X 400 V ~	3x3	3x4	3x 5,8	7	6,0
3NKV 10/8 T	3 X 400 V ~	3x3	3x4	3x 5,8	8	7,0
3NKV 10/9 T	3 X 400 V ~	3x3	3x4	3x 5,8	9	8,0
3NKV 10/10 T	3 X 400 V ~	3x4	3x5,5	3x 7,6	10	8,5
3NKV 10/12 T	3 X 400 V ~	3x4	3x5,5	3x 7,6	12	10
3NKV 10/14 T	3 X 400 V ~	3x5,5	3x7,5	3x 11	14	12

MODEL	A	B	C	D	E	F	G	H	H1	Ø		WEIGHT kg
										DNA	DNM	
3 NKV 10	1125	1220	1200	870	110	790	86	1525	226	DN 0	DN 80	134

3 NKV 15 - RESIDENTIAL/INDUSTRIAL PRESSURE BOOSTER SETS

Pumped liquid temperature range: from -15 °C to +80 °C - Maximum ambient temperature: 40 °C - Max flow rate: 72 m³/h

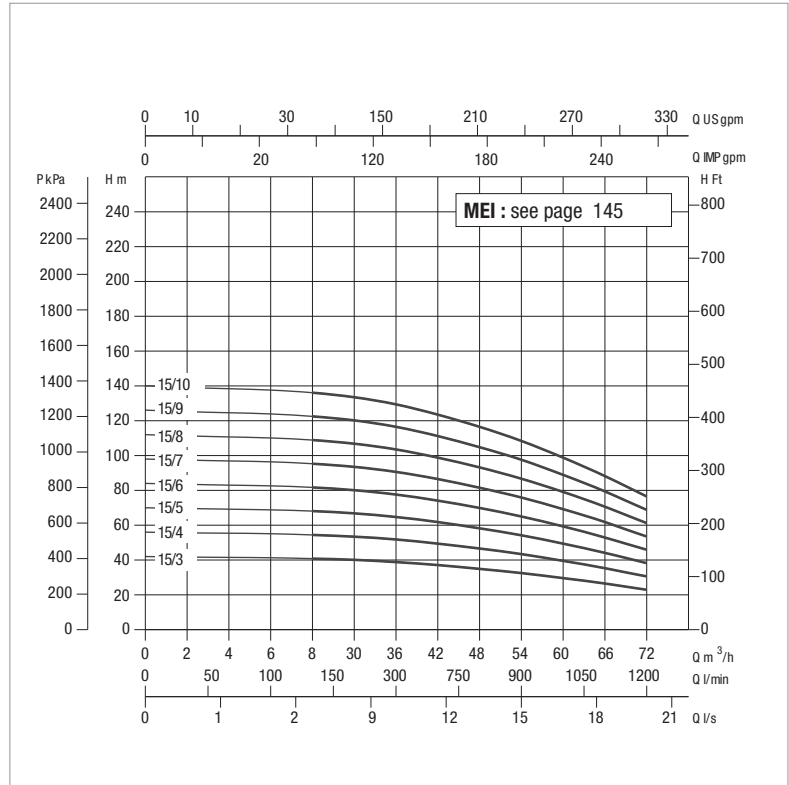
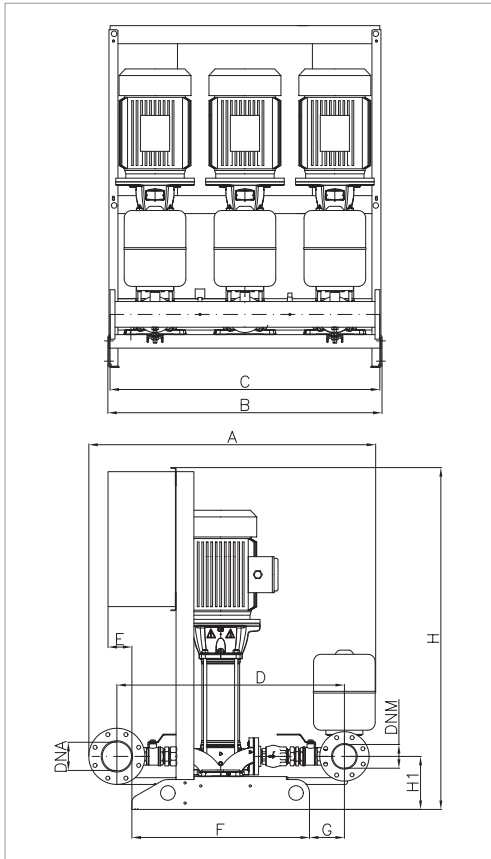

The performance curves are based on kinematic viscosity values = 1 mm²/s and density equal to 1000 kg/m³.
Curve tolerance according to ISO 9906.

Overall performance taking into account THREE pumps working at the same time.

MODEL	50 Hz POWER INPUT	P2 NOMINAL		In A	MAX OBTAINABLE PRESSURE BAR	STANDARD PRESSURE BAR
		kW	HP			
3NKV 15/3 T	3 X 400 V ~	3x 3	3x 4	3x 5,8	4	3,5
3NKV 15/4 T	3 X 400 V ~	3x 4	3x 5,5	3x 7,6	5	4
3NKV 15/5 T	3 X 400 V ~	3x 4	3x 5,5	3x 7,6	6,5	5
3NKV 15/6 T	3 X 400 V ~	3x 5,5	3x 7,5	3x 11	7,7	6,5
3NKV 15/7 T	3 X 400 V ~	3x 5,5	3x 7,5	3x 11	9	8
3NKV 15/8 T	3 X 400 V ~	3x 7,5	3x 10	3x 14,8	10	9
3NKV 15/9 T	3 X 400 V ~	3x 7,5	3x 10	3x 14,8	12	10
3NKV 15/10 T	3 X 400 V ~	3x 11	3x 15	3x 22,4	13	11

MODEL	A	B	C	D	E	F	G	H	H1	Ø		WEIGHT kg
										DNA	DNM	
3 NKV 15	1265	1220	1200	1000	110	790	155	1525	236	DN 125	DN 100	141

3 NKV 20 - RESIDENTIAL/INDUSTRIAL PRESSURE BOOSTER SETS

Pumped liquid temperature range: from -15 °C to +80 °C - Maximum ambient temperature: 40 °C - Max flow rate: 87 m³/h

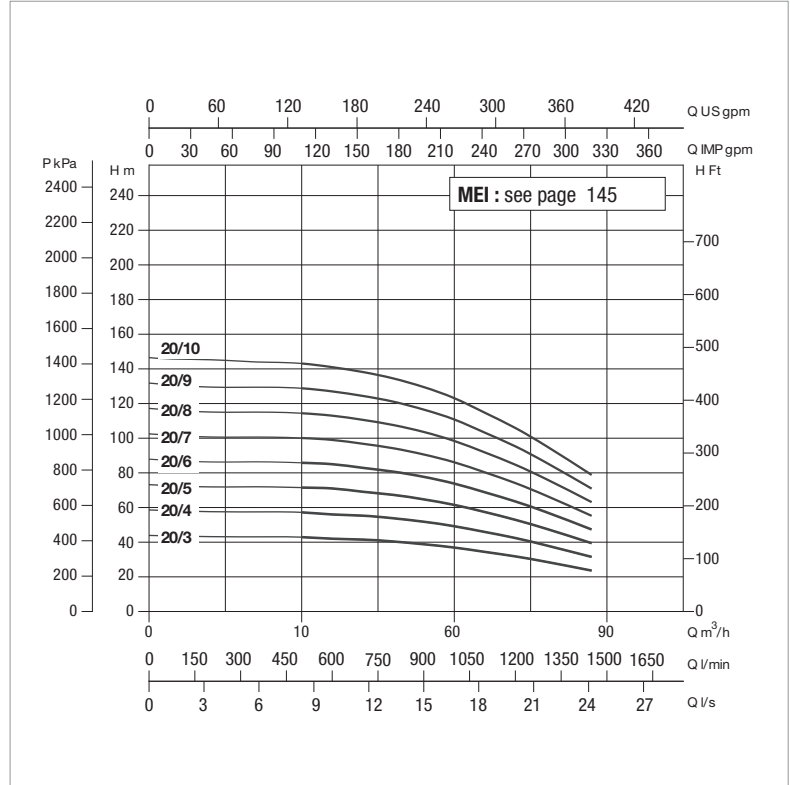
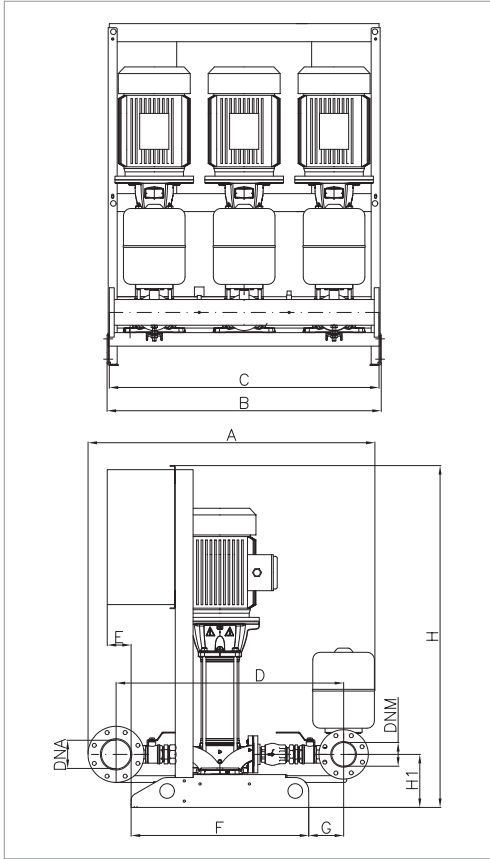

The performance curves are based on kinematic viscosity values = 1 mm²/s and density equal to 1000 kg/m³.
Curve tolerance according to ISO 9906.

Overall performance taking into account THREE pumps working at the same time.

MODEL	50 Hz POWER INPUT	P2 NOMINAL		In A	MAX OBTAINABLE PRESSURE BAR	STANDARD PRESSURE BAR
		KW	HP			
3NKV 20/3 T	3 X 400 V ~	3x4	3x5,5	3x7,6	4	3
3NKV 20/4 T	3 X 400 V ~	3x5,5	3x7,5	3x11	5,5	4,5
3NKV 20/5 T	3 X 400 V ~	3x5,5	3x7,5	3x11	7	6
3NKV 20/6 T	3 X 400 V ~	3x7,5	3x10	3x14,8	8,5	7
3NKV 20/7 T	3 X 400 V ~	3x7,5	3x10	3x14,8	10	8,5
3NKV 20/8 T	3 X 400 V ~	3x11	3x15	3x22,4	11	9,5
3NKV 20/9 T	3 X 400 V ~	3x11	3x15	3x22,4	12,5	10
3NKV 20/10 T	3 X 400 V ~	3x11	3x15	3x22,4	14	12

MODEL	A	B	C	D	E	F	G	H	H1	Ø		WEIGHT kg
										DNA	DNM	
3 NKV 15	1265	1220	1200	1000	110	790	155	1525	236	DN 125	DN 100	141

3 NKV 32 - RESIDENTIAL/INDUSTRIAL PRESSURE BOOSTER SETS

Pumped liquid temperature range: from -15 °C to +80 °C - Maximum ambient temperature: 40 °C - Max flow rate: 135 m³/h

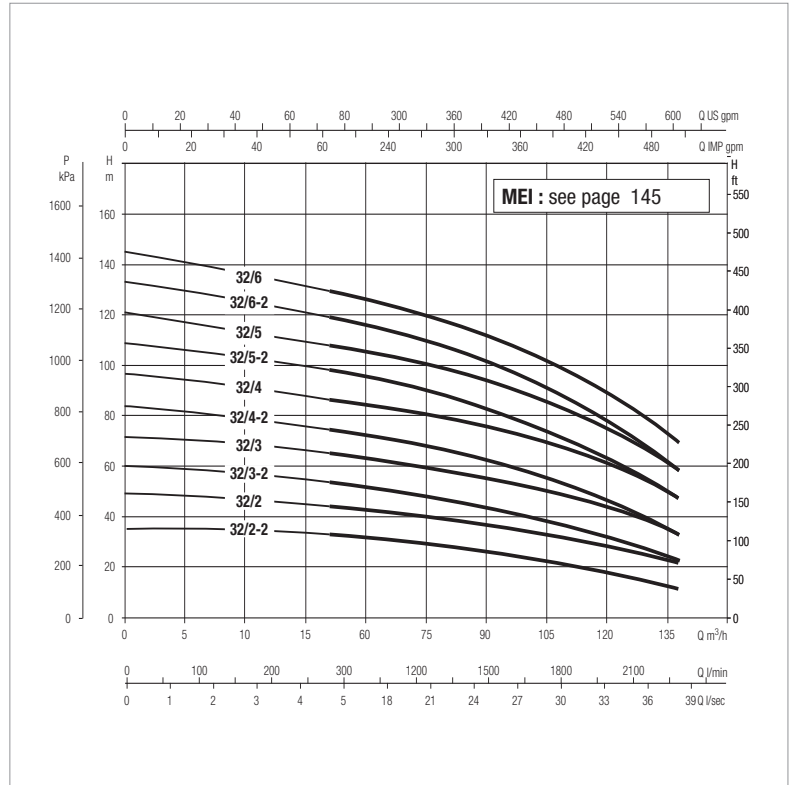
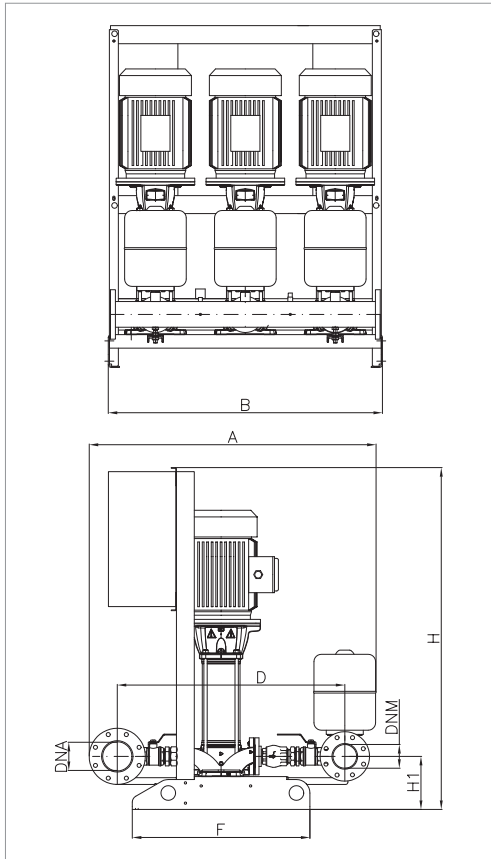

The performance curves are based on kinematic viscosity values = 1 mm²/s and density equal to 1000 kg/m³.
Curve tolerance according to ISO 9906.

Overall performance taking into account THREE pumps working at the same time.

MODEL	50 Hz POWER INPUT	P2 NOMINAL		In A	MAX FLOW RATE m ³ /h	MAX OBTAINABLE PRESSURE BAR	STANDARD PRESSURE BAR
		kW	HP				
3NKV 32/2-2 T 400-50	3x400 50-60Hz	3x4	3x5,5	3x8,1	135	3,6	2,5
3NKV 32/2 T 400-50	3x400 50-60Hz	3x5,5	3x7,5	3x10,4	135	4,8	3,5
3NKV 32/3-2 T 400-50	3x400 50-60Hz	3x5,5	3x7,5	3x10,4	135	6	5
3NKV 32/3 T IE3 400-50	3x400 50-60Hz	3x7,5	3x10	3x13,4	135	7,3	6
3NKV 32/4-2 T IE3 400-50	3x400 50-60Hz	3x7,5	3x10	3x13,4	135	8,4	7
3NKV 32/4 T IE3 400-50	3x400 50-60Hz	3x11	3x15	3x19,4	135	9,8	8,5
3NKV 32/5-2 T IE3 400-50	3x400 50-60Hz	3x11	3x15	3x19,4	135	10,9	9
3NKV 32/5 T IE3 400-50	3x400 50-60Hz	3x15	3x20	3x26,5	135	12	11
3NKV 32/6-2 T IE3 400-50	3x400 50-60Hz	3x15	3x20	3x26,5	135	13,4	12
3NKV 32/6 T IE3 400-50	3x400 50-60Hz	3x15	3x20	3x26,5	135	14,6	13

MODEL	A	B	D	F	H	H1	Ø		PACKING DIMENSIONS
							DNA	DNM	
3NKV 32/2-2 T 400-50	1613	1500	1331	890	1043	271	150	125	1500x2250x2200
3NKV 32/2 T 400-50	1613	1500	1331	890	1280	271	150	125	1500x2250x2200
3NKV 32/3-2 T 400-50	1613	1500	1331	890	1362	271	150	125	1500x2250x2200
3NKV 32/3 T IE3 400-50	1613	1500	1331	890	1362	271	150	125	1500x2250x2200
3NKV 32/4-2 T IE3 400-50	1613	1500	1331	890	1444	271	150	125	1500x2250x2200
3NKV 32/4 T IE3 400-50	1613	1500	1331	890	1579	271	150	125	1500x2250x2200
3NKV 32/5-2 T IE3 400-50	1613	1500	1331	890	1661	271	150	125	1500x2250x2200
3NKV 32/5 T IE3 400-50	1613	1500	1331	890	1661	271	150	125	1500x2250x2200
3NKV 32/6-2 T IE3 400-50	1613	1500	1331	890	1743	271	150	125	1500x2250x2200
3NKV 32/6 T IE3 400-50	1613	1500	1331	890	1743	271	150	125	1500x2250x2200

For the weights contact our sales network.

3 NKV 45 - RESIDENTIAL/INDUSTRIAL PRESSURE BOOSTER SETS

Pumped liquid temperature range: from -15 °C to +80 °C - Maximum ambient temperature: 40 °C - Max flow rate: 210 m³/h

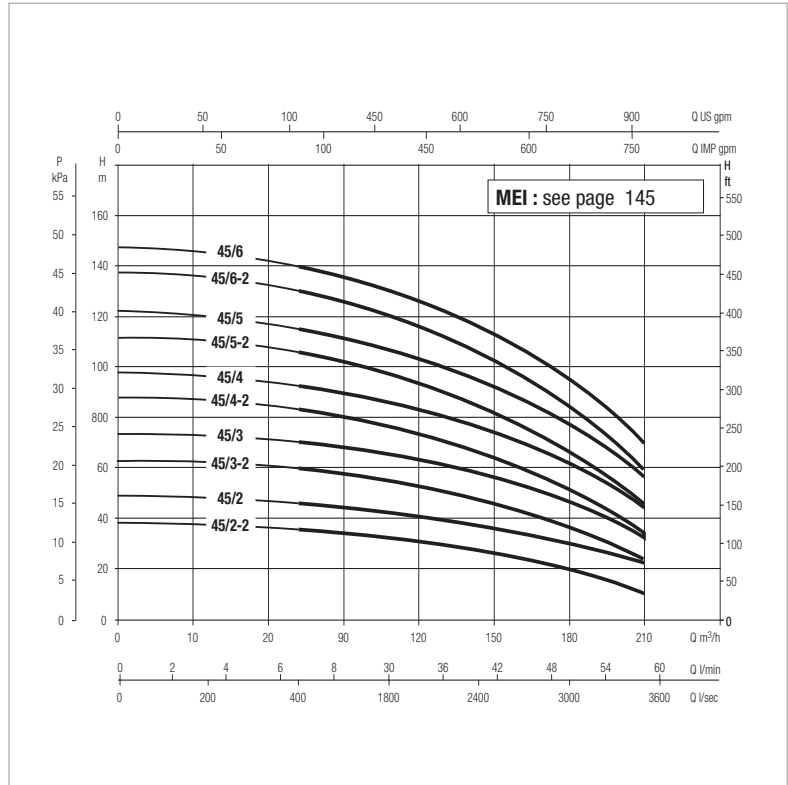
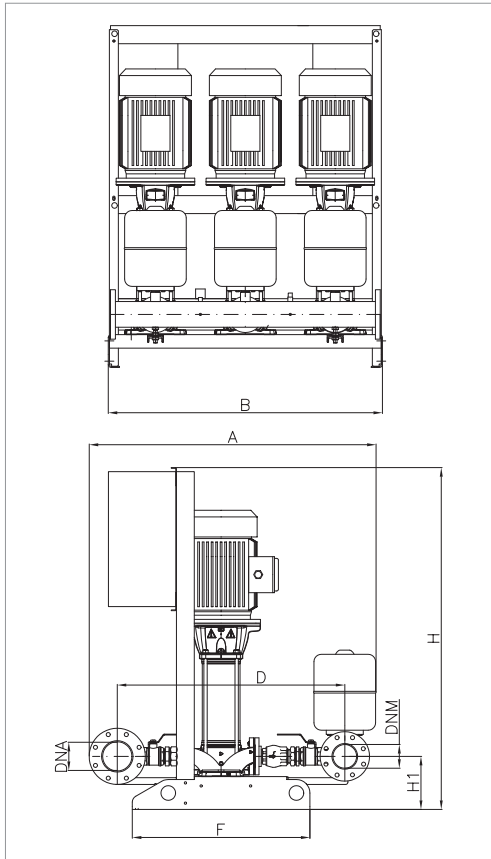

The performance curves are based on kinematic viscosity values = 1 mm²/s and density equal to 1000 kg/m³.
Curve tolerance according to ISO 9906.

Overall performance taking into account THREE pumps working at the same time.

MODEL	50 Hz POWER INPUT	P2 NOMINAL		In A	MAX FLOW RATE m ³ /h	MAX OBTAINABLE PRESSURE BAR	STANDARD PRESSURE BAR
		kW	HP				
3NKV 45/2-2 T 400-50	3x400 50-60Hz	3x5,5	3x7,5	3x10,4	210	3,8	2,5
3NKV 45/2 T IE3 400-50	3x400 50-60Hz	3x7,5	3x10	3x13,4	210	4,8	3,5
3NKV 45/3-2 T IE3 400-50	3x400 50-60Hz	3x11	3x15	3x19,4	210	6,3	5
3NKV 45/3 T IE3 400-50	3x400 50-60Hz	3x11	3x15	3x19,4	210	7,3	6
3NKV 45/4-2 T IE3 400-50	3x400 50-60Hz	3x15	3x20	3x26,5	210	8,7	7
3NKV 45/4 T IE3 400-50	3x400 50-60Hz	3x15	3x20	3x26,5	210	9,7	8
3NKV 45/5-2 T IE3 400-50	3x400 50-60Hz	3x18,5	3x25	3x32	210	11,2	10
3NKV 45/5 T IE3 400-50	3x400 50-60Hz	3x18,5	3x25	3x32	210	12,2	11
3NKV 45/6-2 T IE3 400-50	3x400 50-60Hz	3x22	3x30	3x38	210	13,7	12
3NKV 45/6 T IE3 400-50	3x400 50-60Hz	3x22	3x30	3x38	210	14,7	13

MODEL	A	B	D	F	H	H1	Ø		PACKING DIMENSIONS
							DNA	DNM	
3NKV 45/2-2 T 400-50	1710	1500	1345	890	1315	306	200	150	1500x2250x2200
3NKV 45/2 T IE3 400-50	1710	1500	1345	890	1315	306	200	150	1500x2250x2200
3NKV 45/3-2 T IE3 400-50	1710	1500	1345	890	1532	306	200	150	1500x2250x2200
3NKV 45/3 T IE3 400-50	1710	1500	1345	890	1532	306	200	150	1500x2250x2200
3NKV 45/4-2 T IE3 400-50	1710	1500	1345	890	1614	306	200	150	1500x2250x2200
3NKV 45/4 T IE3 400-50	1710	1500	1345	890	1614	306	200	150	1500x2250x2200
3NKV 45/5-2 T IE3 400-50	1710	1500	1345	890	1751	306	200	150	1500x2250x2200
3NKV 45/5 T IE3 400-50	1710	1500	1345	890	1751	306	200	150	1500x2250x2200
3NKV 45/6-2 T IE3 400-50	1710	1500	1345	890	1853	306	200	150	1500x2250x2200
3NKV 45/6 T IE3 400-50	1710	1500	1345	890	1853	306	200	150	1500x2250x2200

For the weights contact our sales network.



4 NKV 10 - RESIDENTIAL/INDUSTRIAL PRESSURE BOOSTER SETS

Pumped liquid temperature range: from -15 °C to +80 °C - Maximum ambient temperature: 40 °C - Max flow rate: 52 m³/h

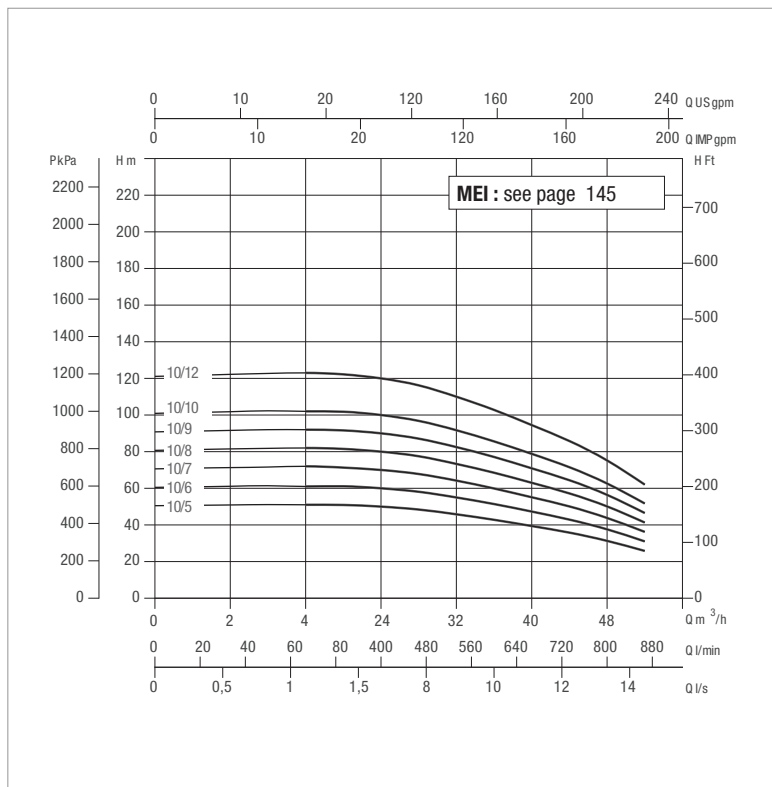
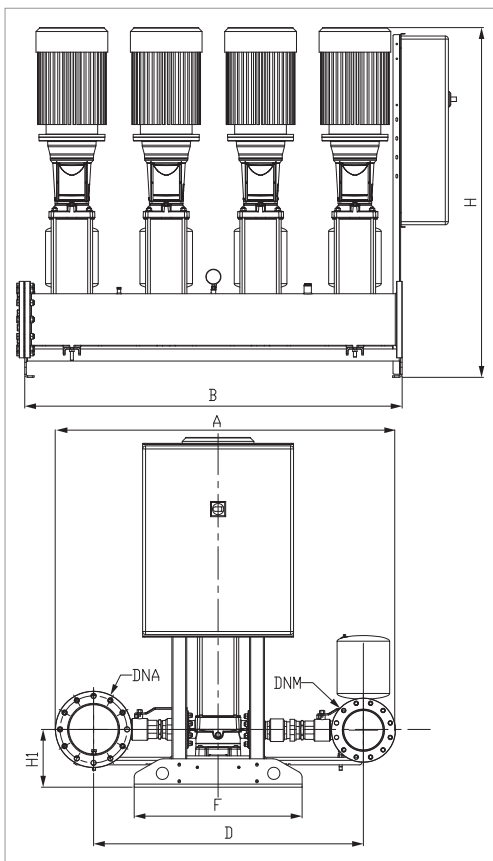

The performance curves are based on kinematic viscosity values = 1 mm²/s and density equal to 1000 kg/m³.
Curve tolerance according to ISO 9906.

Overall performance taking into account FOUR pumps working at the same time.

MODEL	50 Hz POWER INPUT	P2 NOMINAL		In A	MAX FLOW RATE m ³ /h	MAX OBTAINABLE PRESSURE BAR	STANDARD PRESSURE BAR
		kW	HP				
4NKV 10/5 T 400-50	3x400 50-60Hz	4x2,2	4x3	4x4,7	52	5	4
4NKV 10/6 T 400-50	3x400 50-60Hz	4x2,2	4x3	4x4,7	52	6	5
4NKV 10/7 T 400-50	3x400 50-60Hz	4x3	4x4	4x5,8	52	7	6
4NKV 10/8 T 400-50	3x400 50-60Hz	4x3	4x4	4x5,8	52	8	7
4NKV 10/9 T 400-50	3x400 50-60Hz	4x3	4x4	4x5,8	52	9	8
4NKV 10/10 T 400-50	3x400 50-60Hz	4x4	4x5,5	4x7,6	52	10	9
4NKV 10/12 T 400-50	3x400 50-60Hz	4x4	4x5,5	4x7,6	52	12	11

MODEL	A	B	D	F	H	H1	Ø		PACKING DIMENSIONS
							DNA	DNM	
4NKV 10/5 T 400-50	1151	1936	901	890	1505	226	100	80	1500x22500x2200
4NKV 10/6 T 400-50	1151	1936	901	890	1505	226	100	80	1500x22500x2200
4NKV 10/7 T 400-50	1151	1936	901	890	1505	226	100	80	1500x22500x2200
4NKV 10/8 T 400-50	1151	1936	901	890	1505	226	100	80	1500x22500x2200
4NKV 10/9 T 400-50	1151	1936	901	890	1505	226	100	80	1500x22500x2200
4NKV 10/10 T 400-50	1151	1936	901	890	1505	226	100	80	1500x22500x2200
4NKV 10/12 T 400-50	1151	1936	901	890	1505	226	100	80	1500x22500x2200

4 NKV 15 - RESIDENTIAL/INDUSTRIAL PRESSURE BOOSTER SETS

Pumped liquid temperature range: from -15 °C to +80 °C - Maximum ambient temperature: 40 °C - Max flow rate: 96 m³/h

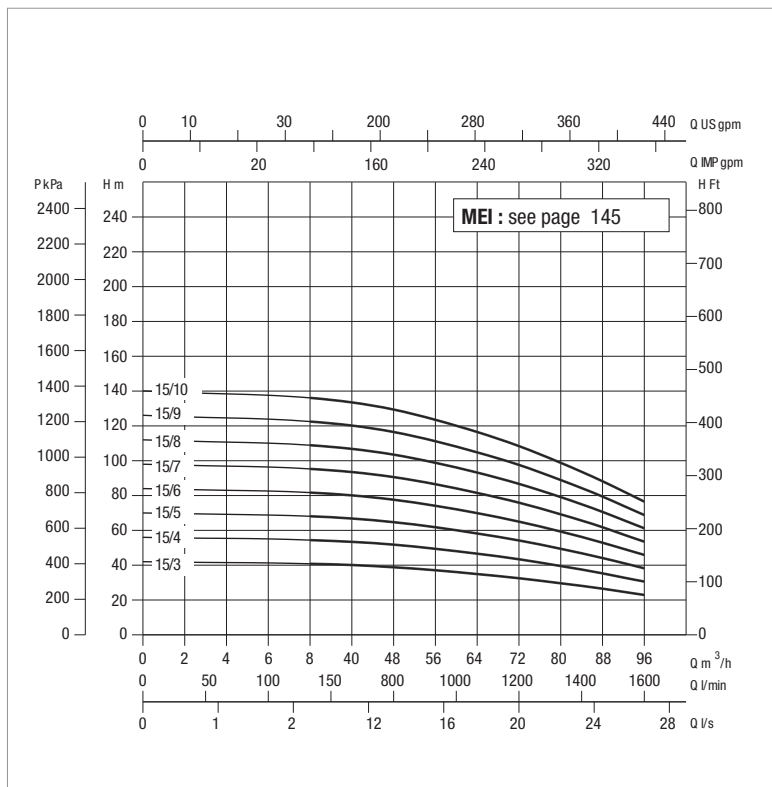
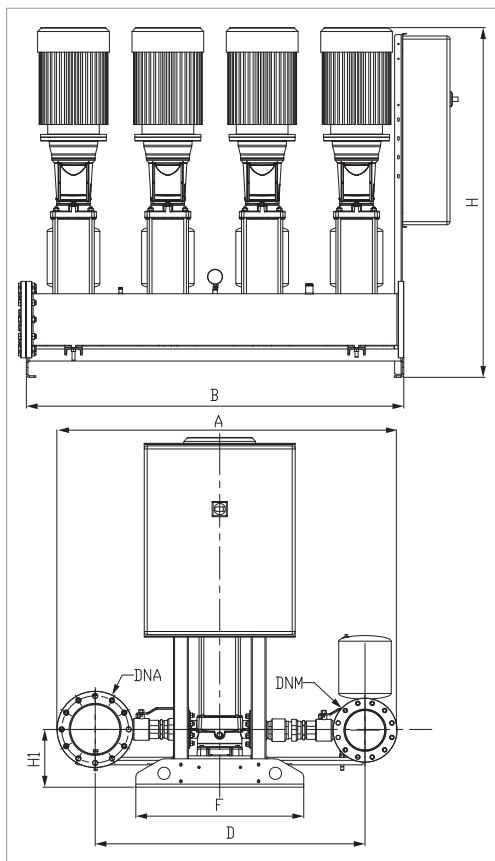

The performance curves are based on kinematic viscosity values = 1 mm²/s and density equal to 1000 kg/m³.
Curve tolerance according to ISO 9906.

Overall performance taking into account FOUR pumps working at the same time.

MODEL	50 Hz POWER INPUT	P2 NOMINAL		In A	MAX FLOW RATE m ³ /h	MAX OBTAINABLE PRESSURE BAR	STANDARD PRESSURE BAR
		kW	HP				
4NKV 15/3 T 400-50	3x400 50-60Hz	4x3	4x4	4x5,8	96	4	3
4NKV 15/4 T 400-50	3x400 50-60Hz	4x4	4x5,5	4x7,6	96	5,4	4,5
4NKV 15/5 T 400-50	3x400 50-60Hz	4x4	4x5,5	4x7,6	96	6,8	5,5
4NKV 15/6 T 400-50	3x400 50-60Hz	4x5,5	4x7,5	4x11	96	8,1	7
4NKV 15/7 T 400-50	3x400 50-60Hz	4x5,5	4x7,5	4x11	96	9,5	8,5
4NKV 15/8 T 400-50	3x400 50-60Hz	4x7,5	4x10	4x14,8	96	10,8	9
4NKV 15/9 T 400-50	3x400 50-60Hz	4x7,5	4x10	4x14,8	96	12,2	11
4NKV 15/10 T 400-50	3x400 50-60Hz	4x11	4x15	4x22,4	96	13,6	12

MODEL	A	B	D	F	H	H1	Ø		PACKING DIMENSIONS
							DNA	DNM	
4NKV 15/3 T 400-50	1246	1936	996	890	1505	226	150	125	1500x22500x2200
4NKV 15/4 T 400-50	1246	1936	996	890	1505	226	150	125	1500x22500x2200
4NKV 15/5 T 400-50	1246	1936	996	890	1505	226	150	125	1500x22500x2200
4NKV 15/6 T 400-50	1246	1936	996	890	1505	226	150	125	1500x22500x2200
4NKV 15/7 T 400-50	1246	1936	996	890	1505	226	150	125	1500x22500x2200
4NKV 15/8 T 400-50	1246	1936	996	890	1505	226	150	125	1500x22500x2200
4NKV 15/9 T 400-50	1246	1936	996	890	1505	226	150	125	1500x22500x2200
4NKV 15/10 T 400-50	1246	1936	996	890	1505	226	150	125	1500x22500x2200

4 NKV 20 - RESIDENTIAL/INDUSTRIAL PRESSURE BOOSTER SETS

Pumped liquid temperature range: from -15 °C to +80 °C - Maximum ambient temperature: 40 °C - Max flow rate: 116 m³/h

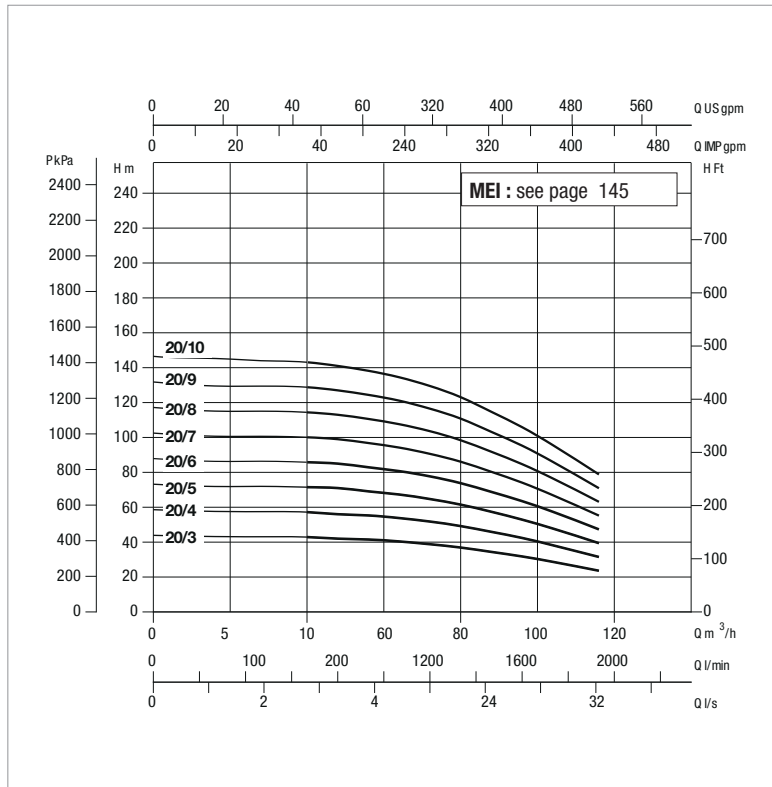
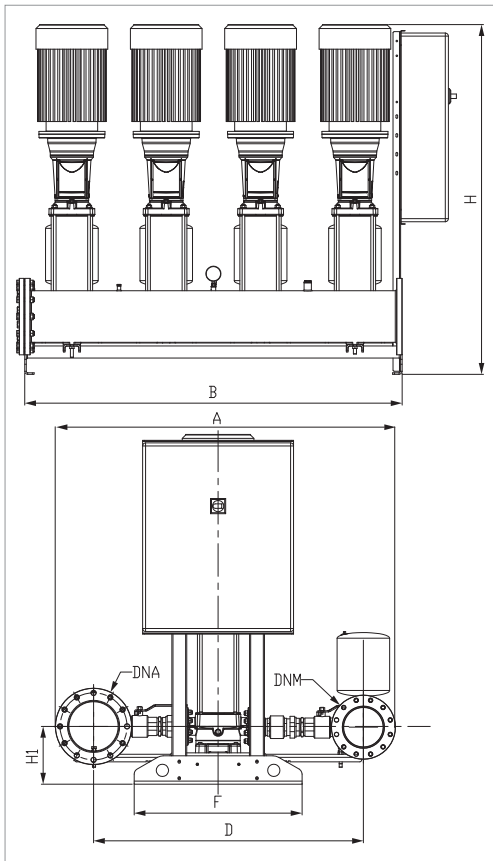

The performance curves are based on kinematic viscosity values = 1 mm²/s and density equal to 1000 kg/m³.
Curve tolerance according to ISO 9906.

Overall performance taking into account FOUR pumps working at the same time.

MODEL	50 Hz POWER INPUT	P2 NOMINAL		In A	MAX FLOW RATE m ³ /h	MAX OBTAINABLE PRESSURE BAR	STANDARD PRESSURE BAR
		kW	HP				
4NKV 20/3 T 400-50	3x400 50-60Hz	4x4	4x5,5	4x7,6	116	4,3	3,5
4NKV 20/4 T 400-50	3x400 50-60Hz	4x5,5	4x7,5	4x11	116	5,8	4,5
4NKV 20/5 T 400-50	3x400 50-60Hz	4x5,5	4x7,5	4x11	116	7,3	6
4NKV 20/6 T 400-50	3x400 50-60Hz	4x7,5	4x10	4x14,8	116	8,7	7
4NKV 20/7 T 400-50	3x400 50-60Hz	4x7,5	4x10	4x14,8	116	10,2	9
4NKV 20/8 T 400-50	3x400 50-60Hz	4x11	4x15	4x22,4	116	11,7	10
4NKV 20/9 T 400-50	3x400 50-60Hz	4x11	4x15	4x22,4	116	13,1	12
4NKV 20/10 T 400-50	3x400 50-60Hz	4x11	4x15	4x22,4	116	14,6	13

MODEL	A	B	D	F	H	H1	Ø		PACKING DIMENSIONS
							DNA	DNM	
4NKV 20/3 T 400-50	1246	1936	996	890	1505	226	150	125	1500x22500x2200
4NKV 20/4 T 400-50	1246	1936	996	890	1505	226	150	125	1500x22500x2200
4NKV 20/5 T 400-50	1246	1936	996	890	1505	226	150	125	1500x22500x2200
4NKV 20/6 T 400-50	1246	1936	996	890	1505	226	150	125	1500x22500x2200
4NKV 20/7 T 400-50	1246	1936	996	890	1505	226	150	125	1500x22500x2200
4NKV 20/8 T 400-50	1246	1936	996	890	1505	226	150	125	1500x22500x2200
4NKV 20/9 T 400-50	1246	1936	996	890	1505	226	150	125	1500x22500x2200
4NKV 20/10 T 400-50	1246	1936	996	890	1505	226	150	125	1500x22500x2200

4 NKV 32 - RESIDENTIAL/INDUSTRIAL PRESSURE BOOSTER SETS

Pumped liquid temperature range: from -15 °C to +80 °C - Maximum ambient temperature: 40 °C - Max flow rate: 180 m³/h

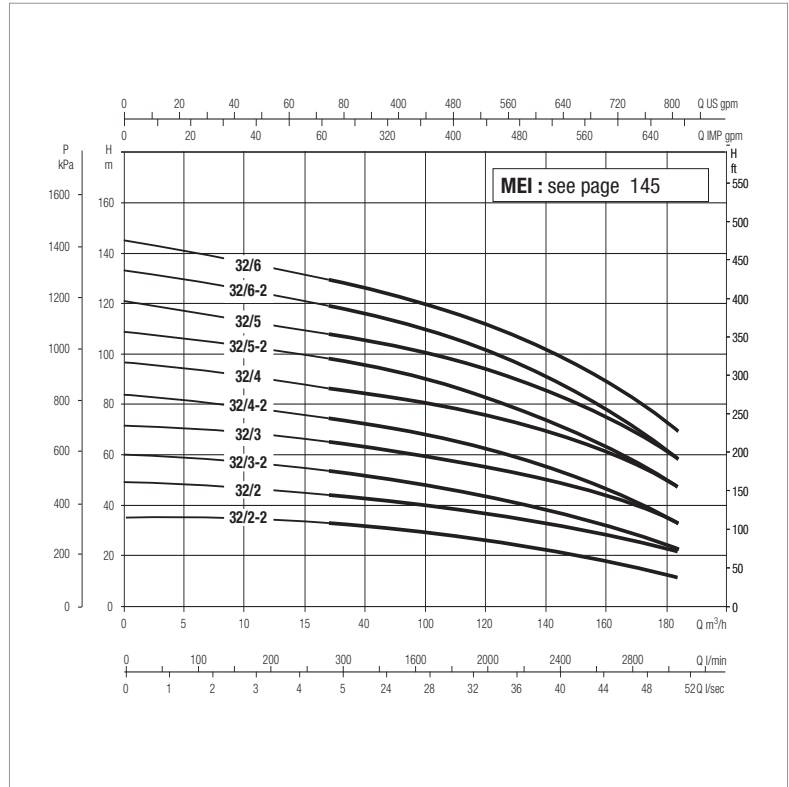
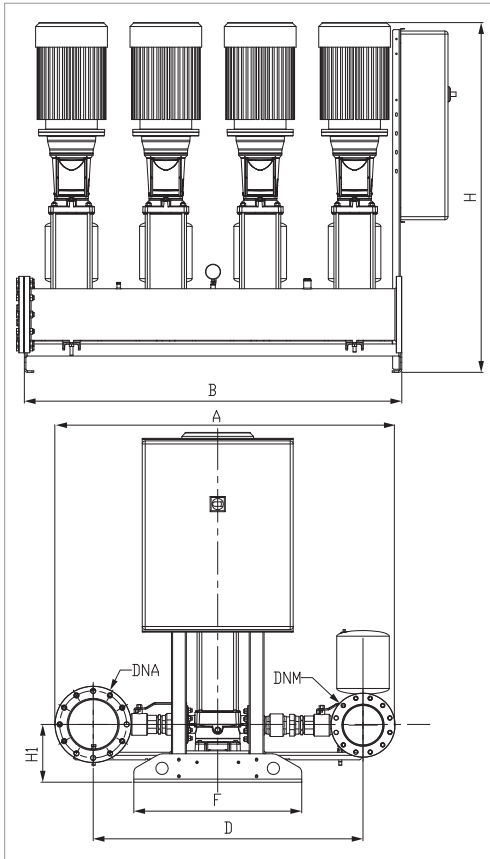

The performance curves are based on kinematic viscosity values = 1 mm²/s and density equal to 1000 kg/m³.
Curve tolerance according to ISO 9906.

Overall performance taking into account FOUR pumps working at the same time.

MODEL	50 Hz POWER INPUT	P2 NOMINAL		In A	MAX FLOW RATE m ³ /h	MAX OBTAINABLE PRESSURE BAR	STANDARD PRESSURE BAR
		kW	HP				
4NKV 32/3-2 T 400-50	3x400 50-60Hz	4x4	4x5,5	4x8,1	180	3,6	2,5
4NKV 32/2 T 400-50	3x400 50-60Hz	4x5,5	4x7,5	4x10,4	180	4,8	3,5
4NKV 32/3-2 T 400-50	3x400 50-60Hz	4x5,5	4x7,5	4x10,4	180	6	5
4NKV 32/3 T IE3 400-50	3x400 50-60Hz	4x7,5	4x10	4x13,4	180	7,3	6
4NKV 32/4-2 T IE3 400-50	3x400 50-60Hz	4x7,5	4x10	4x13,4	180	8,4	7
4NKV 32/4 T IE3 400-50	3x400 50-60Hz	4x11	4x15	4x19,4	180	9,8	8,5
4NKV 32/5-2 T IE3 400-50	3x400 50-60Hz	4x11	4x15	4x19,4	180	10,9	9
4NKV 32/5 T IE3 400-50	3x400 50-60Hz	4x15	4x20	4x26,5	180	12	11
4NKV 32/6-2 T IE3 400-50	3x400 50-60Hz	4x15	4x20	4x26,5	180	13,4	12
4NKV 32/6 T IE3 400-50	3x400 50-60Hz	4x15	4x20	4x26,5	180	14,6	13

MODEL	A	B	D	F	H	H1	Ø		PACKING DIMENSIONS
							DNA	DNM	
4NKV 32/3-2 T 400-50	1670	2000	1345	890	1043	271	200	100	2660x1760x2200
4NKV 32/2 T 400-50	1670	2000	1345	890	1280	271	200	100	2660x1760x2200
4NKV 32/3-2 T 400-50	1670	2000	1345	890	1362	271	200	100	2660x1760x2200
4NKV 32/3 T IE3 400-50	1670	2000	1345	890	1362	271	200	100	2660x1760x2200
4NKV 32/4-2 T IE3 400-50	1670	2000	1345	890	1444	271	200	100	2660x1760x2200
4NKV 32/4 T IE3 400-50	1670	2000	1345	890	1579	271	200	100	2660x1760x2200
4NKV 32/5-2 T IE3 400-50	1670	2000	1345	890	1661	271	200	100	2660x1760x2200
4NKV 32/5 T IE3 400-50	1670	2000	1345	890	1661	271	200	100	2660x1760x2200
4NKV 32/6-2 T IE3 400-50	1670	2000	1345	890	1743	271	200	100	2660x1760x2200
4NKV 32/6 T IE3 400-50	1670	2000	1345	890	1743	271	200	100	2660x1760x2200

4 NKV 45 - RESIDENTIAL/INDUSTRIAL PRESSURE BOOSTER SETS

Pumped liquid temperature range: from -15 °C to +80 °C - Maximum ambient temperature: 40 °C - Max flow rate: 280 m³/h

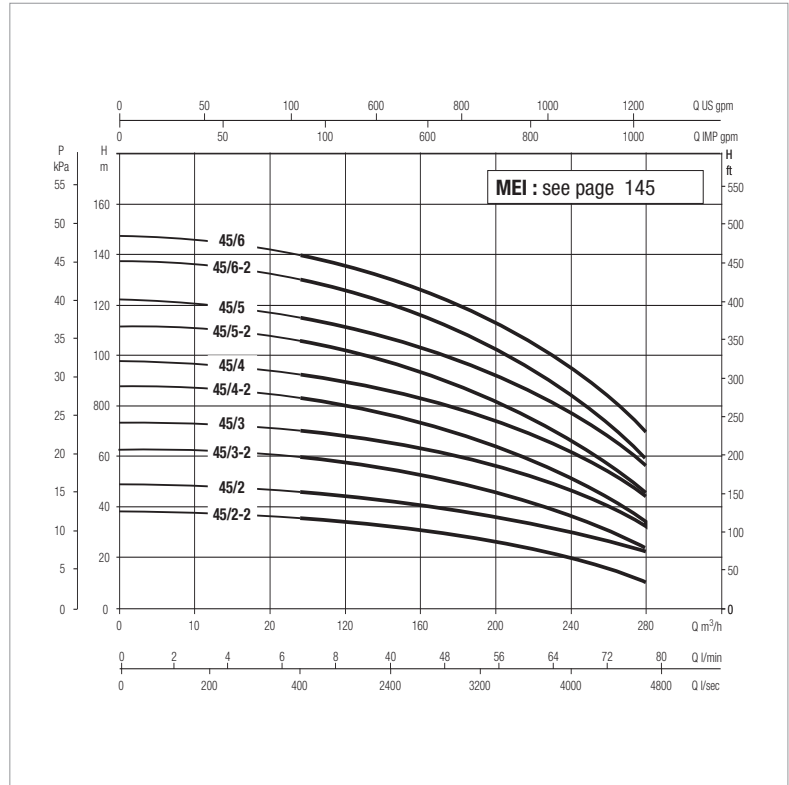
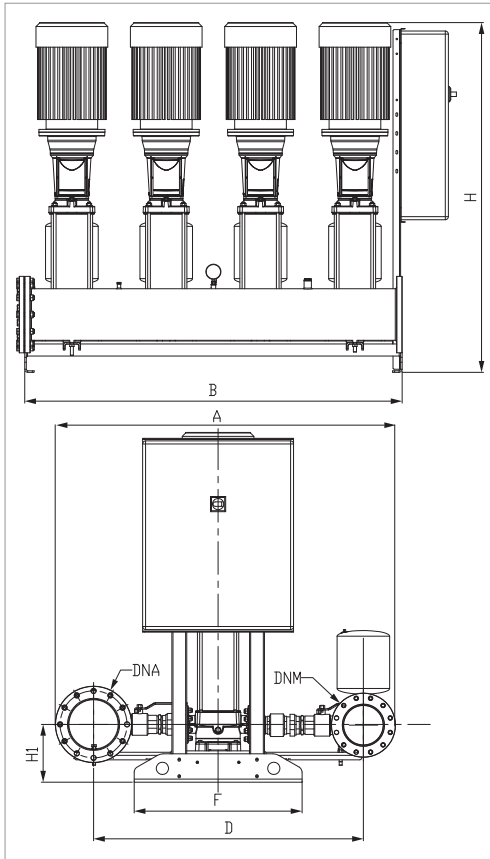

The performance curves are based on kinematic viscosity values = 1 mm²/s and density equal to 1000 kg/m³.
Curve tolerance according to ISO 9906.

Overall performance taking into account FOUR pumps working at the same time.

MODEL	50 Hz POWER INPUT	P2 NOMINAL		In A	MAX FLOW RATE m ³ /h	MAX OBTAINABLE PRESSURE BAR	STANDARD PRESSURE BAR
		kW	HP				
4NKV 45/2-2 T 400-50	3x400 50-60Hz	4x5,5	4x7,5	4x10,4	280	3,8	2,5
4NKV 45/2 T 400-50	3x400 50-60Hz	4x7,5	4x10	4x13,4	280	4,8	3,5
4NKV 45/3-2 T 400-50	3x400 50-60Hz	4x11	4x15	4x19,4	280	6,3	5
4NKV 45/3 T 400-50	3x400 50-60Hz	4x11	4x15	4x19,4	280	7,3	6
4NKV 45/4-2 T 400-50	3x400 50-60Hz	4x15	4x20	4x26,5	280	8,7	7
4NKV 45/4 T 400-50	3x400 50-60Hz	4x15	4x20	4x26,5	280	9,7	8
4NKV 45/5-2 T 400-50	3x400 50-60Hz	4x18,5	4x25	4x32	280	11,2	10
4NKV 45/5 T 400-50	3x400 50-60Hz	4x18,5	4x25	4x32	280	12,2	11
4NKV 45/6-2 T 400-50	3x400 50-60Hz	4x22	4x30	4x38	280	13,7	12
4NKV 45/6 T 400-50	3x400 50-60Hz	4x22	4x30	4x38	280	14,7	13

MODEL	A	B	D	F	H	H1	Ø		PACKING DIMENSIONS
							DNA	DNM	
4NKV 45/2-2 T 400-50	1800	2000	1430	890	1315	306	250	200	2660x1760x2200
4NKV 45/2 T 400-50	1800	2000	1430	890	1315	306	250	200	2660x1760x2200
4NKV 45/3-2 T 400-50	1800	2000	1430	890	1532	306	250	200	2660x1760x2200
4NKV 45/3 T 400-50	1800	2000	1430	890	1532	306	250	200	2660x1760x2200
4NKV 45/4-2 T 400-50	1800	2000	1430	890	1614	306	250	200	2660x1760x2200
4NKV 45/4 T 400-50	1800	2000	1430	890	1614	306	250	200	2660x1760x2200
4NKV 45/5-2 T 400-50	1800	2000	1430	890	1751	306	250	200	2660x1760x2200
4NKV 45/5 T 400-50	1800	2000	1430	890	1751	306	250	200	2660x1760x2200
4NKV 45/6-2 T 400-50	1800	2000	1430	890	1853	306	250	200	2660x1760x2200
4NKV 45/6 T 400-50	1800	2000	1430	890	1853	306	250	200	2660x1760x2200

2 NKV 10/15/20 WITH E-BOX

PRESSURE BOOSTER SETS WITH TWO VERTICAL AXIS MULTISTAGE CENTRIFUGAL PUMPS

E.BOX
PAGE 175



TECHNICAL DATA

Line voltage: 400V three phase.

Voltage of electric pump: 400V three phase.

Power frequency: 50-60 Hz.

Installation: vertical only.

Operating range: from 4 to 58 m³/h.

Pumped liquid temperature range: from 0 °C to + 80 °C.

Maximum ambient temperature: 40°C.

Max pressure: 14bar.

Pumped liquid: clean, free of solids.

Pressure control range: from 3 to 14 bar.

Protection class: IP55

IE2 motors as standard from 0,75 kW to 5,5 kW - IE3 ≥ 7,5 kW

APPLICATIONS

NKV E-BOX sets have been designed and produced to meet the needs of the modern engineering solutions of civil or industrial systems. Their characteristic features are versatility of use and extremely quiet operation.

CONSTRUCTION FEATURES

HYDRAULIC SECTION

2 NKV 15 - NKV 20 vertical multistage electric pumps.

AISI 304 stainless steel impellers, AISI 304 stainless steel base liner, Si/Si cartridge seal, stiff joint motor-pump coupling.

External ventilation cooled normalised three phase asynchronous electric motor.

Galvanised steel base supporting the pumps, the hydraulic section, and the electric control panel.

Suction and delivery manifolds in AISI 304 STAINLESS STEEL, complete with blind flange.

Isolator valves on the suction and delivery of each pump.

Check valves on the delivery of each pump.

No. 1 18 litre membrane expansion vessel for each pump.

ELECTRICAL SECTION

Supplied in an IP 55 protection class self-extinguishing thermoplastic material box, the control panel protects the electric pumps from abnormal conditions such as: overload and overtemperature (with automatic reset), short circuit (with fuses - Plus model only), pump current surges (amperometric protection), abnormal voltage, dry run, quick starts, pressure sensor fault, or inconsistency of the external protection commands.

Front panel components:

- General disconnecter with padlockable door lock.
- AUT-0-MAN operation selection pushbuttons.
- Alarm RESET pushbutton.
- Display for all models.
- Operation, stop, alarm notification lamps.

Control panel components:

- Electronic control card with protection fuses and contactors.
- Power input connection terminals.
- Dry run or overpressure pressure switch connection terminals (optional).
- Alarm notification clean contacts (voltage free).
- Function selection mini dip switch (pressure transmitter or pressure switches, standard or additional tanks).

The sets are supplied in a sturdy cardboard packaging on wooden pallet and instruction leaflet with electric diagram.

2 NKV 10 - RESIDENTIAL/INDUSTRIAL PRESSURE BOOSTER SETS

Pumped liquid temperature range: from -15 °C to +70 °C - Maximum ambient temperature: +40 °C - Max flow rate: 26 m³/h

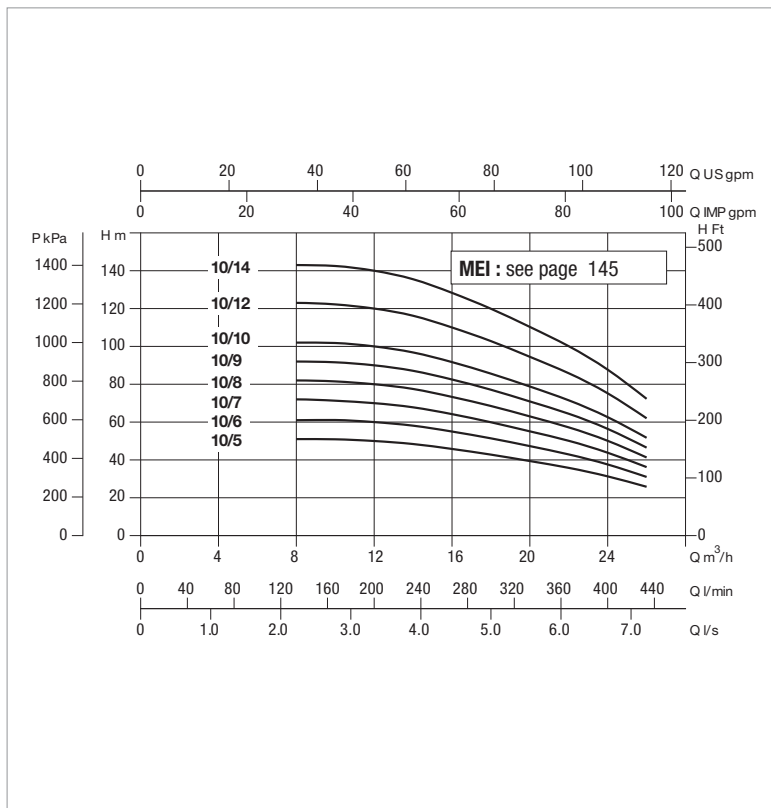
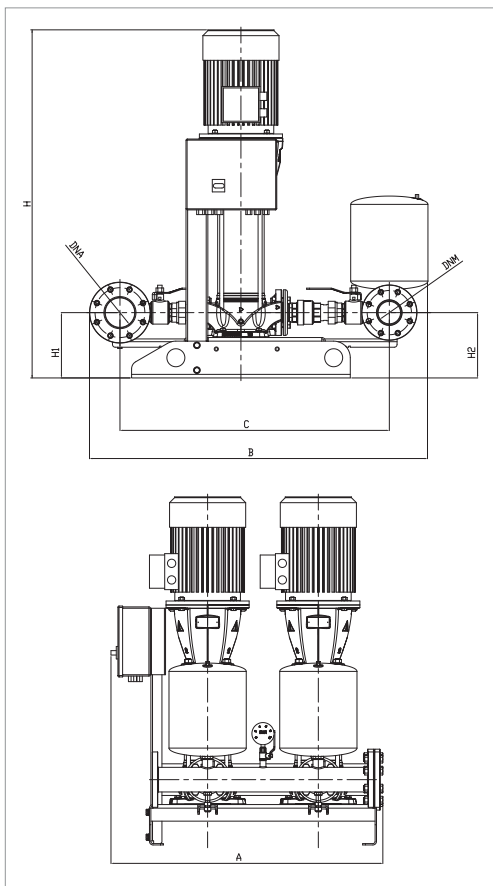

The performance curves are based on kinematic viscosity values = 1 mm²/s and density equal to 1000 kg/m³. Curve tolerance according to ISO 9906.

Overall performance taking into account TWO pumps working at the same time.

MODEL	POWER INPUT	P2 NOMINAL		In A	CONTROL PANEL MODEL	MAXIMUM FLOW RATE m ³ /h	MAX OBTAINABLE PRESSURE BAR	STANDARD PRESSURE BAR
		kW	hp					
2 NKV 10/5 T E-BOX 400/50	3 x 400 50 Hz	2x2,2	2x3	2x4,7	E-BOX 2G T 12A 400/50-60	26	5,5	4,5
2 NKV 10/6 T E-BOX 400/50	3 x 400 50 Hz	2x2,2	2x3	2x4,7	E-BOX 2G T 12A 400/50-60	26	6	5
2 NKV 10/7 T E-BOX 400/50	3 x 400 50 Hz	2x3	2x4	2x5,8	E-BOX 2G T 12A 400/50-60	26	7	6
2 NKV 10/8 T E-BOX 400/50	3 x 400 50 Hz	2x3	2x4	2x5,8	E-BOX 2G T 12A 400/50-60	26	8	7
2 NKV 10/9 T E-BOX 400/50	3 x 400 50 Hz	2x3	2x4	2x5,8	E-BOX 2G T 12A 400/50-60	26	9	8
2 NKV 10/10 T E-BOX 400/50	3 x 400 50 Hz	2x4	2x5,5	2x7,6	E-BOX 2G T 12A 400/50-60	26	10	9
2 NKV 10/12 T E-BOX 400/50	3 x 400 50 Hz	2x4	2x5,5	2x7,6	E-BOX 2G T 12A 400/50-60	26	12	11
2 NKV 10/14 T E-BOX 400/50	3 x 400 50 Hz	2x5,5	2x7,5	2x11	E-BOX 2G T 12A 400/50-60	26	14	13

MODEL	A	B	C	H	H1	H2	DNa	DNM	WEIGHT	PACKING (wxhxd)
2 NKV 10/5 T E-BOX 400/50	853	1060	875	960	236	236	2" 1/2	2" 1/2	238	1000x1400x2200
2 NKV 10/6 T E-BOX 400/50	853	1060	875	993	236	236	2" 1/2	2" 1/2	239	1000x1400x2200
2 NKV 10/7 T E-BOX 400/50	853	1060	875	1073	236	236	2" 1/2	2" 1/2	259	1000x1400x2200
2 NKV 10/8 T E-BOX 400/50	853	1060	875	1106	236	236	2" 1/2	2" 1/2	261	1000x1400x2200
2 NKV 10/9 T E-BOX 400/50	853	1060	875	1139	236	236	2" 1/2	2" 1/2	263	1000x1400x2200
2 NKV 10/10 T E-BOX 400/50	853	1060	875	1187	236	236	2" 1/2	2" 1/2	282	1000x1400x2200
2 NKV 10/12 T E-BOX 400/50	853	1060	875	1253	236	236	2" 1/2	2" 1/2	286	1000x1400x2200
2 NKV 10/14 T E-BOX 400/50	853	1060	875	1449	236	236	2" 1/2	2" 1/2	342	1000x1400x2200

2 NKV 15 - RESIDENTIAL/INDUSTRIAL PRESSURE BOOSTER SETS

Pumped liquid temperature range: from -15 °C to +70 °C - Maximum ambient temperature: +40 °C - Max flow rate: 48 m³/h

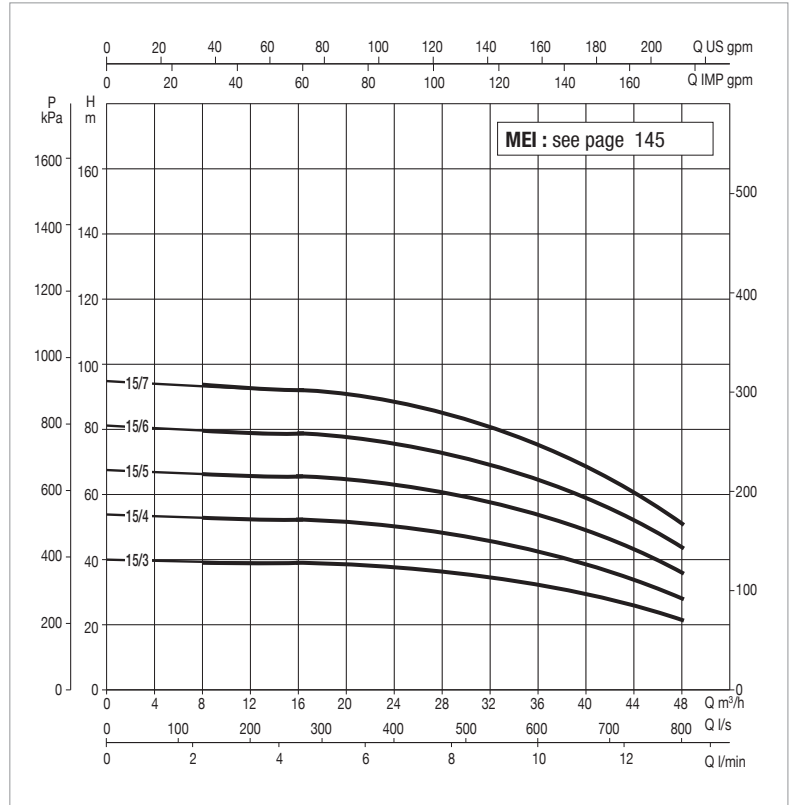
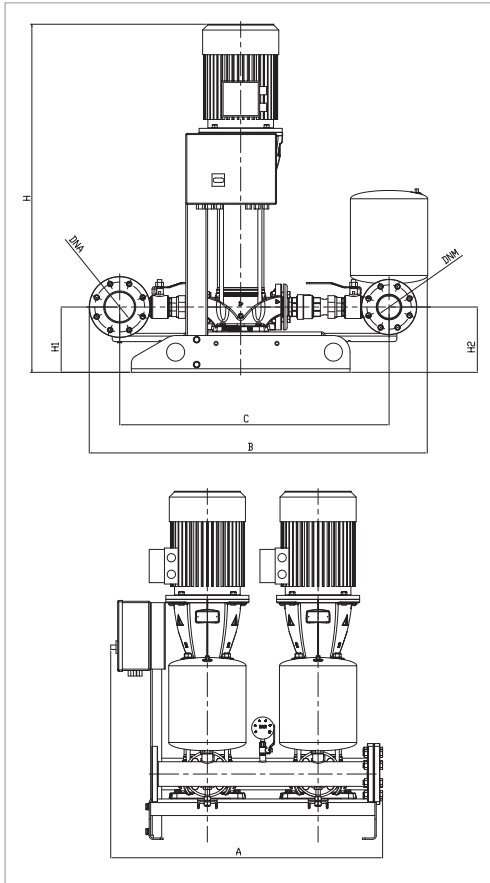

The performance curves are based on kinematic viscosity values = 1 mm²/s and density equal to 1000 kg/m³. Curve tolerance according to ISO 9906.

Overall performance taking into account TWO pumps working at the same time.

MODEL	POWER INPUT	P2 NOMINAL		In A	CONTROL PANEL MODEL	MAXIMUM FLOW RATE m ³ /h	MAX OBTAINABLE PRESSURE BAR	STANDARD PRESSURE BAR
		kW	hp					
2 NKV 15/3 T E-BOX 400/50	3 x 400 50 Hz	2x3	2x4	5,8	E-BOX 2G T 12A 400/50-60	48	4	3,5
2 NKV 15/4 T E-BOX 400/50	3 x 400 50 Hz	2x4	2x5.5	7,6	E-BOX 2G T 12A 400/50-60	48	5	4
2 NKV 15/5 T E-BOX 400/50	3 x 400 50 Hz	2x4	2x5.5	7,6	E-BOX 2G T 12A 400/50-60	48	6,5	5
2 NKV 15/6 T E-BOX 400/50	3 x 400 50 Hz	2x5.5	2x7.5	11	E-BOX 2G T 12A 400/50-60	48	7,5	6,5
2 NKV 15/7 T E-BOX 400/50	3 x 400 50 Hz	2x5.5	2x7.5	11	E-BOX 2G T 12A 400/50-60	48	9	8

MODEL	A	B	C	H	H1	H2	DNA	DNM	WEIGHT	PACKING (wxhxd)
2 NKV 15/3 T E-BOX 400/50	982	1221	973	964	236	236	100	80	276	1000x1400x2150
2 NKV 15/4 T E-BOX 400/50	982	1221	973	1099	236	236	100	80	280	1000x1400x2150
2 NKV 15/5 T E-BOX 400/50	982	1221	973	1148	236	236	100	80	285	1000x1400x2150
2 NKV 15/6 T E-BOX 400/50	982	1221	973	1257	236	236	100	80	374	1000x1400x2150
2 NKV 15/7 T E-BOX 400/50	982	1221	973	1307	236	236	100	80	377	1000x1400x2150

2 NKV 20 - RESIDENTIAL/INDUSTRIAL PRESSURE BOOSTER SETS

Pumped liquid temperature range: from -15 °C to +70 °C - Maximum ambient temperature: +40 °C - Max flow rate: 58 m³/h

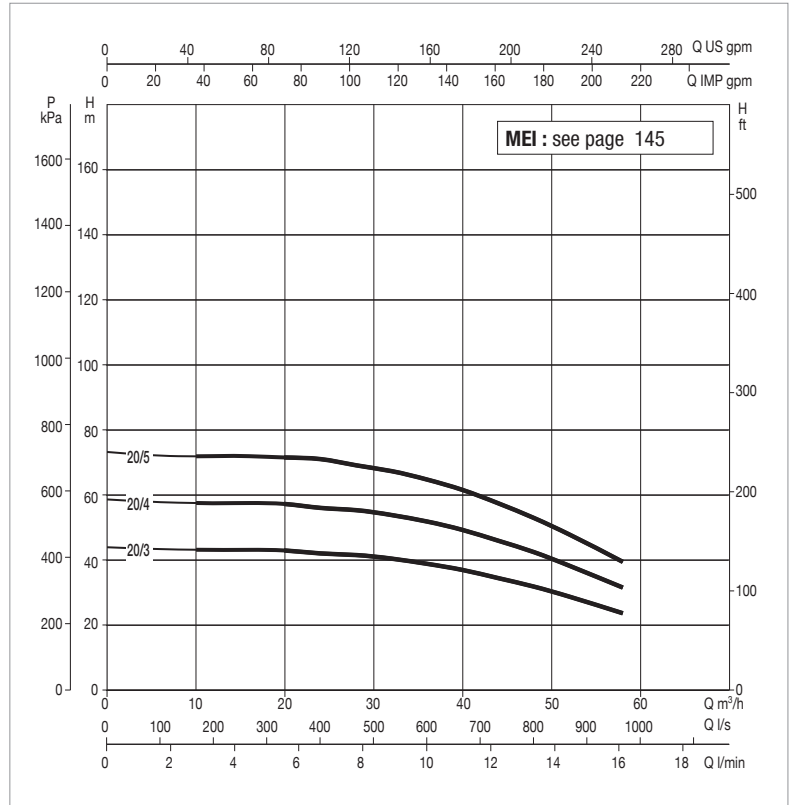
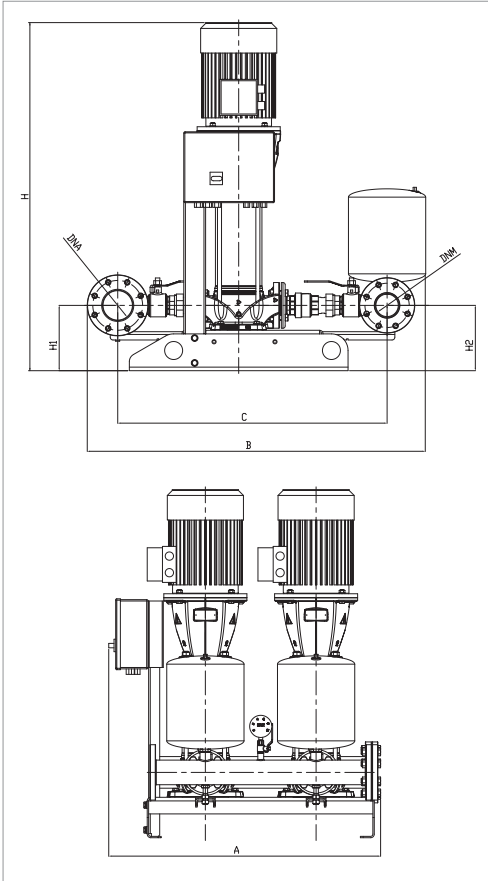

The performance curves are based on kinematic viscosity values = 1 mm²/s and density equal to 1000 kg/m³. Curve tolerance according to ISO 9906.

Overall performance taking into account TWO pumps working at the same time.

MODEL	POWER INPUT	P2 NOMINAL		In A	CONTROL PANEL MODEL	MAXIMUM FLOW RATE m ³ /h	MAX OBTAINABLE PRESSURE BAR	STANDARD PRESSURE BAR
		kW	hp					
2 NKV 20/3 T E-BOX 400/50	3 x 400 50 Hz	2x4	2x5.5	7,6	E-BOX 2G T 12A 400/50-60	58	4	3,5
2 NKV 20/4 T E-BOX 400/50	3 x 400 50 Hz	2x5.5	2x7.5	11	E-BOX 2G T 12A 400/50-60	58	6	5
2 NKV 20/5 T E-BOX 400/50	3 x 400 50 Hz	2x5.5	2x7.5	11	E-BOX 2G T 12A 400/50-60	58	7	6

MODEL	A	B	C	H	H1	H2	DNA	DNM	WEIGHT	PACKING (wxhxd)
2 NKV 20/3 T E-BOX 400/50	982	1221	973	1049	236	236	100	80	284	1000x1400x2150
2 NKV 20/4 T E-BOX 400/50	982	1221	973	1158	236	236	100	80	364	1000x1400x2150
2 NKV 20/5 T E-BOX 400/50	982	1221	973	1208	236	236	100	80	366	1000x1400x2150

1/2/3 NKP-G / 1/2/3 K

PRESSURE BOOSTER SETS WITH 1 - 2 - 3 NKP-G / K SERIES CENTRIFUGAL PUMPS

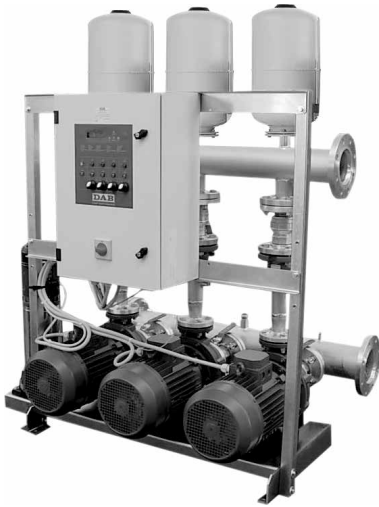

TECHNICAL DATA

Line voltage: 400V three phase.

Voltage of electric pump: 400V three phase.

Power frequency: 50-60 Hz.

Installation: vertical only.

Operating range: from 4 to 720 m³/h.

Pumped liquid temperature range: from -15 °C to + 70 °C (max 40 °C for the version with jockey pump).

Maximum ambient temperature: 40°C.

Max pressure: 10bar.

Pumped liquid: clean, free of solids.

Protection class: IP55

IE2 motors as standard from 0,75 kW to 5,5 kW - IE3 ≥ 7,5 kW.

APPLICATIONS

Industrial sets have been designed and produced to meet the needs of the modern engineering solutions of civil or industrial systems. The use of standardised centrifugal electric pumps and/or double impeller centrifugal pumps guarantees a high power/performance ratio.

The applications of industrial groups cover the most varied sectors:

Industry, Hotels, Water pipelines, Irrigation, Residential buildings, Spas.

The fundamental concept that has driven our Engineers in developing these pumps sets, was to offer a simple to use, flexible, and extremely reliable product.

ADVANTAGES OF USE

High performance, Multi-functionality, Silent operation, Compact size, Less maintenance.

OPERATING MODES

In idle conditions, (zero water request), the system is under static pressure. Following the request of water from an user, the system pressure decreases. The pressure drop is detected by an electronic pressure transmitter on the delivery manifold of the set, connected to the pump control unit on the front of the electric control panel. The control unit reads the pressure signal and manages the start and stop of all the pumps, following preset parameters that can be changed by the user (average pressure, pump start delay, dangerous pressure level, etc.). The electric pumps activate in cascade, so that the maximum flow rate requested by the system can be split on several pumps. (e.g. one pump in operation at -> 20 m³/h; two pumps in operation at -> 40 m³/h).

The jockey electric pump intervenes for small system pressure drops, therefore avoiding pointless starts of the main pumps. The pump starting order is switched at each operating cycle.

INDUSTRIAL SET COMPOSITION

Electric pumps used

MAIN PUMPS

K 70-80 / 300-400 series double impeller centrifugal electric pumps.

Cast iron pump body, technopolymer impellers, AISI 304 pump shaft, carbon/ceramic mechanical seal.

DIN-EN 733 compliant, series 32 - 40 - 50 NKP integral shaft monobloc centrifugal electric pumps.

Cast iron pump body and impeller, AISI 304 pump shaft, carbon/silicon carbide mechanical seal - EPDM.

DIN-EN 733 compliant, series 65 - 80 NKP-G monobloc centrifugal electric pump with coupling.

Cast iron pump body and impeller, AISI 304 pump shaft, carbon/silicon carbide mechanical seal - EPDM.

JOCKEY ELECTRIC PUMP

Vertical axis multistage centrifugal electric pump.

Technopolymer pump body and impellers, AISI 303 pump shaft, carbon/ceramic mechanical seal.

MECHANICAL STRUCTURE

Galvanised steel base supporting all the main pumps, complete with floor anchoring holes.

Jockey pump galvanised steel base, fastened to the base of the main pumps. Control panel support frame fastened on the pump base.

1/2/3 NKP-G / 1/2/3 K

PRESSURE BOOSTER SETS WITH 1 - 2 - 3 NKP-G / K SERIES CENTRIFUGAL PUMPS

HYDRAULIC STRUCTURE

Galvanised steel suction and delivery manifolds, sized for the total flow rate of the set, complete with blind flange (anti-vibration coupling available as optional).

No. 1 isolator valve **on the suction of each main pump.**

No. 1 diverter adaptor, no. 1 check valve, no. 1 isolator valve **on the delivery of each main pump.**

No. 1 20 litre 16 bar membrane expansion vessel for each main electric pump.

No. 1 4-20 mA pressure transmitter and manometer on the delivery manifold of the set.

No. 1 jockey electric pump connected to the suction* and delivery manifolds and complete with suction and delivery isolator valves and delivery check valve.

* 1 main pump sets are supplied without suction manifold.

CONTROL PANEL FUNCTIONS

IP 55 metal box electric control panel, installed on the pump base, CONTAINING:

General door lock switch.

400/24 V auxiliary transformers.

Main and jockey electric pump motor protectors.

Direct starters for pumps up to 7,5 kW.

Star-triangle starters for pumps exceeding 7,5 kWatt.

Power input and external signal connection terminal box.

Front panel: AUT-0-MAN operation selectors, voltage lamps, pump operation, pump block, dry run, under and over pressure alarm, KL 1 control unit. The pump control unit, with data set-up pushbuttons and display, manages the operating logic of the set. The set leaves the factory set to a standard pressure value (SET POINT). The control unit manages the start and the stop of the main pumps based on pressure differentials (adjustable) and a delay time (adjustable).

The jockey electric pumps keep the system at a pressure slightly higher than the pressure of the main pumps.

From the control unit it is possible to select one of the following modes of operation:

- 1) **Standard** - 1-2-3 pumps, with or without jockey pump (all pumps start in cascade).
- 2) **Rescue** - Pump no. 1 and pump no. 2 start in cascade, the third pump activates when either pump 1 or pump 2 are faulty.
- 3) **4 pumps** - without jockey pump (all pumps start in cascade).

The control panel stops the pumps in the following cases:

Pump overcurrent.

Dry run - low suction pressure (after a settable time and subject to the installation of a minimum pressure switch).

Pump overpressure (adjustable pressure).

FUNCTIONS DISPLAYED ON THE CONTROL UNIT

The double line display gives the possibility of displaying the following parameters:

SET POINT pressure set.

Instantaneous system pressure.

No. of pumps active.

No. of pump operation hours.

Alarms.

As OPTIONAL on request, the following parameters can also be displayed:

Instantaneous electric power kW.

Total electric energy kWh.

Instantaneous flow rate l/min.

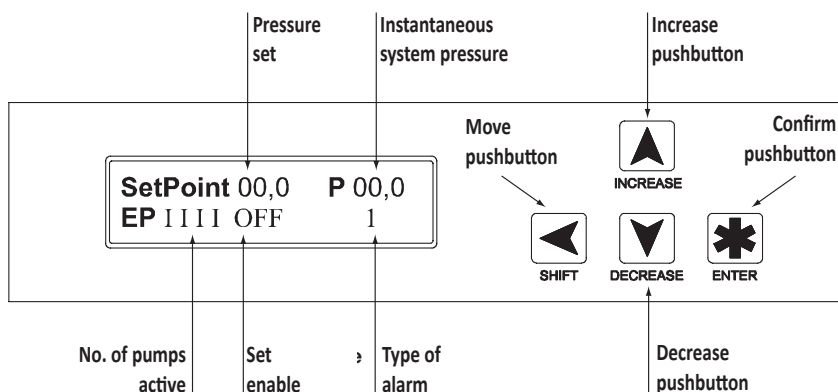

ALARM LEGEND	
1	MOTOR MAINTENANCE
2	PARAMETER ERROR
4	PRESSURE TRANSMITTER
8	MOTOR THERMAL PROTECTIONS
H2O?	MIN. PRESSURE (3 SELF-RESETS)
64	MINIMUM PRESSURE (MANUAL RESET)

1/2/3 NKP-G / 1/2/3 K

PRESSURE BOOSTER SETS WITH 1 - 2 - 3 NKP-G / K SERIES CENTRIFUGAL PUMPS

PUMP SEIZING PREVENTION

The control panel includes the PUMP SEIZING PREVENTION function as standard, which can be activated on the KL 1 control unit.

The seizing prevention function starts the main pumps on a regular basis (adjustable time), to prevent them, or the system components, from seizing due to long periods of inactivity.

The main pumps are started in sequence for a few seconds.

At the end of the tests, any faults are notified by an alarm on the display, and the alarm N.O. contact is activated.

CONTROL PANEL EXTERNAL CONNECTIONS

The control panel terminal board offers the following voltage-free N.O. alarm contacts:

sensor fault, overpressure, dry run, pump current surge, 24 V auxiliary circuit fault.

PRESSURE CALIBRATION

EXAMPLE OF CALIBRATION OF THE SET-POINT PRESSURE ON THE PUMP CONTROL UNIT

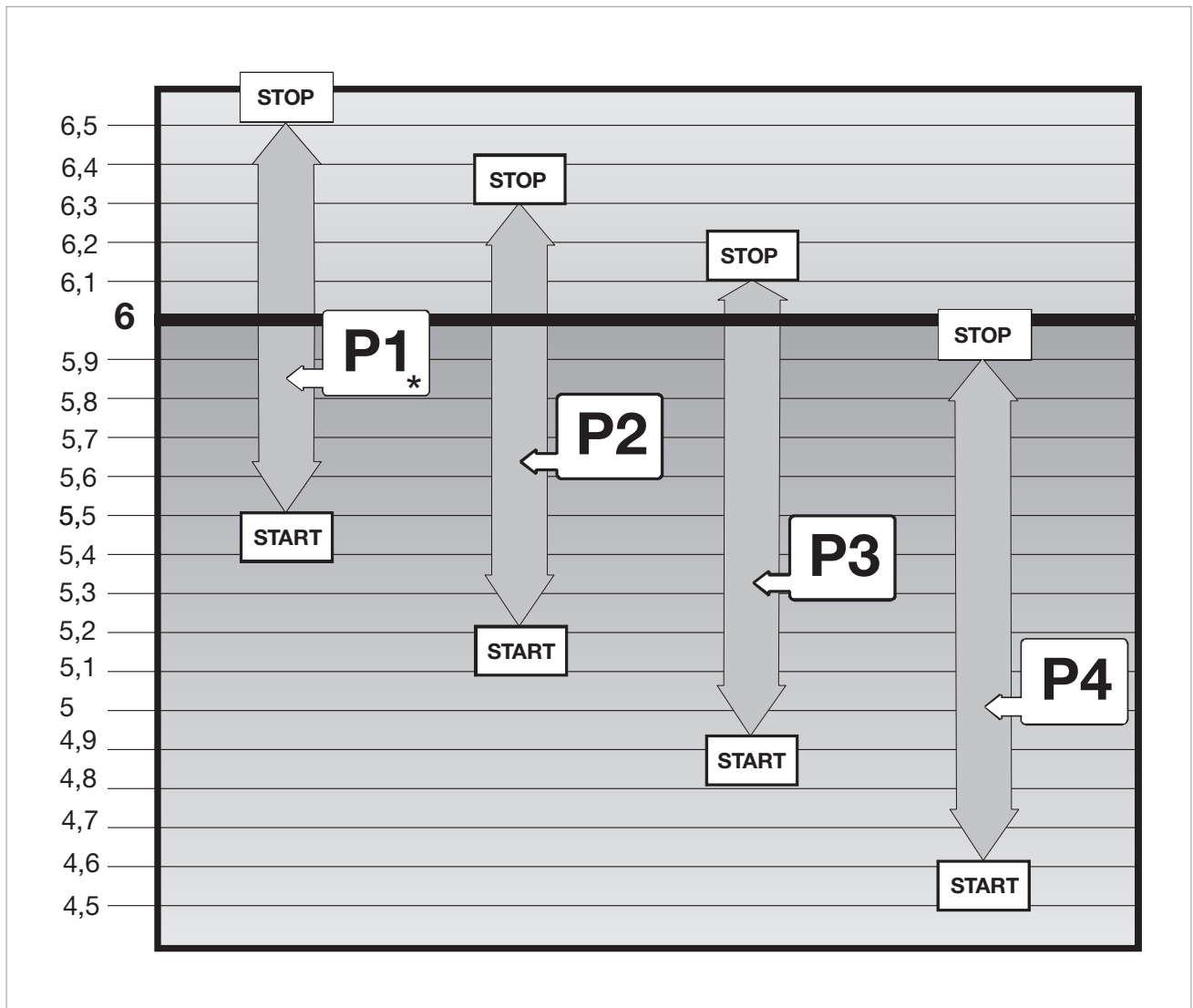

* Electric pump P1 or Jockey pump

Set-point Pressure Set to **6 bar (example)**

Jockey pump P1 Start/Stop differential:	set to 1 bar (standard DAB value)
Pumps P2, P3 and P4 Start Differential:	set to 0,3 bar (standard DAB value)
Pumps P2, P3 and P4 Stop Differential:	set to 0,2 bar (standard DAB value)

1 K - RESIDENTIAL/INDUSTRIAL PRESSURE BOOSTER SETS

Pumped liquid temperature range: from -15 °C to +70 °C - Jockey pump pumped liquid temperature range: from +0 °C to +40 °C.
 Maximum ambient temperature: +40 °C

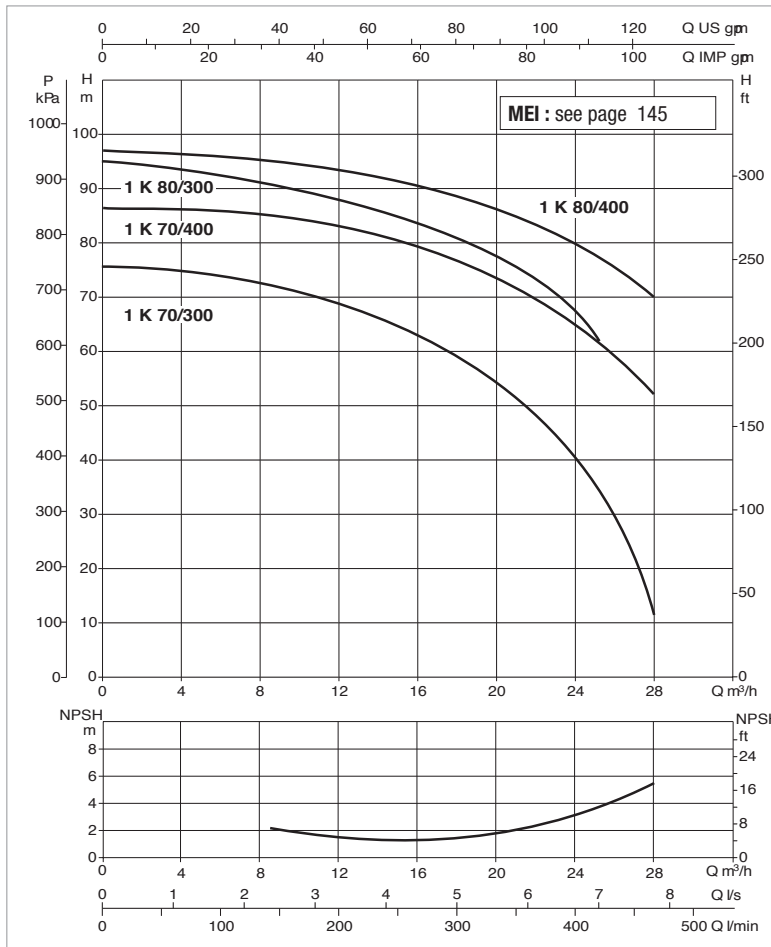
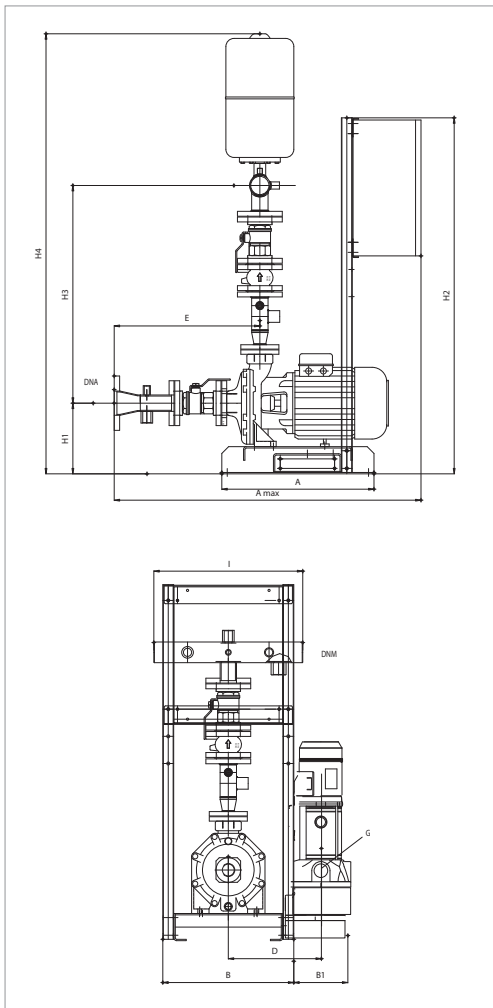

The performance curves are based on kinematic viscosity values = 1 mm²/s and density equivalent to 1000 kg/m³
 Curve tolerance according to ISO 9906.

MODEL	POWER INPUT 50 Hz	P2 NOMINAL		RATED P2 JOCKEY	In A	FLOW m ³ /h	MAX OBTAINABLE PRESSURE BAR	STANDARD PRESSURE BAR
		kW	HP	kW				
1K 70/300 + KVCX 65/50	3x400 V	5,5	7,5	1,1	12,9	6-22	7,3	6,5
1K 80/300 + KVCX 65/80	3x400 V	7,5	10	1,1	15	6-24	9,2	8,5
1K 70/400 + KVCX 65/80	3x400 V	9,2	12,5	2,2	18	9-30	8,3	7,5
1K 80/400 + KVCX 65/80	3x400 V	11	15	2,2	21	9-30	9,5	8,5

MODEL	A	A max	B	B1*	C	D*	E	G*	H1	H2	H3	H4	I	DNA	DNM
1K 70/300 + KVCX 65/50	560	1129	482	199	-	343	536	1" 1/4	260	1310	801	1619	548	DN80	1" 1/2
1K 80/300 + KVCX 65/80	560	1129	482	199	-	343	536	1" 1/4	260	1310	801	1619	548	DN80	2" 1/2
1K 70/400 + KVCX 65/80	560	1129	482	199	-	343	536	1" 1/4	260	1310	801	1619	548	DN80	2" 1/2
1K 80/400 + KVCX 65/80	560	1129	482	199	-	343	536	1" 1/4	260	1310	801	1619	548	DN80	2" 1/2

* The sizes are for the set with jockey pump. For the sizes of the set without jockey pump, disregard B1, D, and G.
 For the weights contact our sales network.

2K - RESIDENTIAL/INDUSTRIAL PRESSURE BOOSTER SETS

Pumped liquid temperature range: from -15 °C to +70 °C - Jockey pump pumped liquid temperature range: from +0 °C to +40 °C.
Maximum ambient temperature: +40 °C

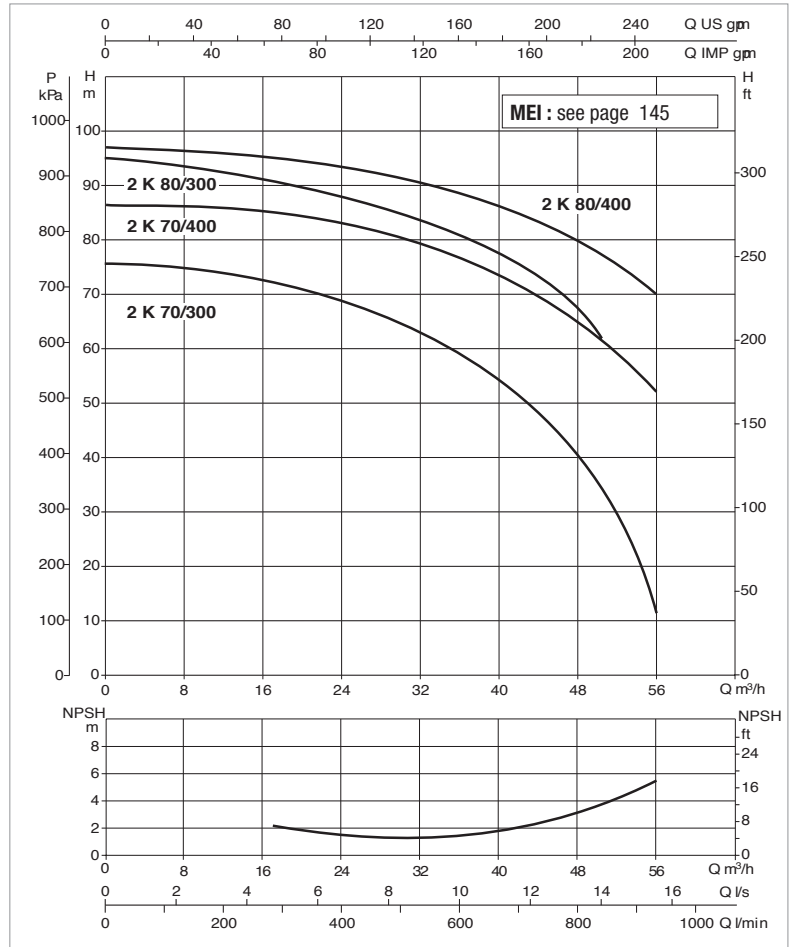
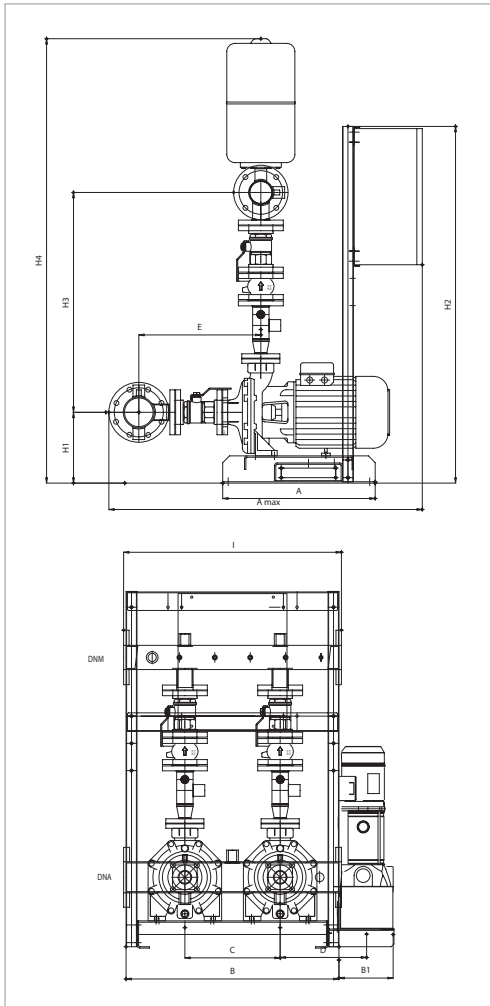

The performance curves are based on kinematic viscosity values = 1 mm²/s and density equivalent to 1000 kg/m³
Curve tolerance according to ISO 9906.
Overall performance taking into account TWO pumps working at the same time.

MODEL	POWER INPUT 50 Hz	P2 NOMINAL		RATED P2 JOCKEY	In A	FLOW m ³ /h	MAX OBTAINABLE PRESSURE BAR	STANDARD PRESSURE BAR
		kW	HP	kW				
2K 70/300 + KVCX 65/50	3x400V	2x5,5	2x7,5	1,1	2x12,9	6-44,7	,3	6,5
2K 80/300 + KVCX 65/80	3x400V	2x7,5	2x10	1,1	2x15	6-48	9,2	8,5
2K 70/400 + KVCX 65/80	3x400V	2x9,2	2x12,5	2,2	2x18	9-60	8,3	7,5
2K 80/400 + KVCX 65/80	3x400V	2x11	2x15	2,2	2x21	9-60	9,5	8,5

MODEL	A	A max	B	B1*	C	D*	E	H1	H2	H3	H4	I	DNA	DNM
2K 70/300 + KVCX 65/50	560	1151	782	199	350	318	448	260	1310	807	1632	800	DN100	DN 80
2K 80/300 + KVCX 65/80	560	1151	782	199	350	318	448	260	1310	807	1632	800	DN100	DN 80
2K 70/400 + KVCX 65/80	560	1151	782	199	350	318	448	260	1310	807	1632	800	DN100	DN 80
2K 80/400 + KVCX 65/80	560	1151	782	199	350	318	448	260	1310	807	1632	800	DN100	DN 80

* The sizes are for the set with jockey pump. For the sizes of the set without jockey pump, disregard B1, D, and G.
For the weights contact our sales network.

3K - RESIDENTIAL/INDUSTRIAL PRESSURE BOOSTER SETS

Pumped liquid temperature range: from -15 °C to +70 °C - Jockey pump pumped liquid temperature range: from +0 °C to +40 °C.
 Maximum ambient temperature: +40 °C

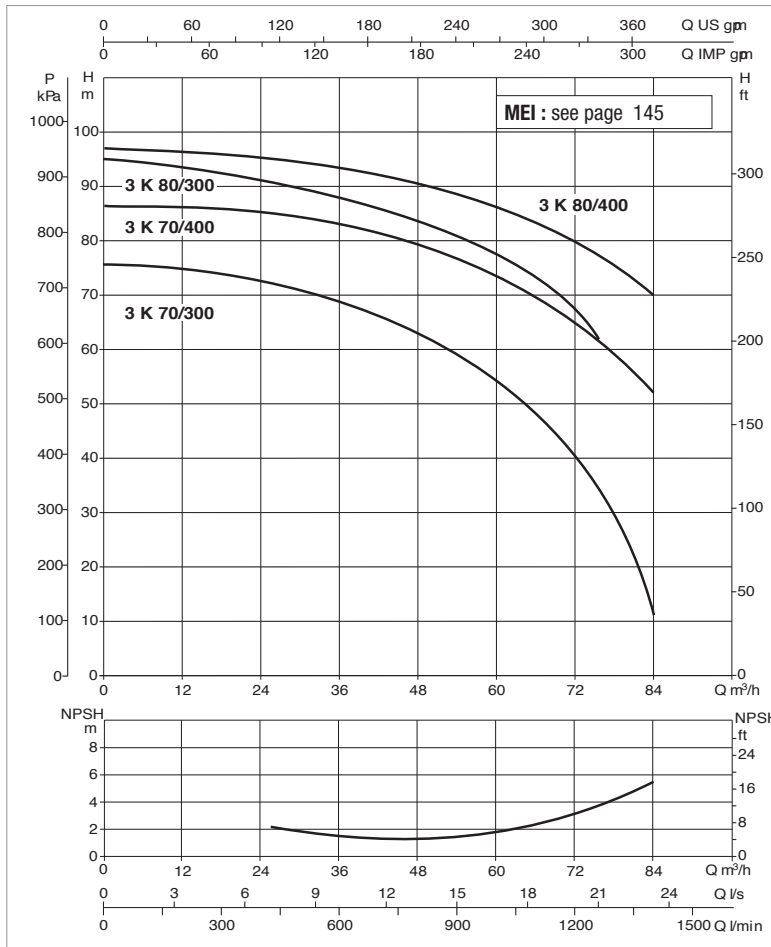
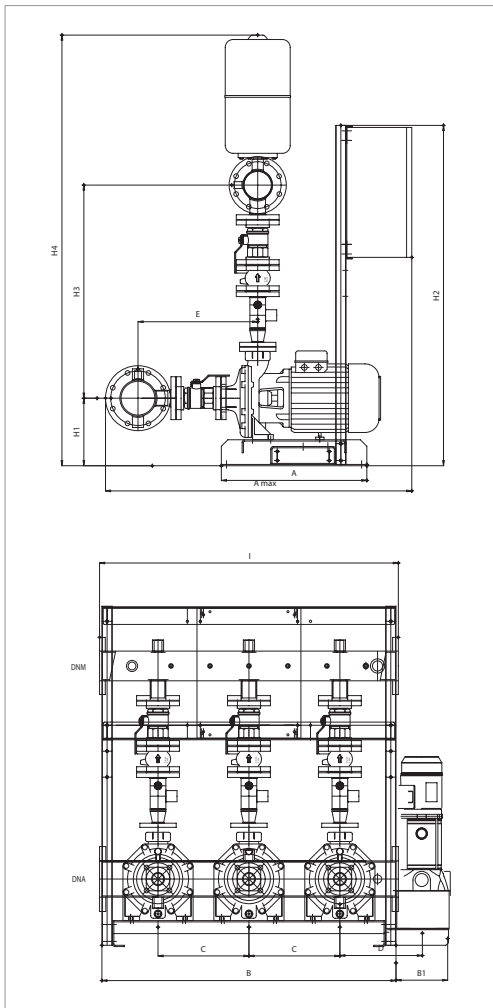

The performance curves are based on kinematic viscosity values = 1 mm²/s and density equivalent to 1000 kg/m³
 Curve tolerance according to ISO 9906.
Overall performance taking into account THREE pumps working at the same time.

MODEL	POWER INPUT 50 Hz	P2 NOMINAL		RATED P2 JOCKEY	In A	FLOW m ³ /h	MAX OBTAINABLE PRESSURE BAR	STANDARD PRESSURE BAR
		kW	HP	kW				
3K 70/300 + KVCX 65/50	3x400 V	3x5,5	3x7,5	1,1	3x12,9	6-66	7,3	6,5
3K 80/300 + KVCX 65/80	3x400 V	3x7,5	3x10	1,1	3x15	6-72	9,2	8,5
3K 70/400 + KVCX 65/80	3x400 V	3x9,2	3x12,5	2,2	3x18	9-90	8,3	7,5
3K 80/400 + KVCX 65/80	3x400 V	3x11	3x15	2,2	3x21	9-90	9,5	8,5

MODEL	A	A max	B	B1*	C	D*	E	H1	H2	H3	H4	I	DNA	DNM
3K 70/300 + KVCX 65/50	560	1179	1132	199	350	318	461	260	1310	820	1657	1150	DN 125	DN 100
3K 80/300 + KVCX 65/80	560	1179	1132	199	350	318	461	260	1310	820	1657	1150	DN 125	DN 100
3K 70/400 + KVCX 65/80	560	1179	1132	199	350	318	461	260	1310	820	1657	1150	DN 125	DN 100
3K 80/400 + KVCX 65/80	560	1179	1132	199	350	318	461	260	1310	820	1657	1150	DN 125	DN 100

* The sizes are for the set with jockey pump. For the sizes of the set without jockey pump, disregard B1, D, and G.
 For the weights contact our sales network.

1 NKP-G 32 - RESIDENTIAL/INDUSTRIAL PRESSURE BOOSTER SETS

Pumped liquid temperature range: from -15 °C to +70 °C - Jockey pump pumped liquid temperature range: from +0 °C to +40 °C.
Maximum ambient temperature: + 40 °C

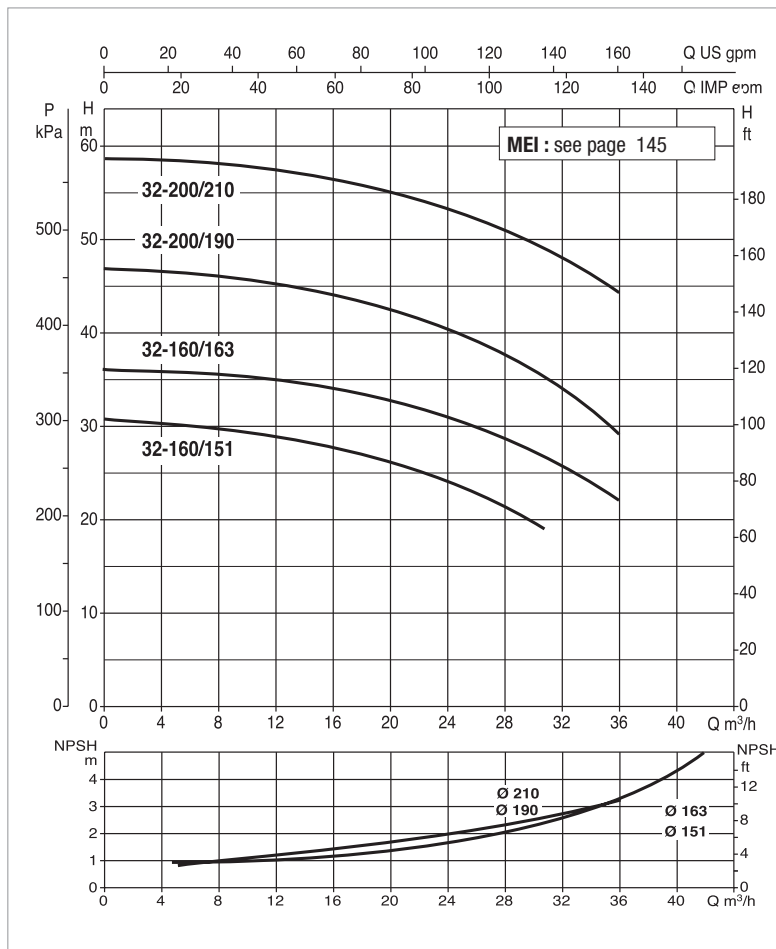
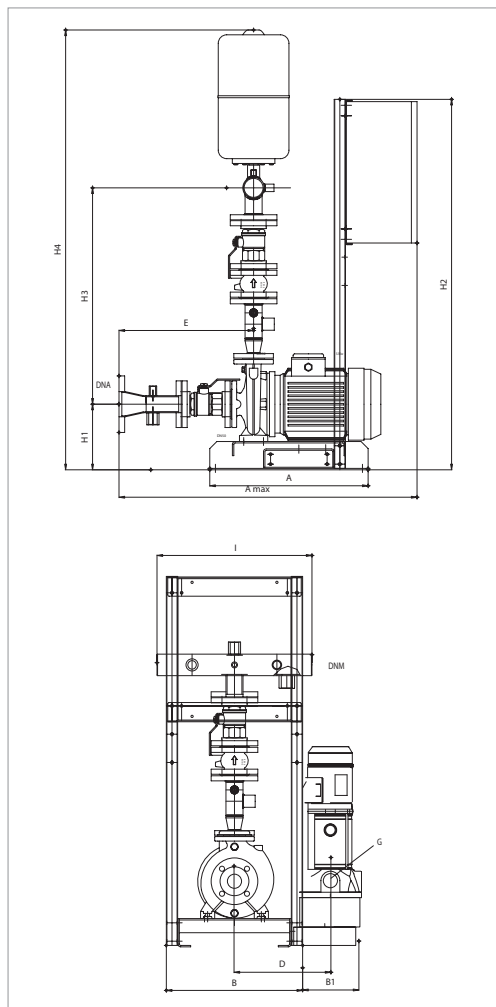

The performance curves are based on kinematic viscosity values = 1 mm²/s and density equivalent to 1000 kg/m³
Curve tolerance according to ISO 9906.

MODEL	POWER INPUT 50 Hz	P2 NOMINAL		RATED P2 JOCKEY	In A	FLOW m ³ /h	MAX OBTAINABLE PRESSURE BAR	STANDARD PRESSURE BAR
		kW	HP	kW				
1 NKP-G 32-160/151 + KVCX 65/50	3x400 V	3	4	1,1	6,7	4-28	3	2,5
1 NKP-G 32-160/163 + KVCX 65/50	3x400 V	4	5,5	1,1	8,7	4-32	3,5	3
1 NKP-G 32-200/190 + KVCX 65/50	3x400 V	5,5	7,5	1,1	11,6	4-32	4,5	4
1 NKP-G 32-200/210 + KVCX 65/50	3x400 V	7,5	10	1,1	14	4-32	5,6	5

MODEL	A	A max	B	B1*	D*	E	G*	H1	H2	H3	H4	I	DNA	DNM
1 NKP-G 32-160/151 + KVCX 65/50	560	1054	482	199	343	476	1"1/4	232	1310	765	1555	548	DN80	2" 1/2
1 NKP-G 32-160/163 + KVCX 65/50	560	1054	482	199	343	476	1"1/4	232	1310	765	1555	548	DN80	2" 1/2
1 NKP-G 32-200/190 + KVCX 65/50	560	1054	482	199	343	476	1"1/4	260	1310	785	1603	548	DN80	2" 1/2
1 NKP-G 32-200/210 + KVCX 65/50	560	1054	482	199	343	476	1"1/4	260	1310	785	1603	548	DN80	2" 1/2

* The sizes are for the set with jockey pump. For the sizes of the set without jockey pump, disregard B1, D, and G.
For the weights contact our sales network.

1 NKP-G 40 - RESIDENTIAL/INDUSTRIAL PRESSURE BOOSTER SETS

Pumped liquid temperature range: from -15 °C to +70 °C - Jockey pump pumped liquid temperature range: from +0 °C to +40 °C.
Maximum ambient temperature: +40 °C

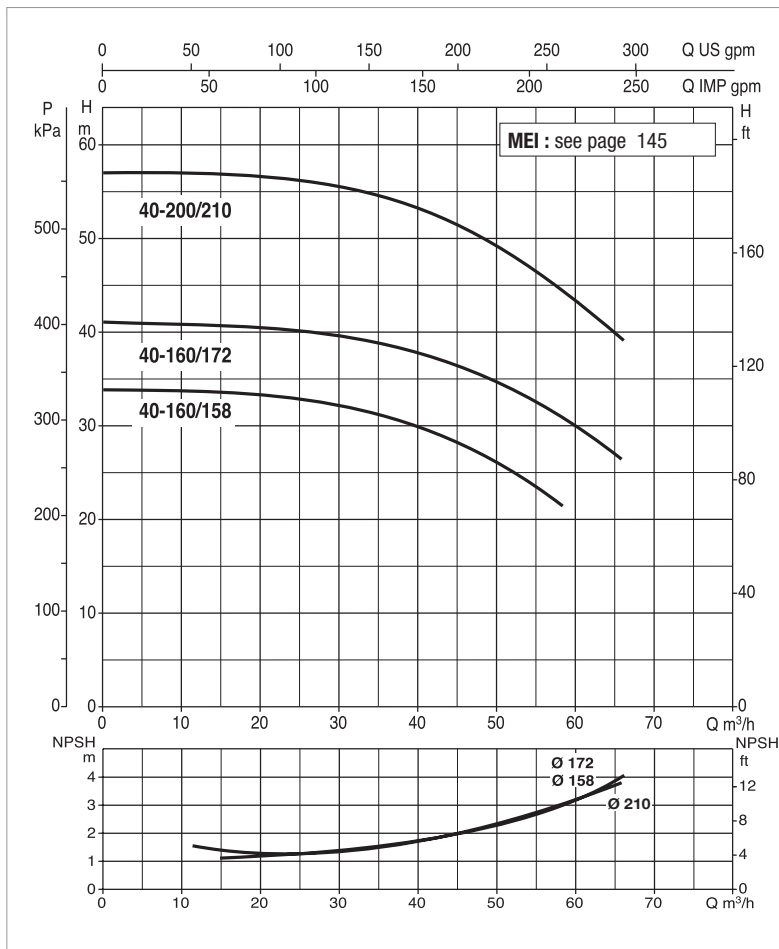
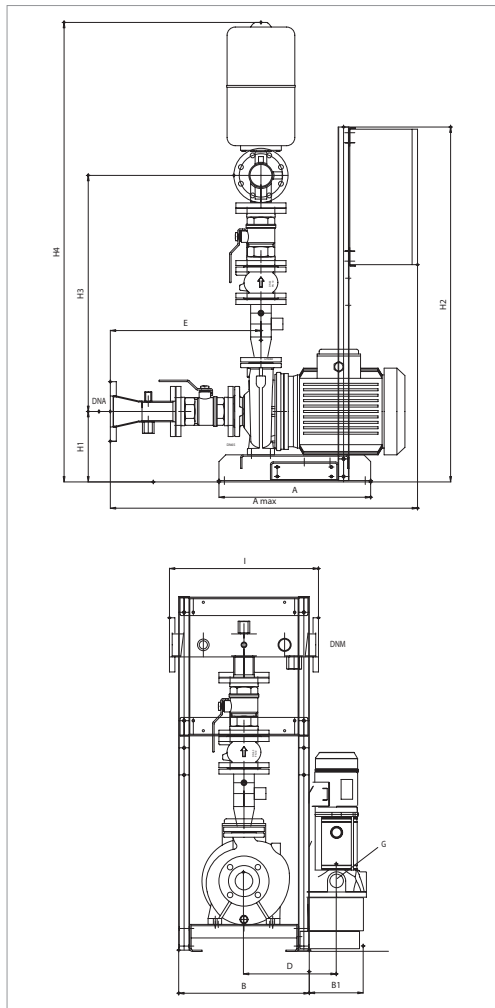

The performance curves are based on kinematic viscosity values = 1 mm²/s and density equivalent to 1000 kg/m³
Curve tolerance according to ISO 9906.

MODEL	POWER INPUT 50 Hz	P2 NOMINAL		RATED P2 JOCKEY	In A	FLOW m ³ /h	MAX OBTAINABLE PRESSURE BAR	STANDARD PRESSURE BAR
		kW	HP	kW				
1 NKP-G 40-160/158 + KVCX 65/50	3x400 V	5,5	7,5	1,1	11,6	10 – 55	3,3	3
1 NKP-G 40-160/172 + KVCX 65/50	3x400 V	7,5	10	1,1	14	10 – 60	4	3,5
1 NKP-G 40-200/210 + KVCX 65/80	3x400 V	11	15	2,2	22,5	10 – 60	5,5	5

MODEL	A	A max	B	B1*	D*	E	G*	H1	H2	H3	H4	I	DNA	DNM
1 NKP-G 40-160/158 + KVCX 65/50	560	1114	482	199	343	536	1" 1/4	232	1310	851	1648	550	DN100	DN80
1 NKP-G 40-160/172 + KVCX 65/50	560	1114	482	199	343	536	1" 1/4	232	1310	851	1648	550	DN100	DN80
1 NKP-G 40-200/210 + KVCX 65/80	560	1114	482	199	343	556	1" 1/4	260	1310	871	1696	550	DN100	DN80

* The sizes are for the set with jockey pump. For the sizes of the set without jockey pump, disregard B1, D, and G.
For the weights contact our sales network.

1 NKP-G 40 - RESIDENTIAL/INDUSTRIAL PRESSURE BOOSTER SETS

Pumped liquid temperature range: from -15 °C to +70 °C - Jockey pump pumped liquid temperature range: from +0 °C to +40 °C.
Maximum ambient temperature: +40 °C

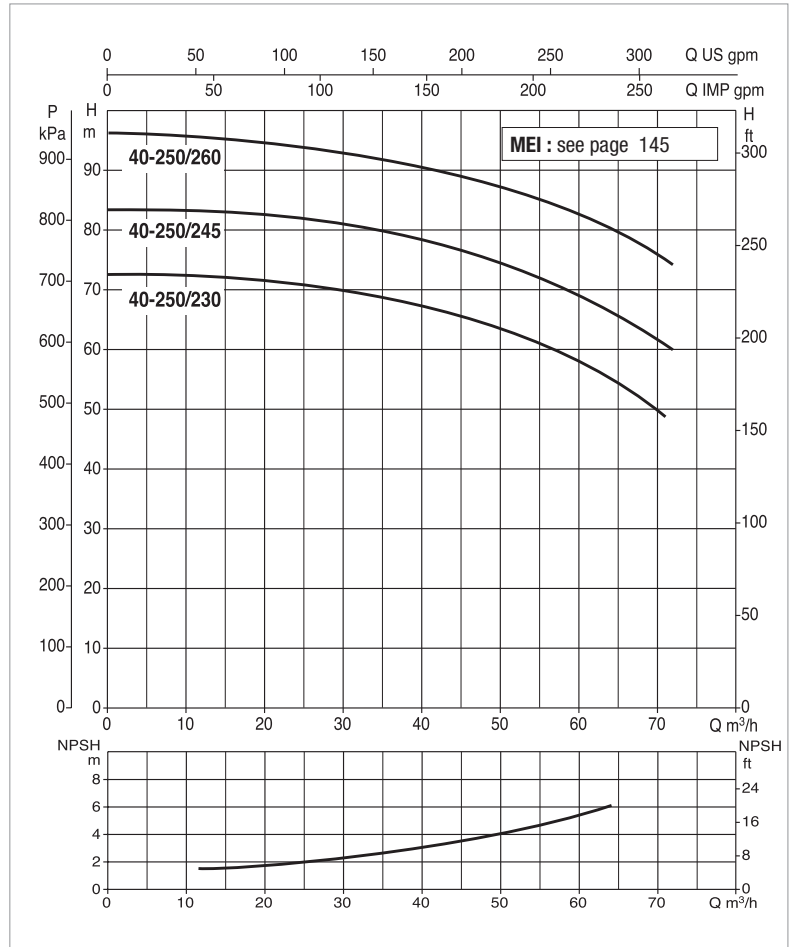
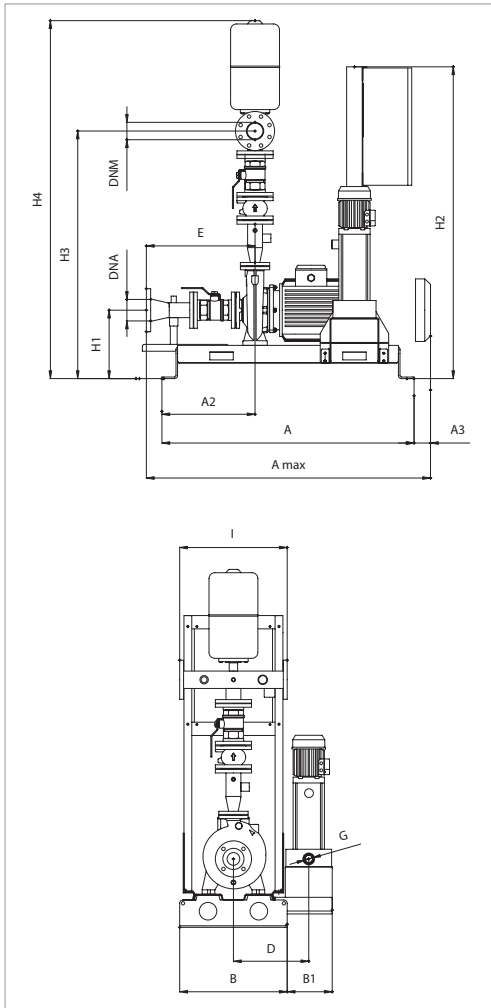

The performance curves are based on kinematic viscosity values = 1 mm²/s and density equivalent to 1000 kg/m³
Curve tolerance according to ISO 9906.

MODEL	POWER INPUT 50 Hz	P2 NOMINAL		RATED P2 JOCKEY	In A	FLOW m ³ /h	MAX OBTAINABLE PRESSURE BAR	STANDARD PRESSURE BAR
		kW	HP	kW				
1 NKP-G 40-250/230 + KVCX 65/80	3x400 V	15	20	2,2	31	10 – 70	7	6,5
1 NKP-G 40-250/245 + KVCX 65/80	3x400 V	18,5	25	2,2	36	10 – 70	8	7,5
1 NKP-G 40-250/260 + KVCX 65/80	3x400 V	22	30	2,2	43	10 – 70	9,3	8,5

MODEL	A max	A	A2	A3	B	B1*	D*	E	G*	I	H1	H2	H3	H4	DNA	DNM
1 NKP-G 40-250/230 + KVCX 65/80	1370	1290	477	-	550	230	385	556	1" 1/4	550	530	1600	1270	1835	DN100	DN80
1 NKP-G 40-250/245 + KVCX 65/80	1290	1290	579	-	550	230	385	556	1" 1/4	550	350	1600	1270	1835	DN100	DN80
1 NKP-G 40-250/260 + KVCX 65/80	1290	1290	579	-	550	230	385	556	1" 1/4	550	350	1600	1270	1835	DN100	DN80

* The sizes are for the set with jockey pump. For the sizes of the set without jockey pump, disregard B1, D, and G.
For the weights contact our sales network.

1 NKP-G 50 - RESIDENTIAL/INDUSTRIAL PRESSURE BOOSTER SETS

Pumped liquid temperature range: from -15 °C to +70 °C - Jockey pump pumped liquid temperature range: from +0 °C to +40 °C.
Maximum ambient temperature: +40 °C

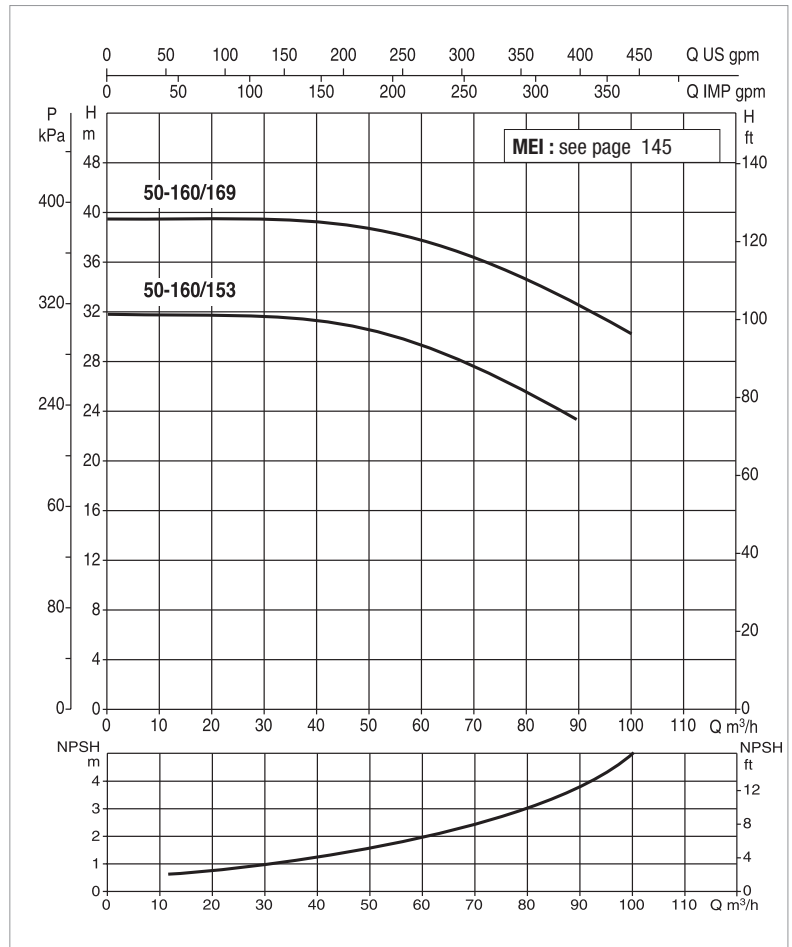
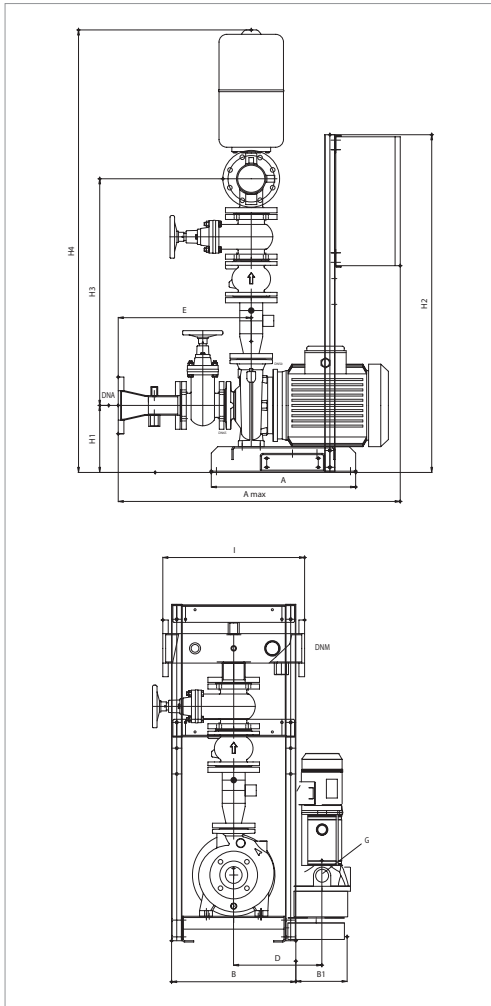

The performance curves are based on kinematic viscosity values = 1 mm²/s and density equivalent to 1000 kg/m³
Curve tolerance according to ISO 9906.

MODEL	POWER INPUT 50 Hz	P2 NOMINAL		RATED P2 JOCKEY	In A	FLOW m ³ /h	MAX OBTAINABLE PRESSURE BAR	STANDARD PRESSURE BAR
		kW	HP	kW				
1 NKP-G 50-160/153 + KVCX 65/50	3x400 V	7,5	10	1,1	14	10 – 80	3	2,5
1 NKP-G 50-160/169 + KVCX 65/80	3x400 V	11	15	2,2	22,5	10 – 90	3,8	3,3

MODEL	A	A max	B	B1*	D*	E	G*	H1	H2	H3	H4	I	DNA	DNM
1 NKP-G 50-160/153 + KVCX 65/50	560	1094	482	199	343	516	1" 1/4	260	1310	879	1716	550	DN100	DN100
1 NKP-G 50-160/169 + KVCX 65/80	560	1094	482	199	343	516	1" 1/4	260	1310	879	1716	550	DN100	DN100

* The sizes are for the set with jockey pump. For the sizes of the set without jockey pump, disregard B1, D, and G.
For the weights contact our sales network.

1 NKP-G 50 - RESIDENTIAL/INDUSTRIAL PRESSURE BOOSTER SETS

Pumped liquid temperature range: from -15 °C to +70 °C - Jockey pump pumped liquid temperature range: from +0 °C to +40 °C.
Maximum ambient temperature: +40 °C

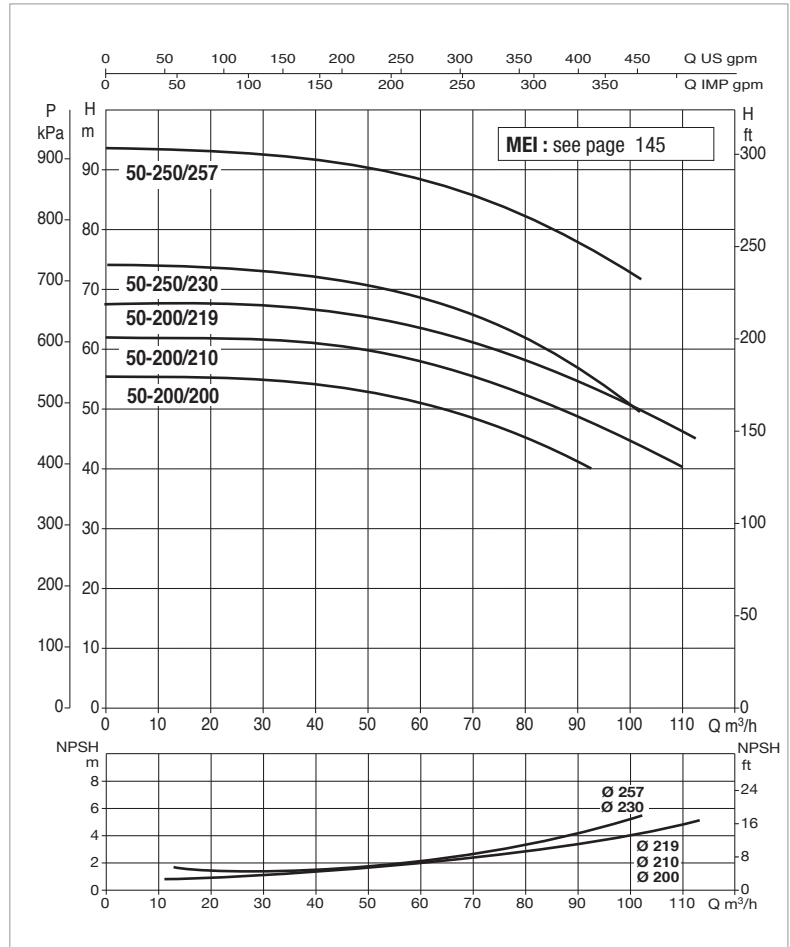
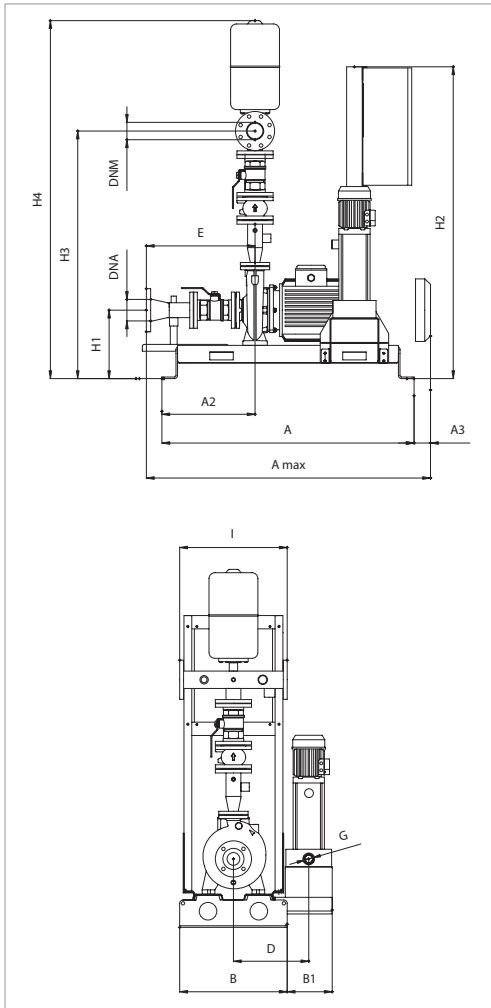

The performance curves are based on kinematic viscosity values = 1 mm²/s and density equivalent to 1000 kg/m³
Curve tolerance according to ISO 9906.

MODEL	POWER INPUT 50 Hz	P2 NOMINAL		RATED P2 JOCKEY	In A	FLOW m ³ /h	MAX OBTAINABLE PRESSURE BAR	STANDARD PRESSURE BAR
		kW	HP	kW				
1 NKP-G 50-200/200 + KVCX 65/80	3x400 V	15	20	2,2	31	10 – 90	5,2	5
1 NKP-G 50-200/210 + KVCX 65/80	3x400 V	18,5	25	2,2	36	10 – 110	6	5,5
1 NKP-G 50-200/219 + KVCX 65/80	3x400 V	22	30	2,2	43	10 – 110	6,5	6
1 NKP-G 50-250/230 + KVCX 65/80	3x400 V	22	30	2,2	43	10 – 100	7	6,5
1 NKP-G 50-250/257 + KVCX 65/80	3x400 V	30	40	2,2	57	10 – 100	9	8,5

MODEL	A max	A	A2	A3	B	B1*	D*	E	G*	I	H1	H2	H3	H4	DNA	DNM
1 NKP-G 50-200/200 + KVCX 65/80	1372	1290	434	-	550	230	385	516	1" 1/4	550	330	1600	1230	1805	DN100	DN100
1 NKP-G 50-200/210 + KVCX 65/80	1290	1290	579	-	550	230	385	516	1" 1/4	550	330	1600	1230	1805	DN100	DN100
1 NKP-G 50-200/219 + KVCX 65/80	1290	1290	579	-	550	230	385	516	1" 1/4	550	330	1600	1230	1805	DN100	DN100
1 NKP-G 50-250/230 + KVCX 65/80	1290	12990	579	-	550	230	385	516	1" 1/4	550	350	1600	1275	1855	DN100	DN100
1 NKP-G 50-250/257 + KVCX 65/80	1290	12990	579	-	550	230	385	516	1" 1/4	550	350	1600	1275	1855	DN100	DN100

* The sizes are for the set with jockey pump. For the sizes of the set without jockey pump, disregard B1, D, and G.
For the weights contact our sales network.

1 NKP-G 65 - RESIDENTIAL/INDUSTRIAL PRESSURE BOOSTER SETS

Pumped liquid temperature range: from -15 °C to +70 °C - Jockey pump pumped liquid temperature range: from +0 °C to +40 °C.
Maximum ambient temperature: +40 °C

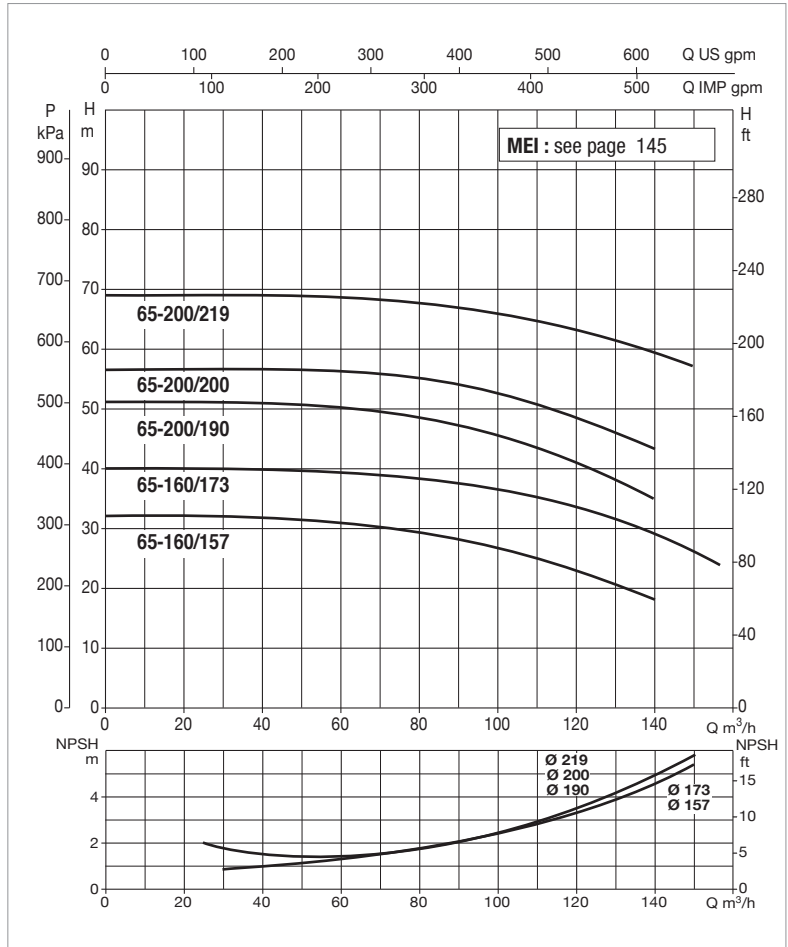
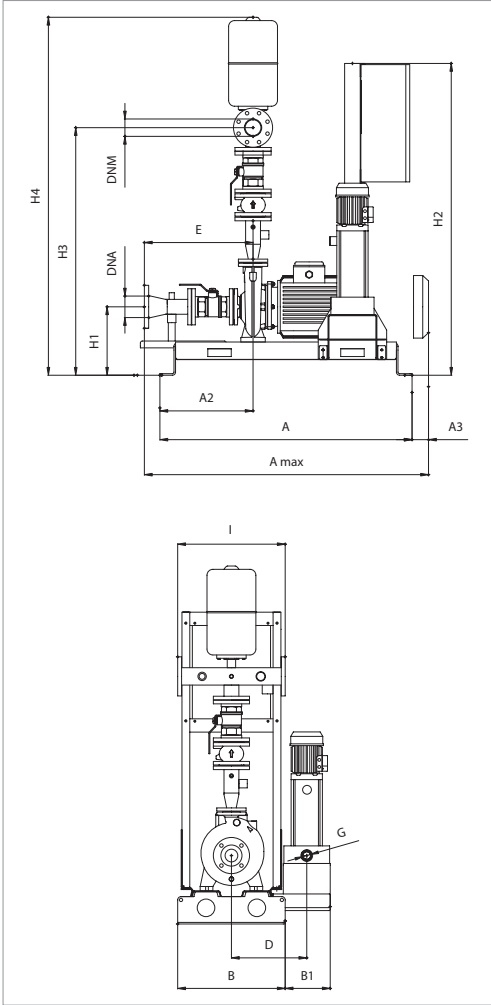

The performance curves are based on kinematic viscosity values = 1 mm²/s and density equivalent to 1000 kg/m³
Curve tolerance according to ISO 9906.

MODEL	POWER INPUT 50 Hz	P2 NOMINAL		RATED P2 JOCKEY	In A	FLOW m ³ /h	MAX OBTAINABLE PRESSURE BAR	STANDARD PRESSURE BAR
		kW	HP	kW				
1 NKP-G 65-160/157 + KVCX 65/80	3x400 V	11	15	2,2	20,4	20 - 140	3	2,5
1 NKP-G 65-160/173 + KVCX 65/80	3x400 V	15	20	2,2	27,5	20 - 150	3,8	3,5
1 NKP-G 65-200/190 + KVCX 65/80	3x400 V	18,5	25	2,2	33,5	20 - 140	5	4,5
1 NKP-G 65-200/200 + KVCX 65/80	3x400 V	22	30	2,2	39,5	20 - 140	5,5	5
1 NKP-G 65-200/219 + KVCX 65/80	3x400 V	30	40	2,2	52,5	20 - 140	6,5	6

MODEL	A max	A	A2	A3	B	B1*	D*	E	G*	I	H1	H2	H3	H4	DNA	DNM
1 NKP-G 65-160/157 + KVCX 65/80	1400	1290	445	-	550	230	385	556	1" 1/4	550	350	1600	1320	1910	DN125	DN125
1 NKP-G 65-160/173 + KVCX 65/80	1400	1290	445	-	550	230	385	556	1" 1/4	550	350	1600	1320	1910	DN125	DN125
1 NKP-G 65-200/190 + KVCX 65/80	1400	1290	445	-	550	230	385	556	1" 1/4	550	350	1600	1345	1935	DN125	DN125
1 NKP-G 65-200/200 + KVCX 65/80	1380	1290	511	45	550	230	385	556	1" 1/4	550	350	1600	1345	1935	DN125	DN125
1 NKP-G 65-200/219 + KVCX 65/80	1440	1290	464	60	550	230	385	556	1" 1/4	550	370	1600	1365	1955	DN125	DN125

* The sizes are for the set with jockey pump. For the sizes of the set without jockey pump, disregard B1, D, and G.
For the weights contact our sales network.

1 NKP-G 80 - RESIDENTIAL/INDUSTRIAL PRESSURE BOOSTER SETS

Pumped liquid temperature range: from -15 °C to +70 °C - Jockey pump pumped liquid temperature range: from +0 °C to +40 °C.
Maximum ambient temperature: +40 °C

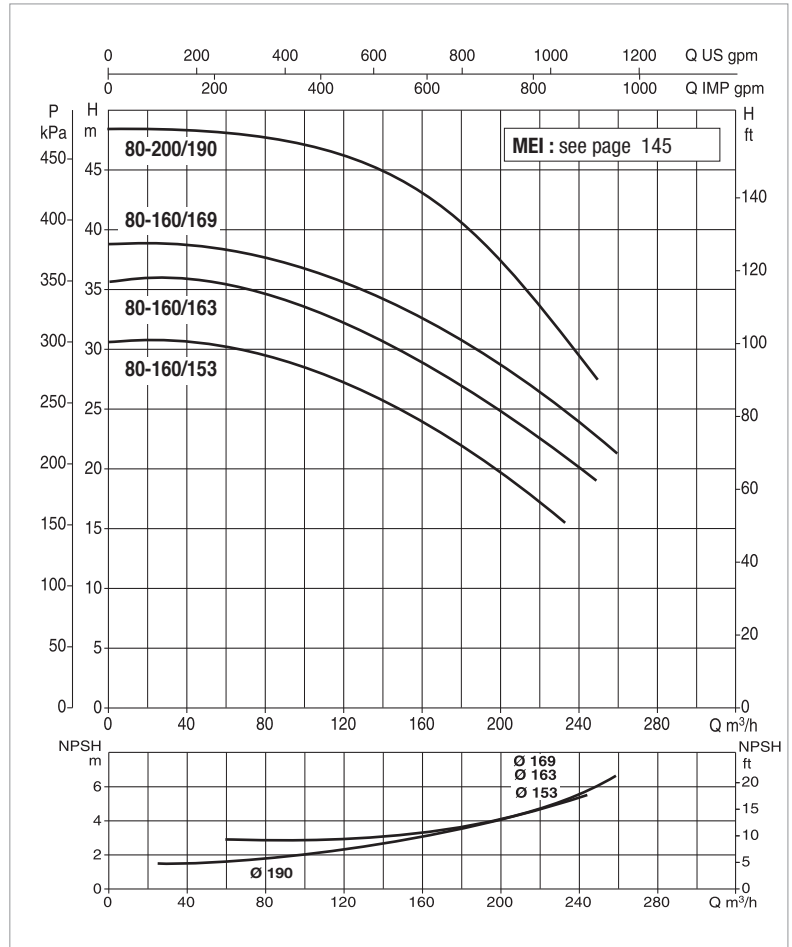
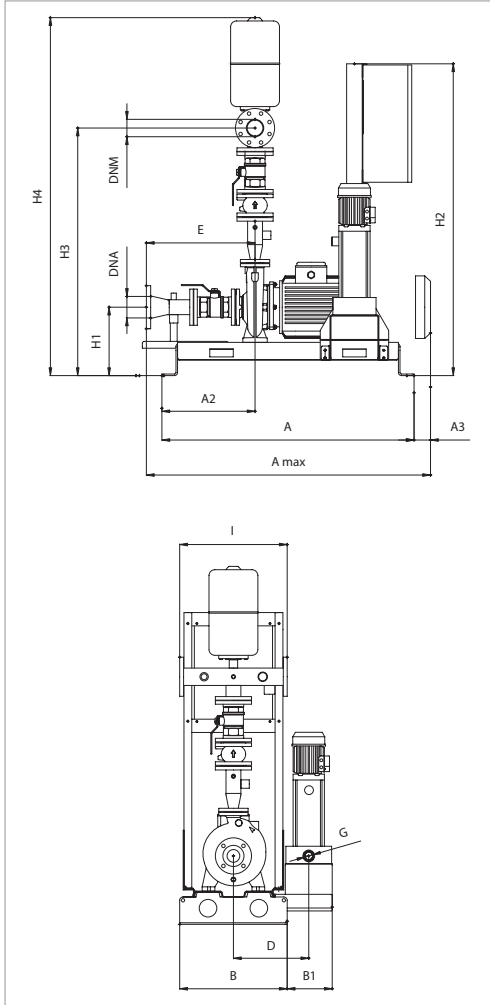

The performance curves are based on kinematic viscosity values = 1 mm²/s and density equivalent to 1000 kg/m³
Curve tolerance according to ISO 9906.

MODEL	POWER INPUT 50 Hz	P2 NOMINAL		RATED P2 JOCKEY	In A	FLOW m ³ /h	MAX OBTAINABLE PRESSURE BAR	STANDARD PRESSURE BAR
		kW	HP	kW				
1 NKP-G 80-160/153 + KVCX 65/80	3x400 V	15	20	2,2	27,5	40 - 220	2,8	2,5
1 NKP-G 80-160/163 + KVCX 65/80	3x400 V	18,5	25	2,2	33,5	40 - 240	3,3	3
1 NKP-G 80-160/169 + KVCX 65/80	3x400 V	22	30	2,2	39,5	40 - 240	3,7	3,3
1 NKP-G 80-200/190 + KVCX 65/80	3x400 V	30	40	2,2	52,5	40 - 240	4,6	4,5

MODEL	A max	A	A2	A3	B	B1*	D*	E	G*	I	H1	H2	H3	H4	DNA	DNM
1NKP-G 80-160/153 + KVCX 65/80	1445	1290	445	-	550	230	385	596	1" 1/4	550	350	1600	1435	2040	DN150	DN150
1NKP-G 80-160/163 + KVCX 65/80	1445	1290	445	-	550	230	385	596	1" 1/4	550	350	1600	1435	2040	DN150	DN150
1NKP-G 80-160/169 + KVCX 65/80	1420	1290	511	45	550	230	385	596	1" 1/4	550	350	1600	1435	2040	DN150	DN150
1NKP-G 80-200/190 + KVCX 65/80	1510	1290	434	60	550	230	385	596	1" 1/4	550	370	1600	1480	2085	DN150	DN150

* The sizes are for the set with jockey pump. For the sizes of the set without jockey pump, disregard B1, D, and G.
For the weights contact our sales network.

2 NKP-G 32 - RESIDENTIAL/INDUSTRIAL PRESSURE BOOSTER SETS

Pumped liquid temperature range: from -15 °C to +70 °C - Jockey pump pumped liquid temperature range: from +0 °C to +40 °C.
Maximum ambient temperature: +40 °C

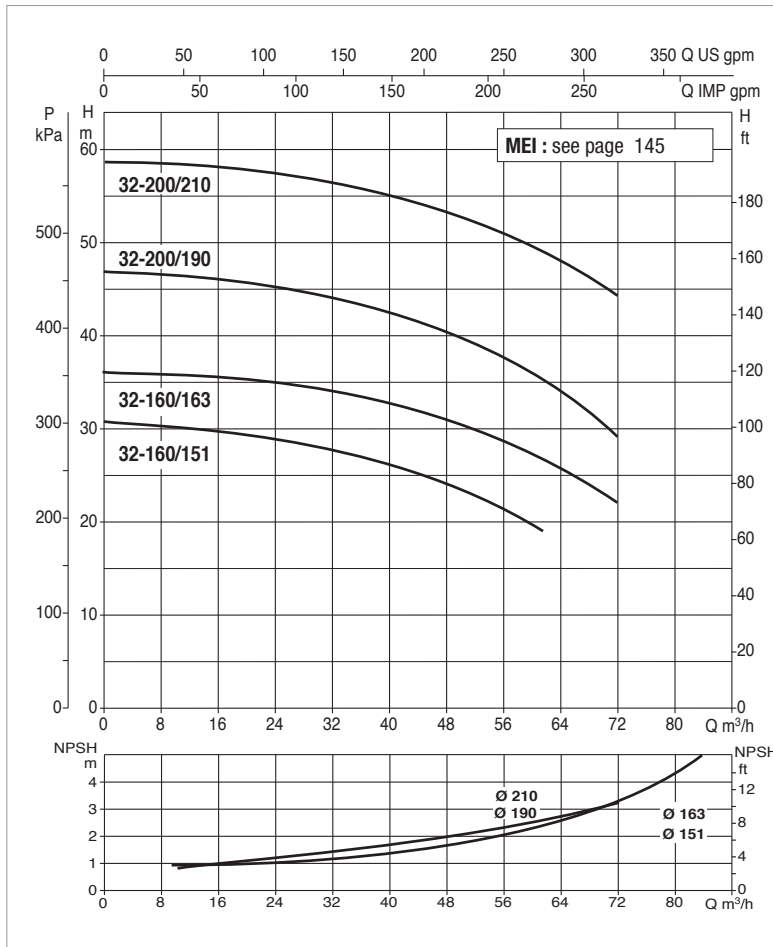
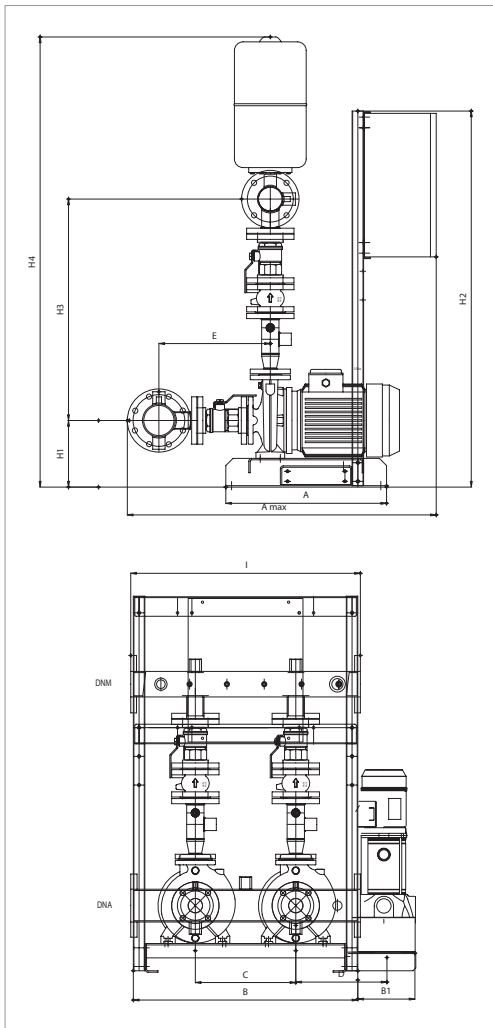

The performance curves are based on kinematic viscosity values = 1 mm²/s and density equivalent to 1000 kg/m³
Curve tolerance according to ISO 9906.
Overall performance taking into account TWO pumps working at the same time.

MODEL	POWER INPUT 50 Hz	P2 NOMINAL		RATED P2 JOCKEY	In A	FLOW m ³ /h	MAX OBTAINABLE PRESSURE BAR	STANDARD PRESSURE BAR
		kW	HP	kW				
2NKP-G 32-160/151 + KVCX 65/50	3x400 V	2 x 3	2 x 4	1,1	2 x 6,7	4 - 56	3	2,5
2NKP-G 32-160/163 + KVCX 65/50	3x400 V	2 x 4	2 x 5,5	1,1	2 x 8,7	4 - 64	3,5	3
2NKP-G 32-200/190 + KVCX 65/50	3x400 V	2 x 5,5	2 x 7,5	1,1	2 x 11,6	4 - 64	4,5	4
2NKP-G 32-200/210 + KVCX 65/50	3x400 V	2 x 7,5	2 x 10	1,1	2 x 14	4 - 64	5,6	5

MODEL	A	A max	B	B1*	C	D*	E	H1	H2	H3	H4	I	DNA	DNM
2NKP-G 32-160/151 + KVCX 65/50	560	1078	782	199	350	318	388	232	1310	771	1568	800	DN100	DN80
2NKP-G 32-160/163 + KVCX 65/50	560	1078	782	199	350	318	388	232	1310	771	1568	800	DN100	DN80
2NKP-G 32-200/190 + KVCX 65/50	560	1078	782	199	350	318	388	260	1310	791	1616	800	DN100	DN80
2NKP-G 32-200/210 + KVCX 65/50	560	1078	782	199	350	318	388	260	1310	791	1616	800	DN100	DN80

* The sizes are for the set with jockey pump. For the sizes of the set without jockey pump, disregard B1, D, and G.
For the weights contact our sales network.

2 NKP-G 40 - RESIDENTIAL/INDUSTRIAL PRESSURE BOOSTER SETS

Pumped liquid temperature range: from -15 °C to +70 °C - Jockey pump pumped liquid temperature range: from +0 °C to +40 °C.
Maximum ambient temperature: +40 °C

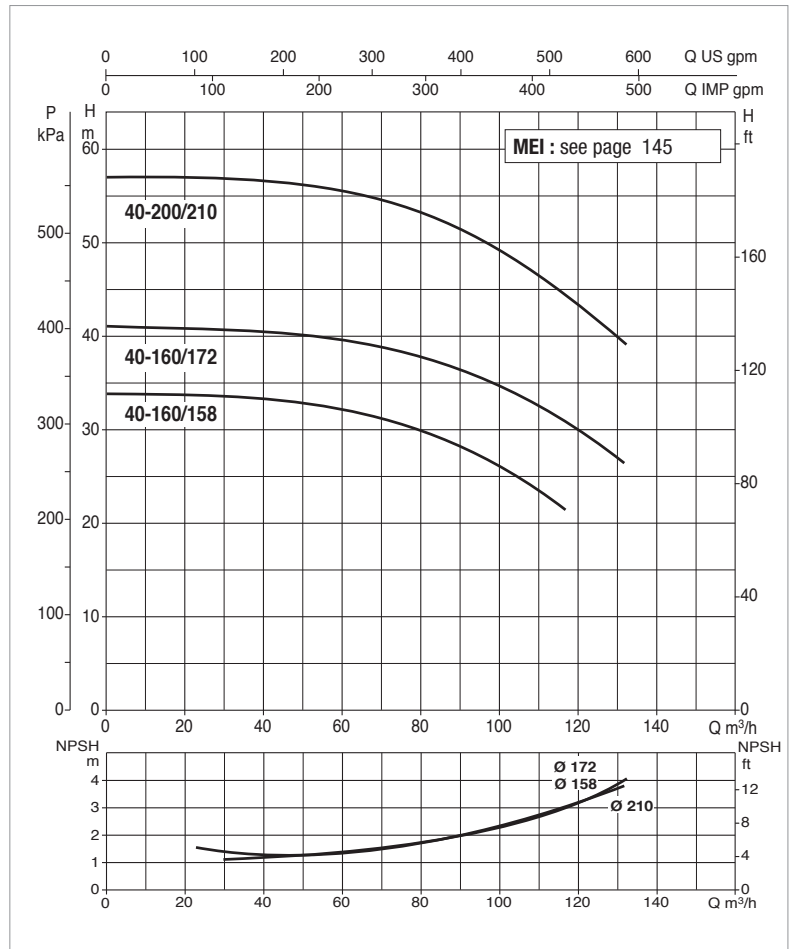
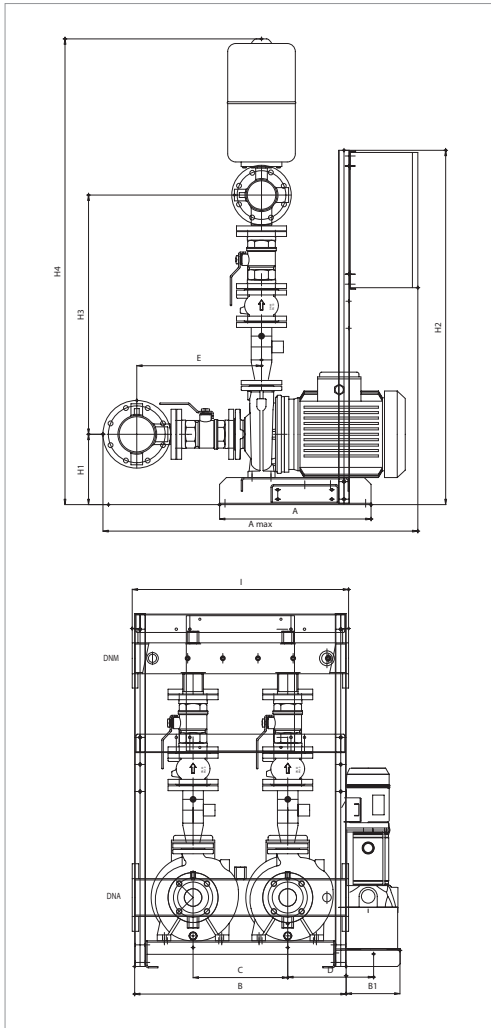

The performance curves are based on kinematic viscosity values = 1 mm²/s and density equivalent to 1000 kg/m³
Curve tolerance according to ISO 9906.
Overall performance taking into account TWO pumps working at the same time.

MODEL	POWER INPUT 50 Hz	P2 NOMINAL		RATED P2 JOCKEY	In A	FLOW m ³ /h	MAX OBTAINABLE PRESSURE BAR	STANDARD PRESSURE BAR
		kW	HP	kW				
2NKP-G 40-160/158 + KVCX 65/50	3x400 V	2x5,5	2x7,5	1,1	2x11,6	10 – 110	3,3	3
2NKP-G 40-160/172 + KVCX 65/50	3x400 V	2x7,5	2x10	1,1	2x14	10 – 120	4	3,5
2NKP-G 40-200/210 + KVCX 65/80	3x400 V	2x11	2x15	2,2	2x22,5	10 – 120	5,5	5

MODEL	A	A max	B	B1*	C	D*	E	H1	H2	H3	H4	I	DNA	DNM
2NKP-G 40-160/158 + KVCX 65/50	560	1144	782	199	350	318	441	232	1310	865	1674	800	DN125	DN100
2NKP-G 40-160/172 + KVCX 65/50	560	1144	782	199	350	318	441	232	1310	865	1674	800	DN125	DN100
2NKP-G 40-200/210 + KVCX 65/80	560	1164	782	199	350	318	461	260	1310	885	1772	800	DN125	DN100

* The sizes are for the set with jockey pump. For the sizes of the set without jockey pump, disregard B1, D, and G.
For the weights contact our sales network.

2 NKP-G 40 - RESIDENTIAL/INDUSTRIAL PRESSURE BOOSTER SETS

Pumped liquid temperature range: from -15 °C to +70 °C - Jockey pump pumped liquid temperature range: from +0 °C to +40 °C.
Maximum ambient temperature: +40 °C

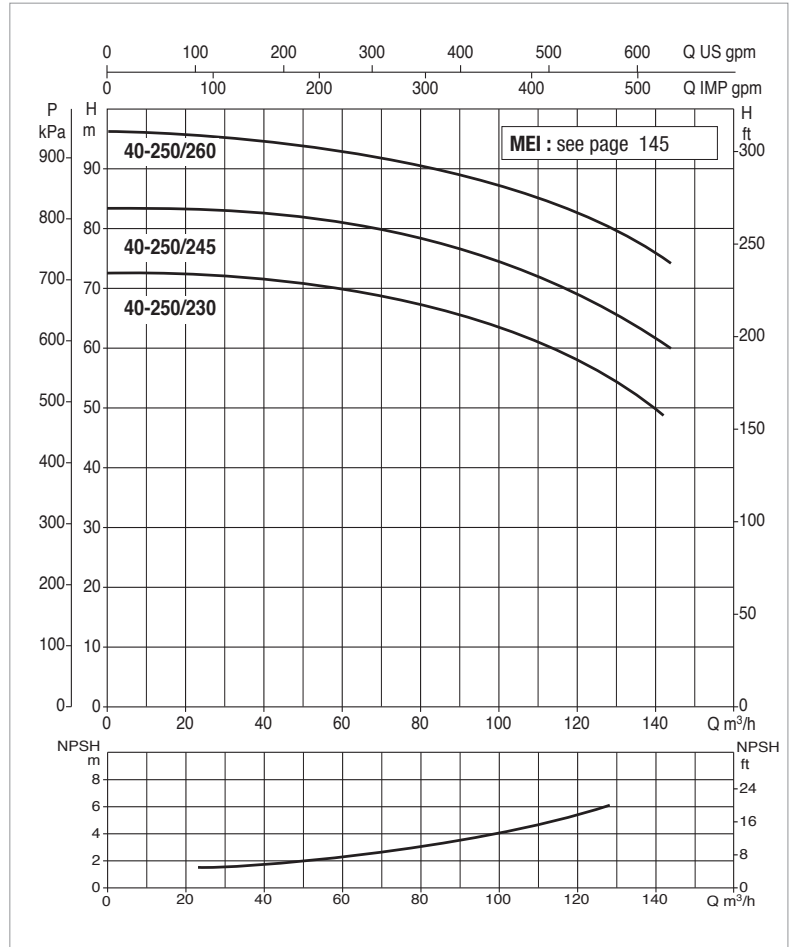
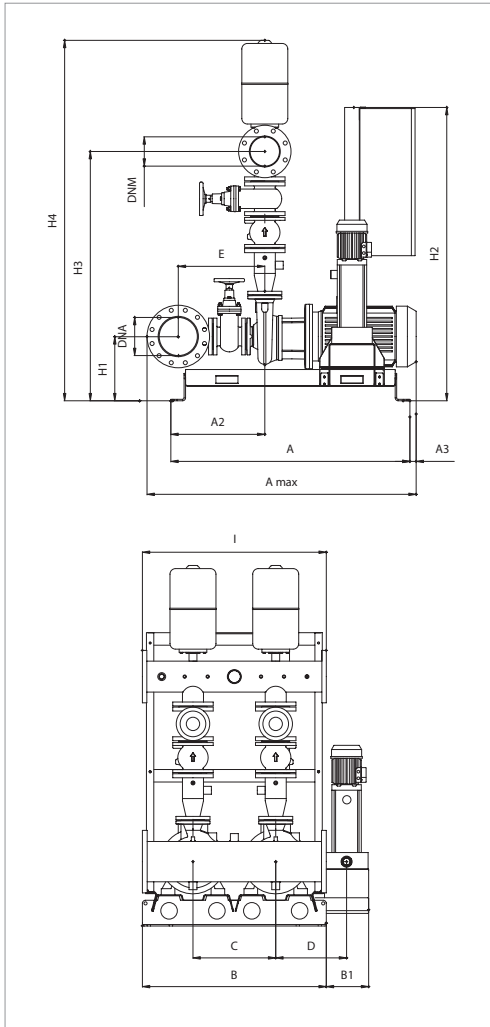

The performance curves are based on kinematic viscosity values = 1 mm²/s and density equivalent to 1000 kg/m³
Curve tolerance according to ISO 9906.
Overall performance taking into account TWO pumps working at the same time.

MODEL	POWER INPUT 50 Hz	P2 NOMINAL		RATED P2 JOCKEY	In A	FLOW m ³ /h	MAX OBTAINABLE PRESSURE BAR	STANDARD PRESSURE BAR
		KW	HP	KW				
2NKP-G 40-250/230 + KVCX 65/80	3x400 V	2 x 15	2 x 20	2,2	2 x 31	10 – 140	7	6,5
2NKP-G 40-250/245 + KVCX 65/80	3x400 V	2 x 18,5	2 x 25	2,2	2 x 36	10 – 140	8	7,5
2NKP-G 40-250/260 + KVCX 65/80	3x400 V	2 x 22	2 x 30	2,2	2 x 43	10 – 140	9,3	8,5

MODEL	A max	A	A2	A3	B	B1*	C	D*	E	I	H1	H2	H3	H4	DNA	DNM
2NKP-G 40-250/230 + KVCX 65/80	1400	1290	477	-	1000	230	450	385	460	1000	350	1600	1280	1860	DN125	DN100
2NKP-G 40-250/245 + KVCX 65/80	1300	1290	579	-	1000	230	450	385	460	1000	350	1600	1280	1860	DN125	DN100
2NKP-G 40-250/260 + KVCX 65/80	1300	1290	579	-	1000	230	450	385	460	1000	350	1600	1280	1860	DN125	DN100

* The sizes are for the set with jockey pump. For the sizes of the set without jockey pump, disregard B1, D, and G.
For the weights contact our sales network.

2 NKP-G 50 - RESIDENTIAL/INDUSTRIAL PRESSURE BOOSTER SETS

Pumped liquid temperature range: from -15 °C to +70 °C - Jockey pump pumped liquid temperature range: from +0 °C to +40 °C.
Maximum ambient temperature: +40 °C

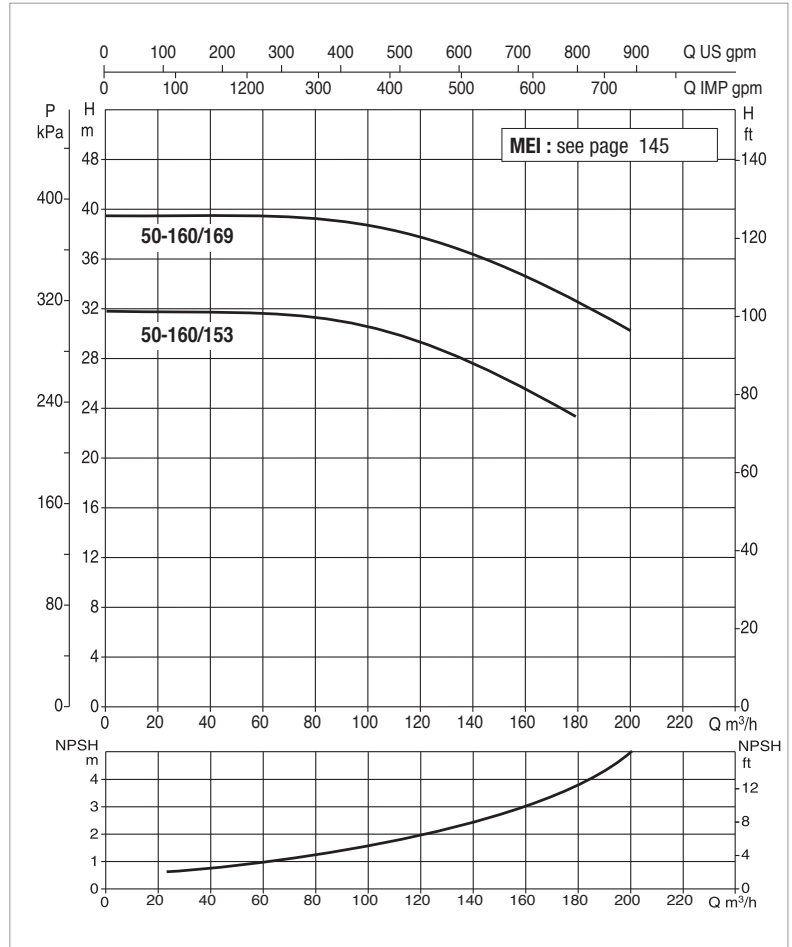
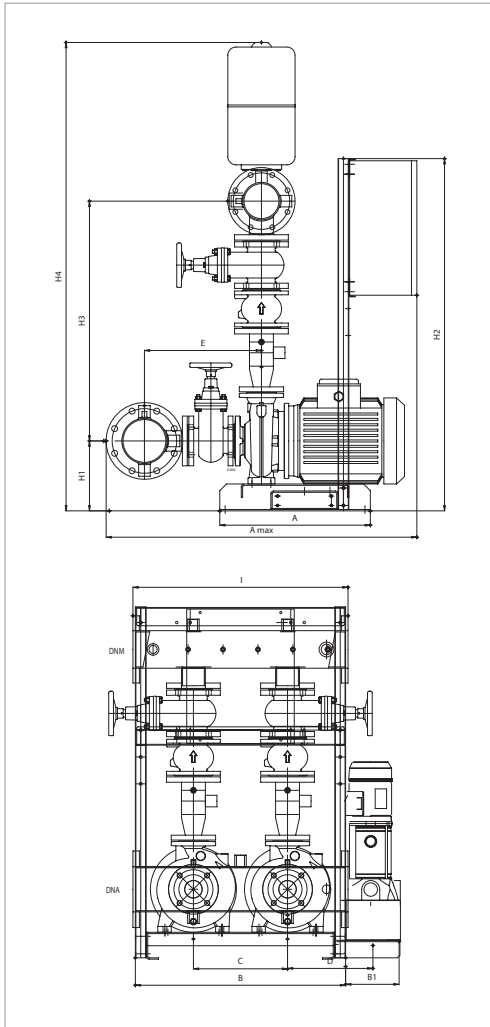

The performance curves are based on kinematic viscosity values = 1 mm²/s and density equivalent to 1000 kg/m³
Curve tolerance according to ISO 9906.
Overall performance taking into account TWO pumps working at the same time.

MODEL	POWER INPUT 50 Hz	P2 NOMINAL		RATED P2 JOCKEY	In A	FLOW m ³ /h	MAX OBTAINABLE PRESSURE BAR	STANDARD PRESSURE BAR
		kW	HP	kW				
2NKP-G 50-160/153 + KVCX 65/50	3x400 V	2 x 7,5	2 x 10	1,1	2 x 14	10 – 160	3	2,5
2NKP-G 50-160/169 + KVCX 65/80	3x400 V	2 x 11	2 x 15	2,2	2 x 22,5	10 – 180	3,8	3,3

MODEL	A	A max	B	B1*	C	D*	E	H1	H2	H3	H4	I	DNA	DNM
2NKP-G 50-160/153 + KVCX 65/50	560	1156	782	199	350	318	435	260	1310	892	1742	800	DN150	DN125
2NKP-G 50-160/169 + KVCX 65/80	560	1156	782	199	350	318	435	260	1310	892	1742	800	DN150	DN125

* The sizes are for the set with jockey pump. For the sizes of the set without jockey pump, disregard B1, D, and G.
For the weights contact our sales network.

2 NKP-G 50 - RESIDENTIAL/INDUSTRIAL PRESSURE BOOSTER SETS

Pumped liquid temperature range: from -15 °C to +70 °C - Jockey pump pumped liquid temperature range: from +0 °C to +40 °C.
Maximum ambient temperature: +40 °C

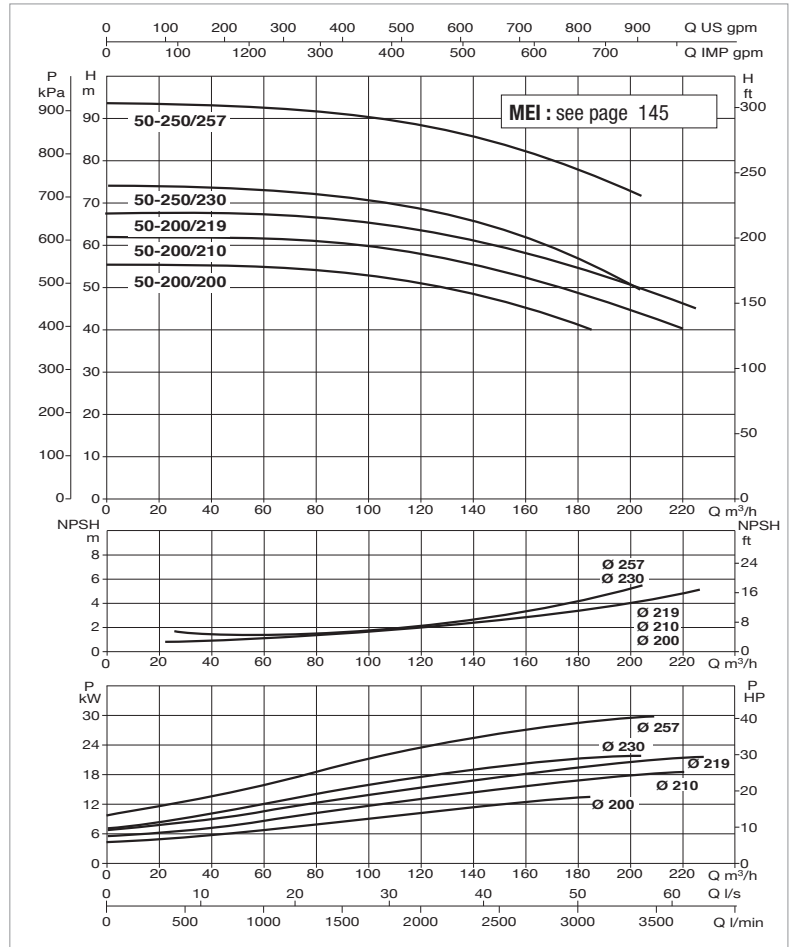
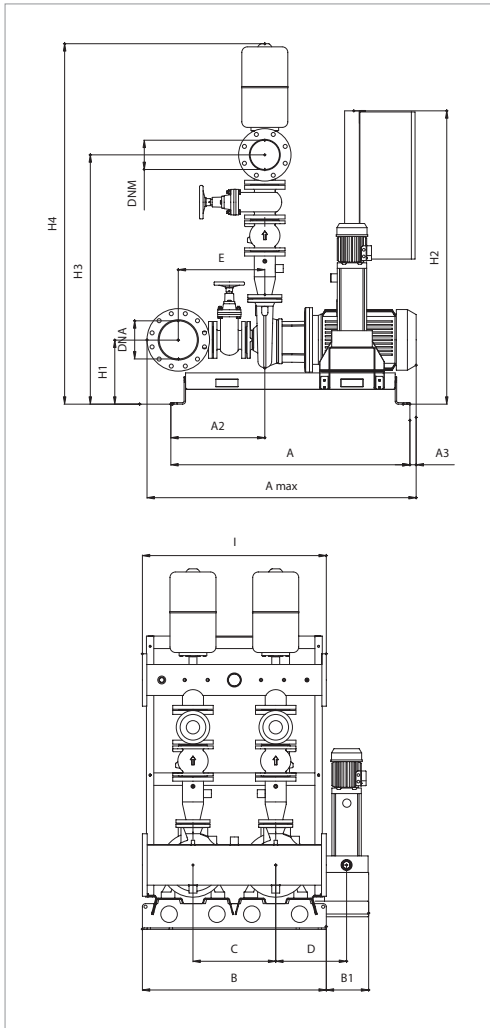

The performance curves are based on kinematic viscosity values = 1 mm²/s and density equivalent to 1000 kg/m³
Curve tolerance according to ISO 9906.
Overall performance taking into account TWO pumps working at the same time.

MODEL	POWER INPUT 50 Hz	P2 NOMINAL		RATED P2 JOCKEY	In A	FLOW m ³ /h	MAX OBTAINABLE PRESSURE BAR	STANDARD PRESSURE BAR
		KW	HP	KW				
2NKP-G 50-200/200 + KVCX 65/80	3x400 V	2 x 15	2 x 20	2,2	2 x 31	10 – 180	5,2	5
2NKP-G 50-200/210 + KVCX 65/80	3x400 V	2 x 18,5	2 x 25	2,2	2 x 36	10 – 220	6	5,5
2NKP-G 50-200/219 + KVCX 65/80	3x400 V	2 x 22	2 x 30	2,2	2 x 43	10 – 220	6,5	6
2NKP-G 50-250/230 + KVCX 65/80	3x400 V	2 x 22	2 x 30	2,2	2 x 43	10 – 200	7	6,5
2NKP-G 50-250/257 + KVCX 65/80	3x400 V	2 x 30	2 x 40	2,2	2 x 57	10 – 200	9	8,5

MODEL	A max	A	A2	B	B1*	C	D*	E	I	H1	H2	H3	H4	DNA	DNM
2NKP-G 50-200/200 + KVCX 65/80	1440	1290	434	1000	230	450	385	435	1000	330	1600	1245	1835	DN150	DN125
2NKP-G 50-200/210 + KVCX 65/80	1290	1290	579	1000	230	450	385	435	1000	330	1600	1245	1835	DN150	DN125
2NKP-G 50-200/219 + KVCX 65/80	1290	1290	579	1000	230	450	385	435	1000	330	1600	1245	1835	DN150	DN125
2NKP-G 50-250/230 + KVCX 65/80	1290	1290	579	1000	230	450	385	435	1000	350	1600	1290	1880	DN150	DN125
2NKP-G 50-250/257 + KVCX 65/80	1290	1290	579	1000	230	450	385	435	1000	350	1600	1290	1880	DN150	DN125

* The sizes are for the set with jockey pump. For the sizes of the set without jockey pump, disregard B1, D, and G.
For the weights contact our sales network.

2 NKP-G 65 - RESIDENTIAL/INDUSTRIAL PRESSURE BOOSTER SETS

Pumped liquid temperature range: from -15 °C to +70 °C - Jockey pump pumped liquid temperature range: from +0 °C to +40 °C.
Maximum ambient temperature: +40 °C

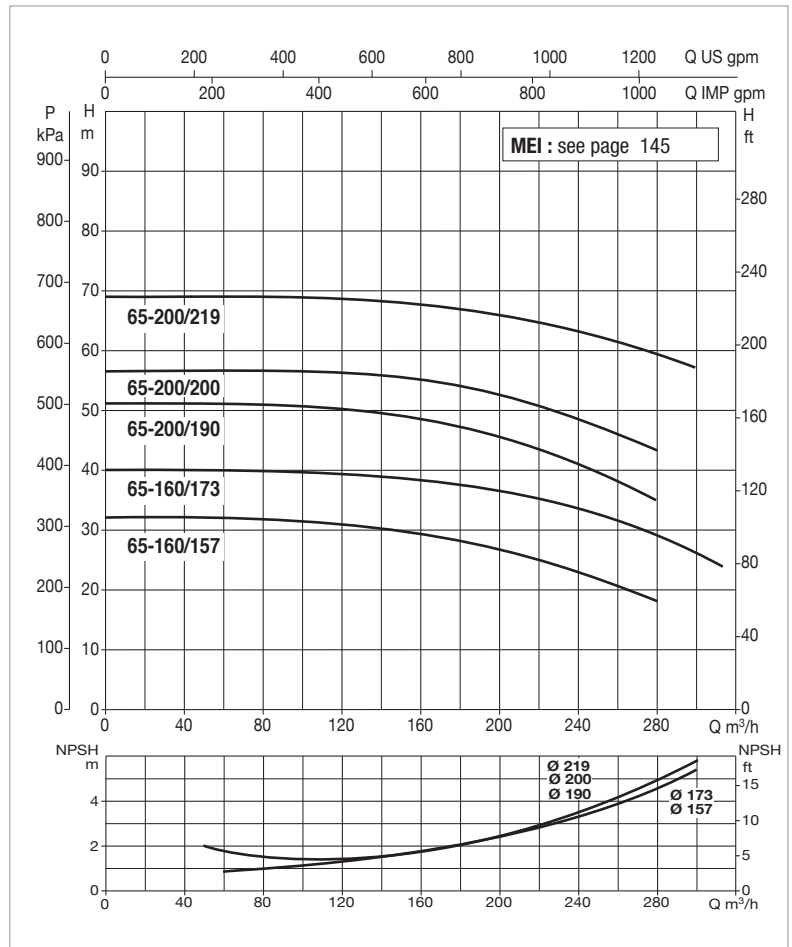
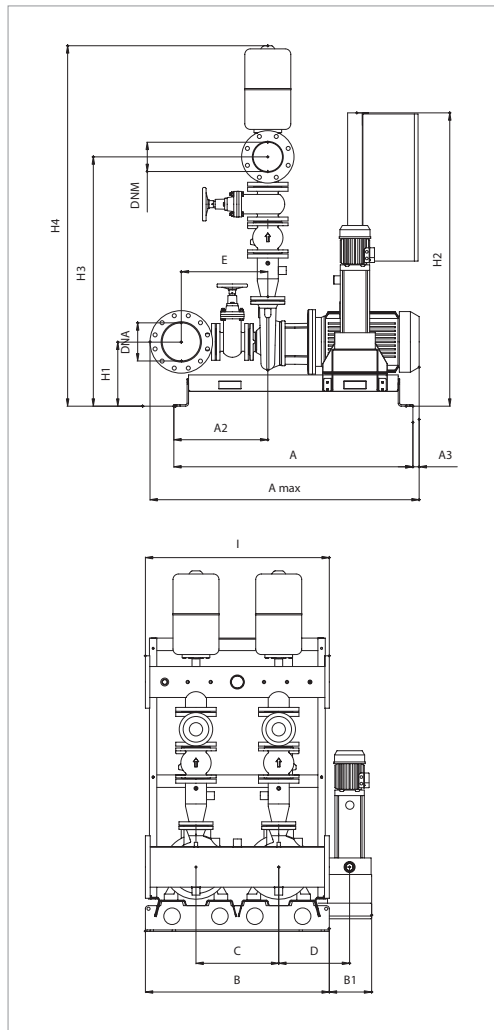

The performance curves are based on kinematic viscosity values = 1 mm²/s and density equivalent to 1000 kg/m³
Curve tolerance according to ISO 9906.
Overall performance taking into account TWO pumps working at the same time.

MODEL	POWER INPUT 50 Hz	P2 NOMINAL		RATED P2 JOCKEY	In A	FLOW m ³ /h	MAX OBTAINABLE PRESSURE BAR	STANDARD PRESSURE BAR
		kW	HP	kW				
2NKP-G 65-160/157 + KVCX 65/80	3x400 V	2 x 11	2 x 15	2,2	2 x 20,4	20 - 280	3	2,5
2NKP-G 65-160/173 + KVCX 65/80	3x400 V	2 x 15	2 x 20	2,2	2 x 27,5	20 - 300	3,8	3,5
2NKP-G 65-200/190 + KVCX 65/80	3x400 V	2 x 18,5	2 x 25	2,2	2 x 33,5	20 - 280	5	4,5
2NKP-G 65-200/200 + KVCX 65/80	3x400 V	2 x 22	2 x 30	2,2	2 x 39,5	20 - 280	5,5	5
2NKP-G 65-200/219 + KVCX 65/80	3x400 V	2 x 30	2 x 40	2,2	2 x 52,5	20 - 280	6,5	6

MODEL	A max	A	A2	A3	B	B1*	C	D*	E	I	H1	H2	H3	H4	DNA	DNM
2NKP-G 65-160/157 + KVCX 65/80	1490	1290	445	-	1000	230	450	385	470	1000	350	1600	1335	1940	DN200	DN150
2NKP-G 65-160/173 + KVCX 65/80	1490	1290	445	-	1000	230	450	385	470	1000	350	1600	1335	1940	DN200	DN150
2NKP-G 65-200/190 + KVCX 65/80	1490	1290	445	-	1000	230	450	385	470	1000	350	1600	1360	1965	DN200	DN150
2NKP-G 65-200/200 + KVCX 65/80	1465	1290	511	45	1000	230	450	385	470	1000	350	1600	1360	1965	DN200	DN150
2NKP-G 65-200/219 + KVCX 65/80	1530	1290	464	60	1000	230	450	385	470	1000	370	1600	1380	1985	DN200	DN150

* The sizes are for the set with jockey pump. For the sizes of the set without jockey pump, disregard B1, D, and G.
For the weights contact our sales network.

2 NKP-G 80 - RESIDENTIAL/INDUSTRIAL PRESSURE BOOSTER SETS

Pumped liquid temperature range: from -15 °C to +70 °C - Jockey pump pumped liquid temperature range: from +0 °C to +40 °C.
Maximum ambient temperature: +40 °C

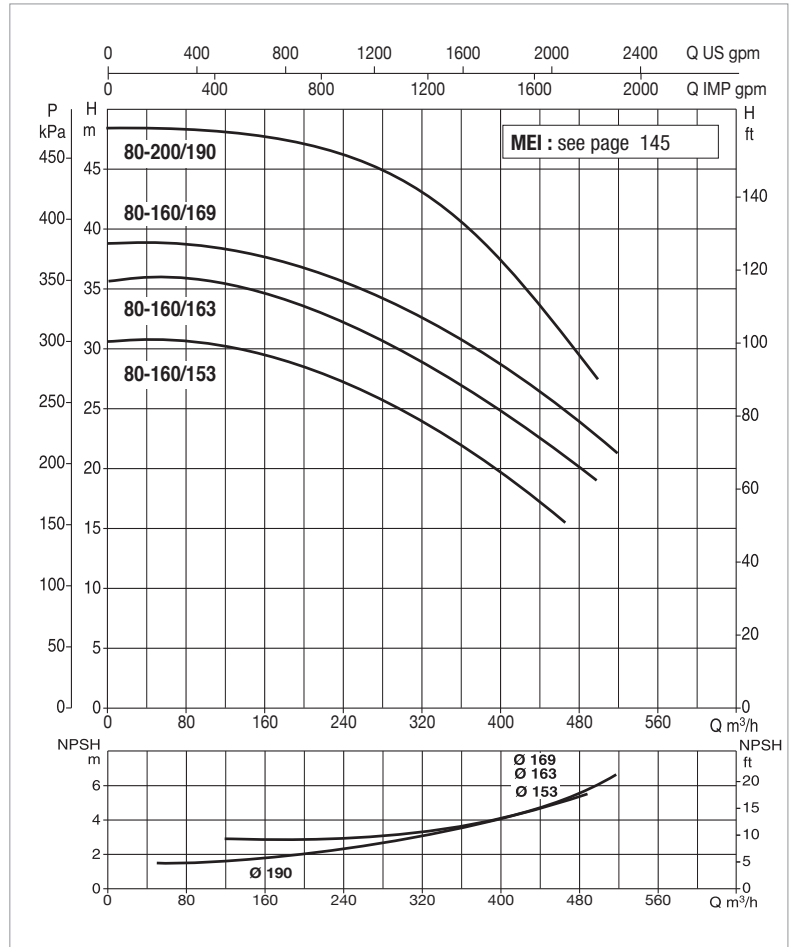
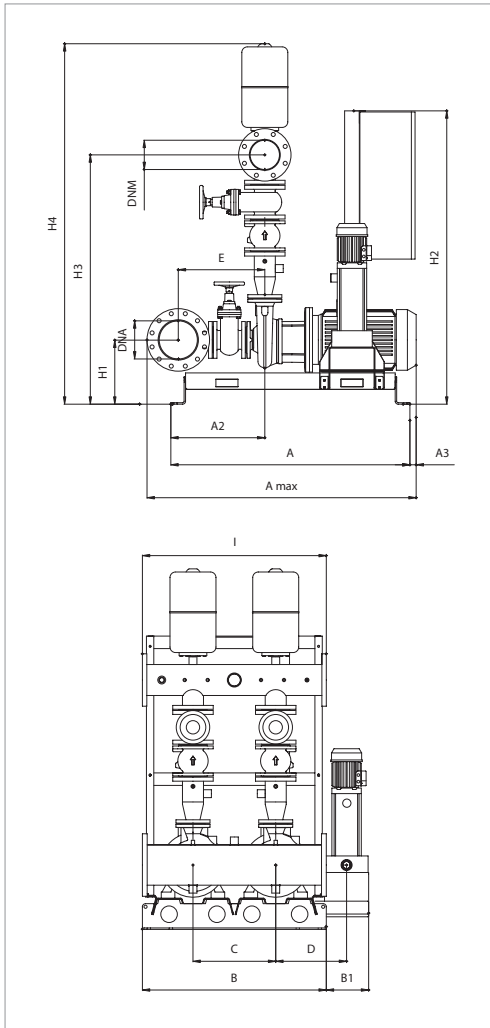

The performance curves are based on kinematic viscosity values = 1 mm²/s and density equivalent to 1000 kg/m³
Curve tolerance according to ISO 9906.
Overall performance taking into account TWO pumps working at the same time.

MODEL	POWER INPUT 50 Hz	P2 NOMINAL		RATED P2 JOCKEY	In A	FLOW m ³ /h	MAX OBTAINABLE PRESSURE BAR	STANDARD PRESSURE BAR
		KW	HP	KW				
2NKP-G 80-160/153 + KVCX 65/80	3x400 V	2 x 15	2 x 20	2,2	2 x 27,5	40 - 440	2,8	2,5
2NKP-G 80-160/163 + KVCX 65/80	3x400 V	2 x 18,5	2 x 25	2,2	2 x 33,5	40 - 480	3,3	3
2NKP-G 80-160/169 + KVCX 65/80	3x400 V	2 x 22	2 x 30	2,2	2 x 39,5	40 - 480	3,7	3,3
2NKP-G 80-200/190 + KVCX 65/80	3x400 V	2 x 30	2 x 40	2,2	2 x 52,5	40 - 480	4,6	4,5

MODEL	A max	A	A2	A3	B	B1*	C	D*	E	I	H1	H2	H3	H4	DNA	DNM
2NKP-G 80-160/153 + KVCX 65/80	1580	1290	445	-	1000	230	450	385	532	1000	350	1600	1460	2090	DN250	DN200
2NKP-G 80-160/163 + KVCX 65/80	1580	1290	445	-	1000	230	450	385	532	1000	350	1600	1460	2090	DN250	DN200
2NKP-G 80-160/169 + KVCX 65/80	1560	1290	511	45	1000	230	450	385	532	1000	350	1600	1460	2090	DN250	DN200
2NKP-G 80-200/190 + KVCX 65/80	1650	1290	434	60	1000	230	450	385	532	1000	370	1600	1505	2135	DN250	DN200

* The sizes are for the set with jockey pump. For the sizes of the set without jockey pump, disregard B1, D, and G.
For the weights contact our sales network.

3 NKP-G 32 - RESIDENTIAL/INDUSTRIAL PRESSURE BOOSTER SETS

Pumped liquid temperature range: from -15 °C to +70 °C - Jockey pump pumped liquid temperature range: from +0 °C to +40 °C.
 Maximum ambient temperature: +40 °C

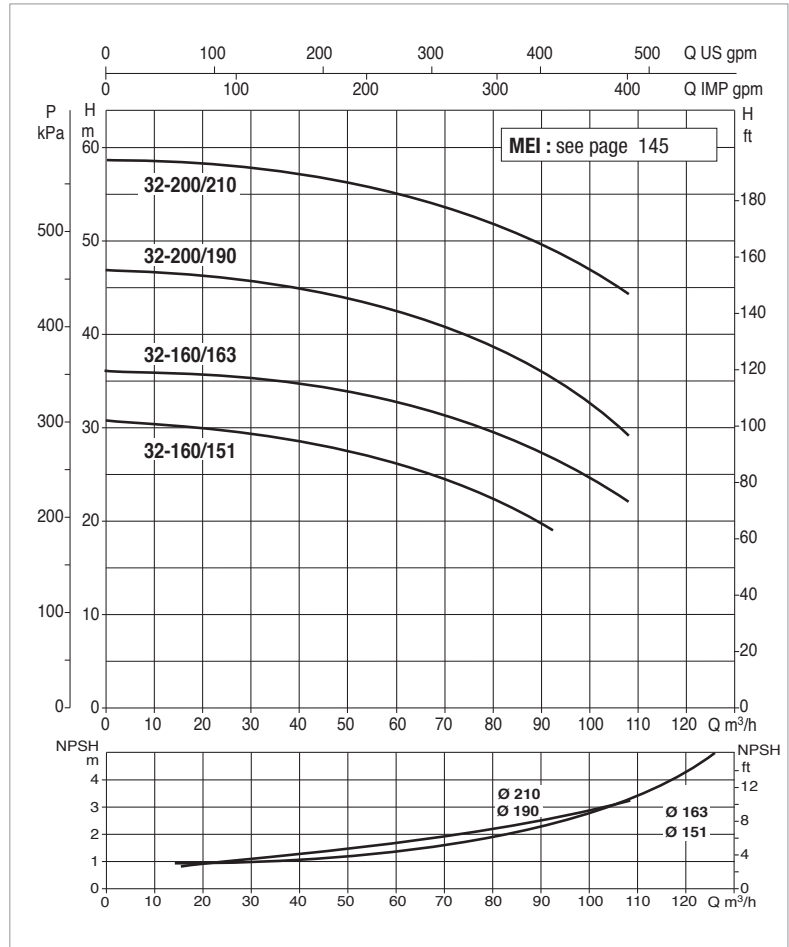
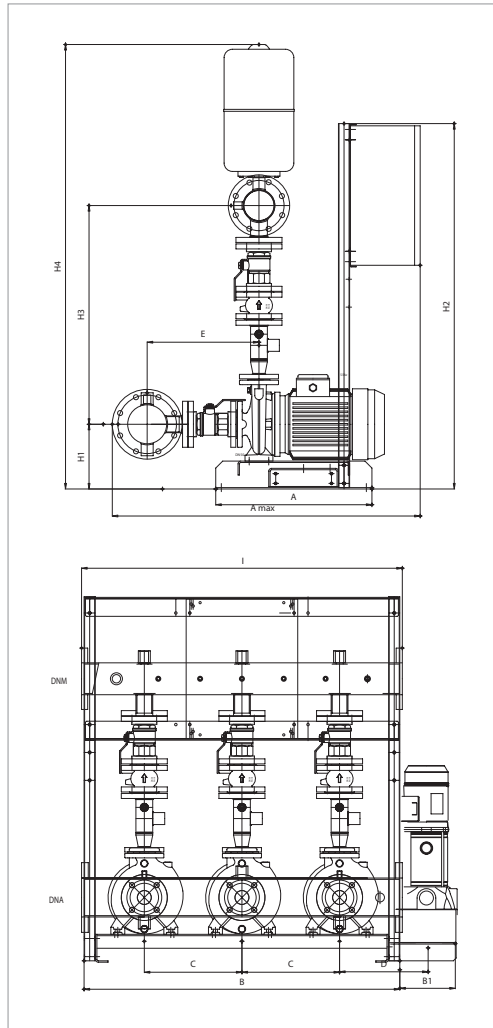

The performance curves are based on kinematic viscosity values = 1 mm²/s and density equivalent to 1000 kg/m³
 Curve tolerance according to ISO 9906.
Overall performance taking into account THREE pumps working at the same time.

MODEL	POWER INPUT 50 Hz	P2 NOMINAL		RATED P2 JOCKEY	In A	FLOW m ³ /h	MAX OBTAINABLE PRESSURE BAR	STANDARD PRESSURE BAR
		KW	HP	KW				
3NKP-G 32-160/151 + KVCX 65/50	3x400 V	3x3	3x4	1,1	3x6,7	4-84	3	2,5
3NKP-G 32-160/163 + KVCX 65/50	3x400 V	3x4	3x5,5	1,1	3x8,7	4-96	3,5	3
3NKP-G 32-200/190 + KVCX 65/50	3x400 V	3x5,5	3x7,5	1,1	3x11,6	4-96	4,5	4
3NKP-G 32-200/210 + KVCX 65/50	3x400 V	3x7,5	3x10	1,1	3x14	4-96	5,6	5

MODEL	A	A max	B	B1*	C	D*	E	H1	H2	H3	H4	I	DNA	DNM
3NKP-G 32-160/151 + KVCX 65/50	560	1104	1132	199	350	318	401	232	1310	784	1593	1150	DN125	DN100
3NKP-G 32-160/163 + KVCX 65/50	560	1104	1132	199	350	318	401	232	1310	784	1593	1150	DN125	DN100
3NKP-G 32-200/190 + KVCX 65/50	560	1104	1132	199	350	318	401	260	1310	804	1641	1150	DN125	DN100
3NKP-G 32-200/210 + KVCX 65/50	560	1104	1132	199	350	318	401	260	1310	804	1641	1150	DN125	DN100

* The sizes are for the set with jockey pump. For the sizes of the set without jockey pump, disregard B1, D, and G.
 For the weights contact our sales network.

3 NKP-G 40 - RESIDENTIAL/INDUSTRIAL PRESSURE BOOSTER SETS

Pumped liquid temperature range: from -15 °C to +70 °C - Jockey pump pumped liquid temperature range: from +0 °C to +40 °C.
Maximum ambient temperature: +40 °C

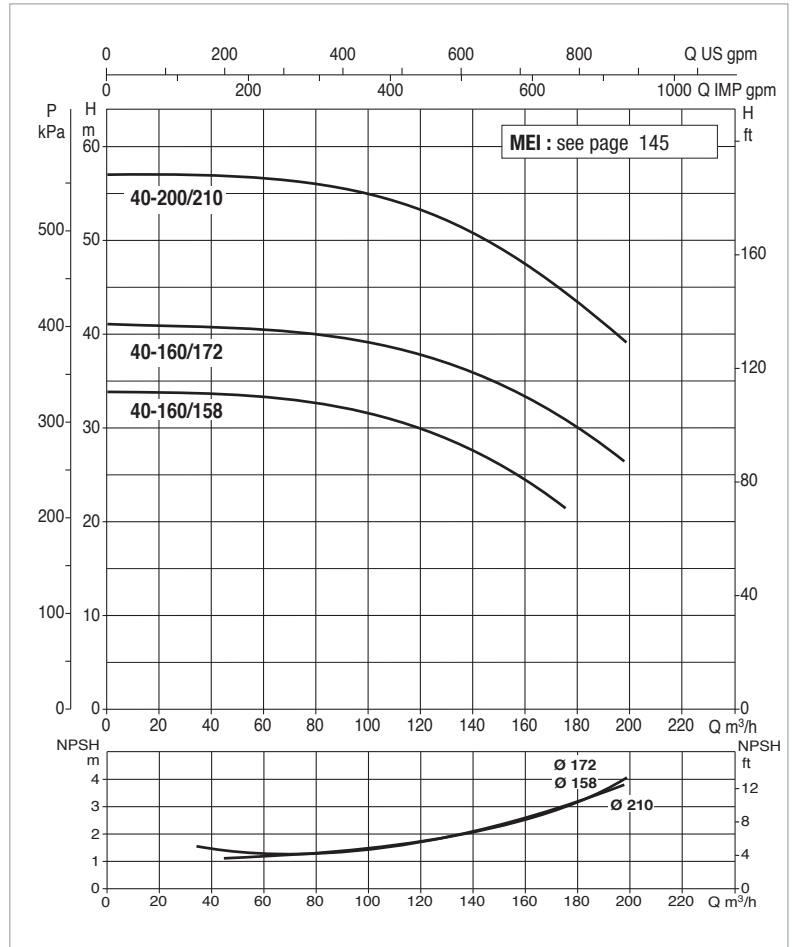
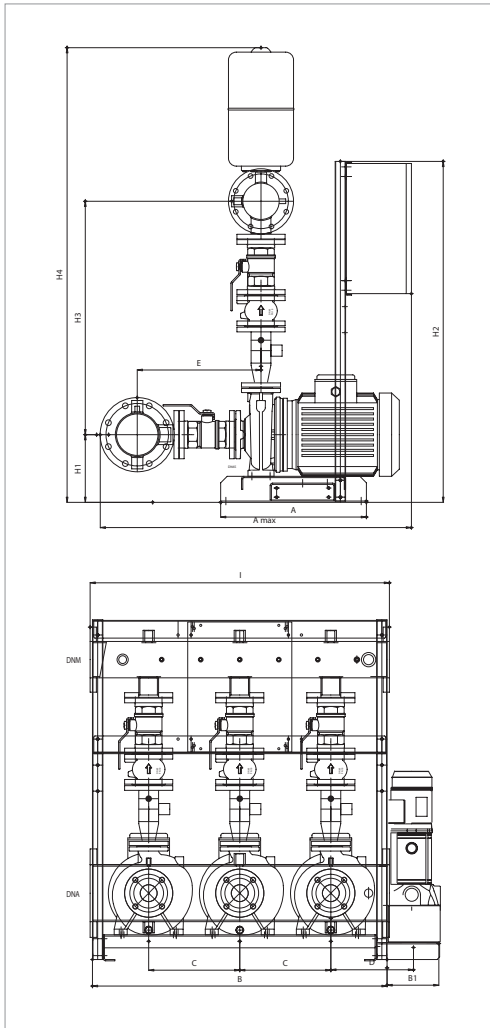

The performance curves are based on kinematic viscosity values = 1 mm²/s and density equivalent to 1000 kg/m³
Curve tolerance according to ISO 9906.
Overall performance taking into account THREE pumps working at the same time.

MODEL	POWER INPUT 50 Hz	P2 NOMINAL		RATED P2 JOCKEY	In A	FLOW m ³ /h	MAX OBTAINABLE PRESSURE BAR	STANDARD PRESSURE BAR
		kW	HP	kW				
3NKP-G 40-160/158 + KVCX 65/50	3x400 V	3 x 5,5	3 x 7,5	1,1	2 x 11,6	10 - 165	3,3	3
3NKP-G 40-160/172 + KVCX 65/50	3x400 V	3 x 7,5	3 x 10	1,1	3 x 14	10 - 180	4	3,5
3NKP-G 40-200/210 + KVCX 65/80	3x400 V	3 x 11	3 x 15	2,2	2 x 22,5	10 - 180	5,5	5

MODEL	A	A max	B	B1*	C	D*	E	H1	H2	H3	H4	I	DNA	DNM
3NKP-G 40-160/158 + KVCX 65/50	560	1176	1132	199	350	318	456	232	1310	877	1699	1150	DN150	DN125
3NKP-G 40-160/172 + KVCX 65/50	560	1176	1132	199	350	318	456	232	1310	877	1699	1150	DN150	DN125
3NKP-G 40-200/210 + KVCX 65/80	560	1176	1132	199	350	318	456	260	1310	897	1747	1150	DN150	DN125

* The sizes are for the set with jockey pump. For the sizes of the set without jockey pump, disregard B1, D, and G.
For the weights contact our sales network.

3 NKP-G 40 - RESIDENTIAL/INDUSTRIAL PRESSURE BOOSTER SETS

Pumped liquid temperature range: from -15 °C to +70 °C - Jockey pump pumped liquid temperature range: from +0 °C to +40 °C.
Maximum ambient temperature: +40 °C

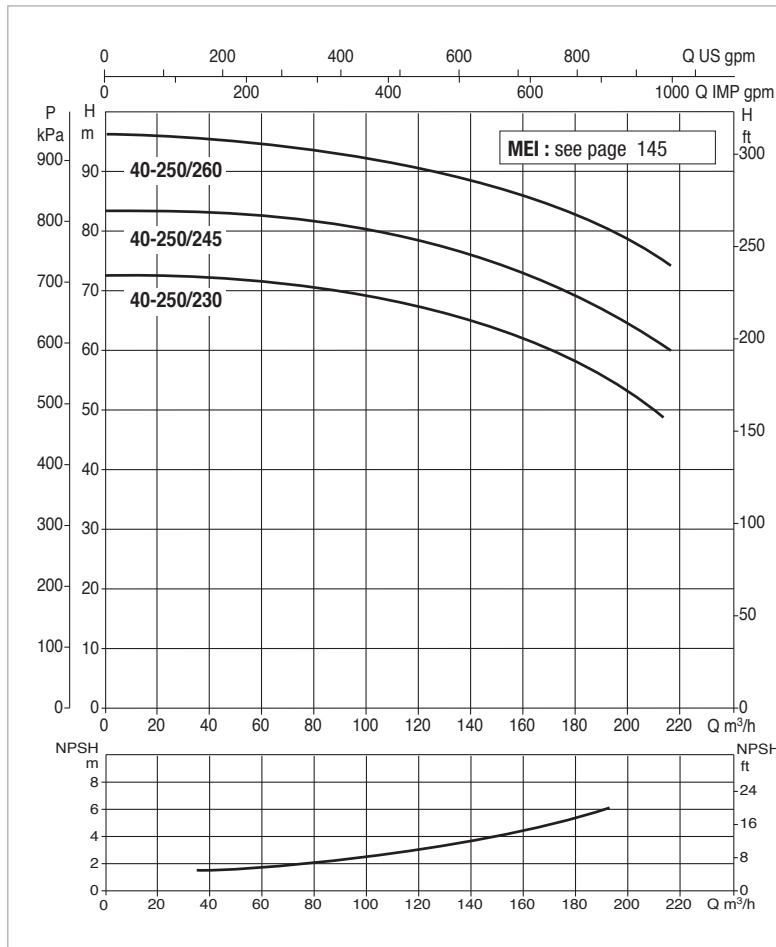
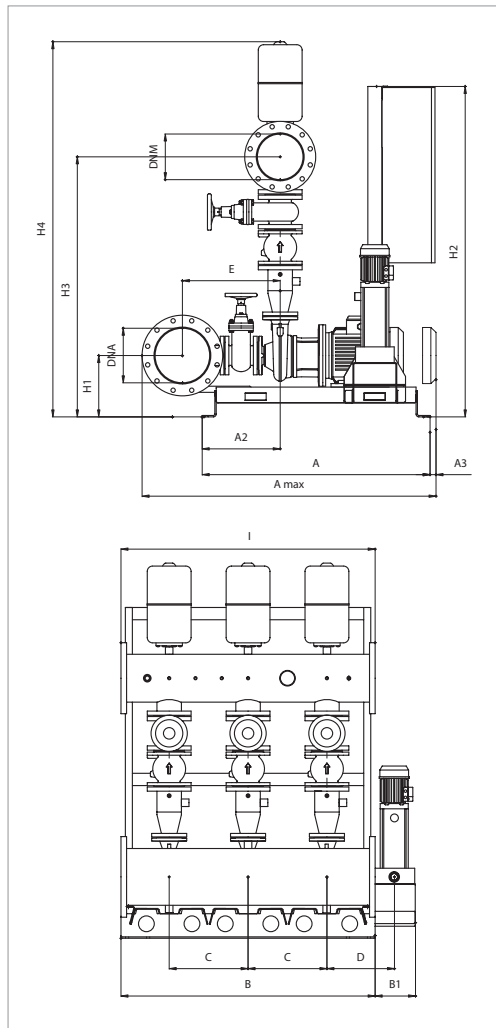

The performance curves are based on kinematic viscosity values = 1 mm²/s and density equivalent to 1000 kg/m³
Curve tolerance according to ISO 9906.
Overall performance taking into account THREE pumps working at the same time.

MODEL	POWER INPUT 50 Hz	P2 NOMINAL		RATED P2 JOCKEY	In A	FLOW m ³ /h	MAX OBTAINABLE PRESSURE BAR	STANDARD PRESSURE BAR
		kW	HP	kW				
3NKP-G 40-250/230 + KVCX 65/80	3x400 V	3 x 15	3 x 20	2,2	3 x 31	10 - 210	7	6,5
3NKP-G 40-250/245 + KVCX 65/80	3x400 V	3 x 18,5	3 x 25	2,2	3 x 36	10 - 210	8	7,5
3NKP-G 40-250/260 + KVCX 65/80	3x400 V	3 x 22	3 x 30	2,2	3 x 43	10 - 210	9,3	8,5

MODEL	A max	A	A2	B	B1*	C	D*	E	I	H1	H2	H3	H4	DNA	DNM
3NKP-G 40-250/230 + KVCX 65/80	1435	1290	477	1450	230	450	385	475	1450	350	1600	1295	1855	DN150	DN125
3NKP-G 40-250/245 + KVCX 65/80	1335	1290	579	1450	230	450	385	475	1450	350	1600	1295	1855	DN150	DN125
3NKP-G 40-250/260 + KVCX 65/80	1335	1290	579	1450	230	450	385	475	1450	350	1600	1295	1855	DN150	DN125

* The sizes are for the set with jockey pump. For the sizes of the set without jockey pump, disregard B1, D, and G.
For the weights contact our sales network.

3 NKP-G 50 - RESIDENTIAL/INDUSTRIAL PRESSURE BOOSTER SETS

Pumped liquid temperature range: from -15 °C to +70 °C - Jockey pump pumped liquid temperature range: from +0 °C to +40 °C.
 Maximum ambient temperature: +40 °C

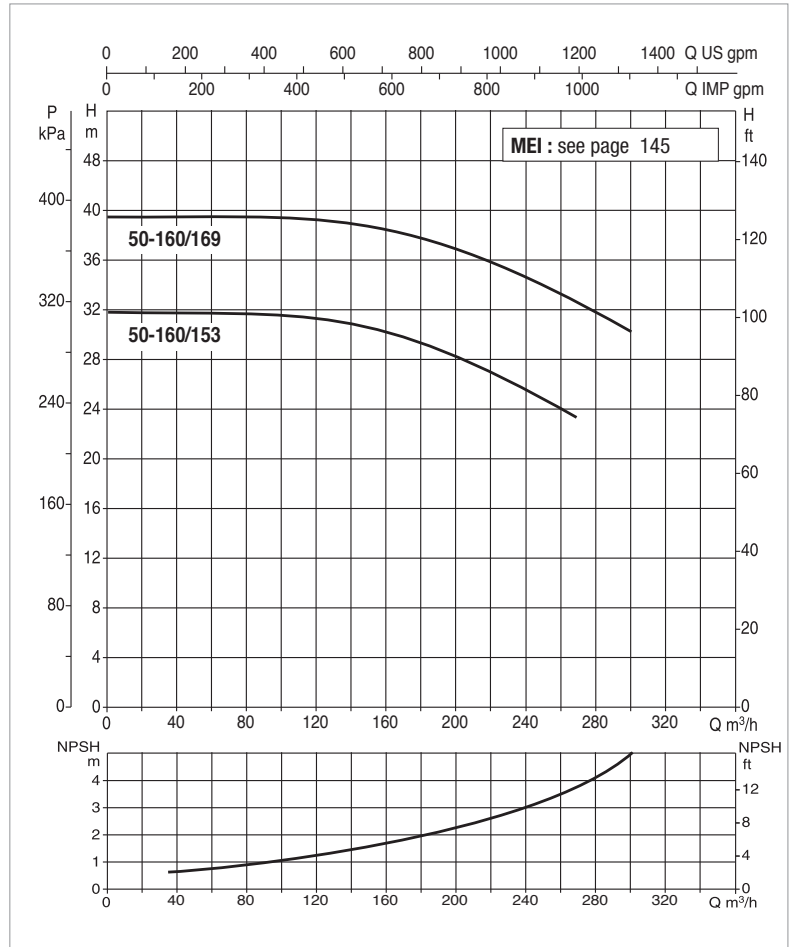
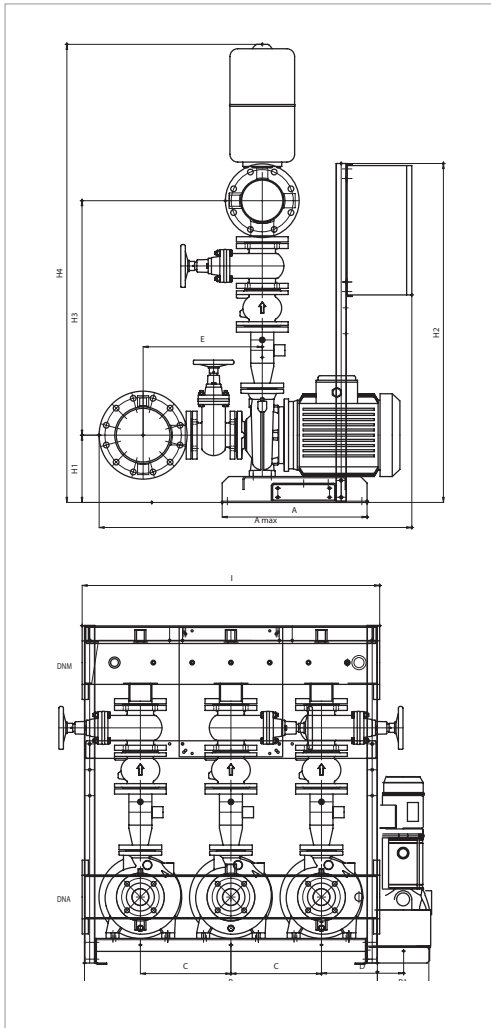

The performance curves are based on kinematic viscosity values = 1 mm²/s and density equivalent to 1000 kg/m³
 Curve tolerance according to ISO 9906.
Overall performance taking into account THREE pumps working at the same time.

MODEL	POWER INPUT 50 Hz	P2 NOMINAL		RATED P2 JOCKEY	In A	FLOW m ³ /h	MAX OBTAINABLE PRESSURE BAR	STANDARD PRESSURE BAR
		kW	HP	kW				
3NKP-G 50-160/153 + KVCX 65/50	3x400 V	3x7,5	3x10	1,1	3x14	10 – 240	3	2,5
3NKP-G 50-160/169 + KVCX 65/80	3x400 V	3x11	3x15	2,2	2x22,5	10 – 270	3,8	3,3

MODEL	A	A max	B	B1*	C	D*	E	H1	H2	H3	H4	I	DNA	DNM
3NKP-G 50-160/153 + KVCX 65/50	560	1209	1132	199	350	318	461	260	1310	906	1770	1150	DN200	DN150
3NKP-G 50-160/169 + KVCX 65/80	560	1209	1132	199	350	318	461	260	1310	906	1770	1150	DN200	DN150

* The sizes are for the set with jockey pump. For the sizes of the set without jockey pump, disregard B1, D, and G.
 For the weights contact our sales network.

3 NKP-G 50 - RESIDENTIAL/INDUSTRIAL PRESSURE BOOSTER SETS

Pumped liquid temperature range: from -15 °C to +70 °C - Jockey pump pumped liquid temperature range: from +0 °C to +40 °C.
Maximum ambient temperature: +40 °C

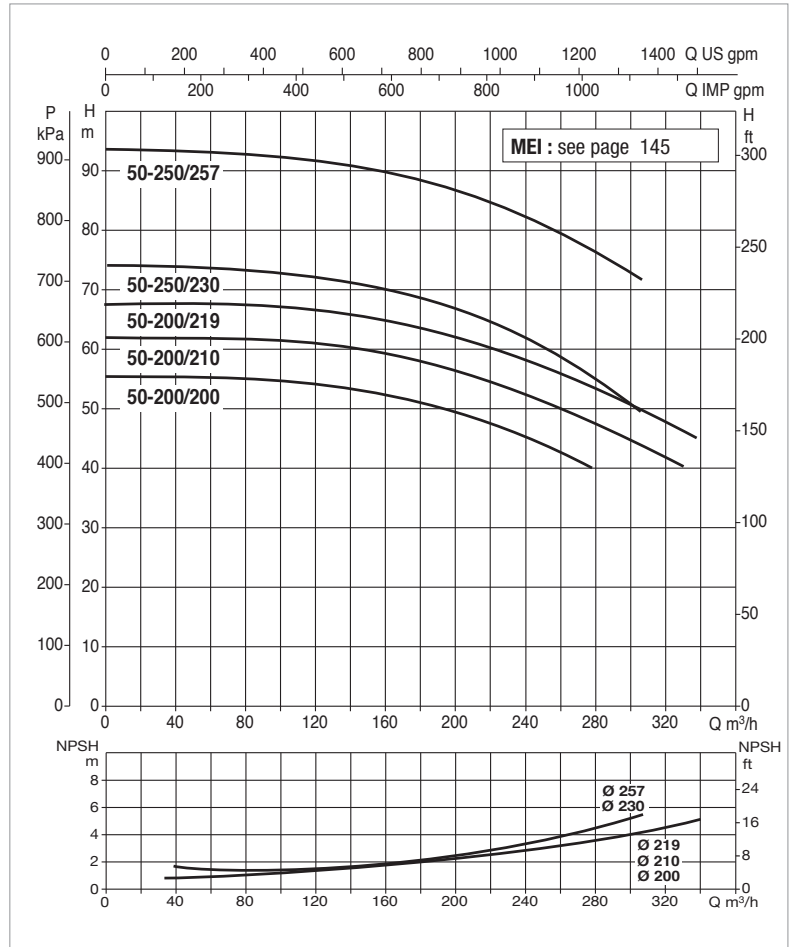
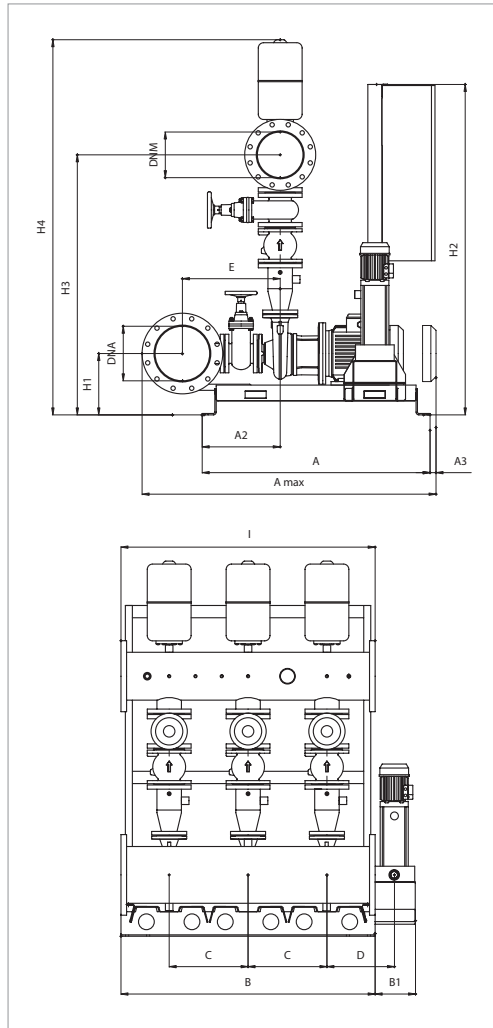

The performance curves are based on kinematic viscosity values = 1 mm²/s and density equivalent to 1000 kg/m³
Curve tolerance according to ISO 9906.
Overall performance taking into account THREE pumps working at the same time.

MODEL	POWER INPUT 50 Hz	P2 NOMINAL		RATED P2 JOCKEY	In A	FLOW m ³ /h	MAX OBTAINABLE PRESSURE BAR	STANDARD PRESSURE BAR
		KW	HP	KW				
3NKP-G 50-200/200 + KVCX 65/80	3x400 V	3 x 15	3 x 20	2,2	2 x 31	10 – 270	5,2	5
3NKP-G 50-200/210 + KVCX 65/80	3x400 V	3 x 18,5	3 x 25	2,2	3 x 36	10 – 330	6	5,5
3NKP-G 50-200/219 + KVCX 65/80	3x400 V	3 x 22	3 x 30	2,2	3 x 43	10 – 330	6,5	6
3NKP-G 50-250/230 + KVCX 65/80	3x400 V	3 x 22	3 x 30	2,2	3 x 43	10 – 300	7	6,5
3NKP-G 50-250/257 + KVCX 65/80	3x400 V	3 x 30	3 x 40	2,2	2 x 57	10 – 300	9	8,5

MODEL	A max	A	A2	B	B1*	C	D*	E	I	H1	H2	H3	H4	DNA	DNM
3NKP-G 50-200/200 + KVCX 65/80	1495	1290	434	1450	230	450	385	460	1450	330	1600	1260	1865	DN200	DN150
3NKP-G 50-200/210 + KVCX 65/80	1345	1290	579	1450	230	450	385	460	1450	330	1600	1260	1865	DN200	DN150
3NKP-G 50-200/219 + KVCX 65/80	1345	1290	579	1450	230	450	385	460	1450	330	1600	1260	1865	DN200	DN150
3NKP-G 50-250/230 + KVCX 65/80	1345	1290	579	1450	230	450	385	460	1450	350	1600	1305	1910	DN200	DN150
3NKP-G 50-250/257 + KVCX 65/80	1345	1290	579	1450	230	450	385	460	1450	350	1600	1305	1910	DN200	DN150

* The sizes are for the set with jockey pump. For the sizes of the set without jockey pump, disregard B1, D, and G.
For the weights contact our sales network.

3 NKP-G 65 - RESIDENTIAL/INDUSTRIAL PRESSURE BOOSTER SETS

Pumped liquid temperature range: from -15 °C to +70 °C - Jockey pump pumped liquid temperature range: from +0 °C to +40 °C.
Maximum ambient temperature: +40 °C

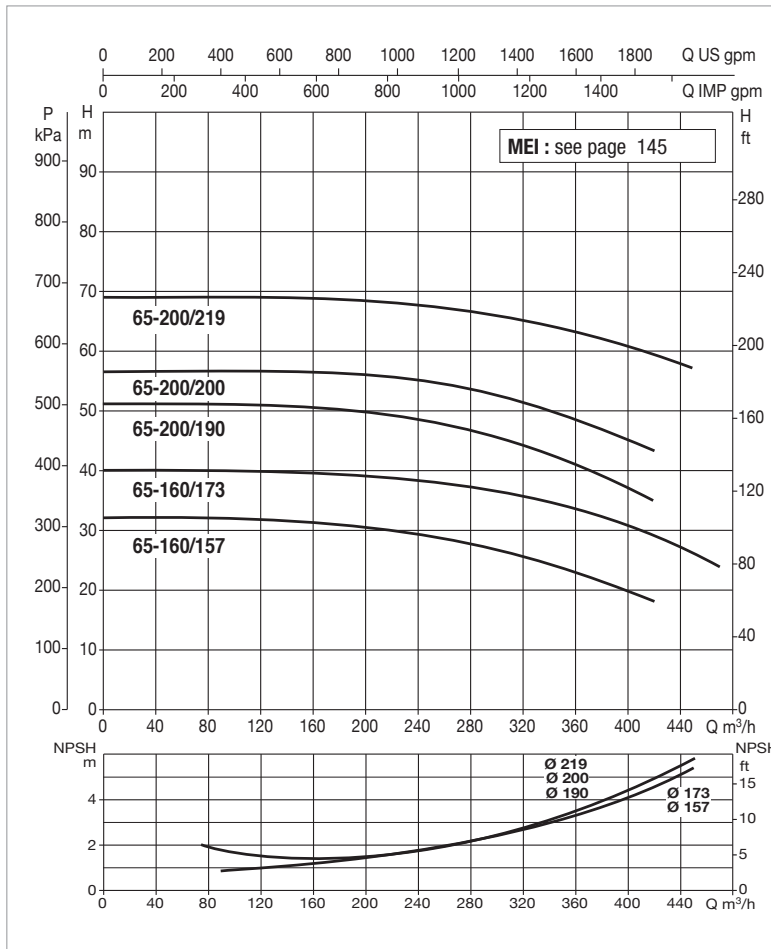
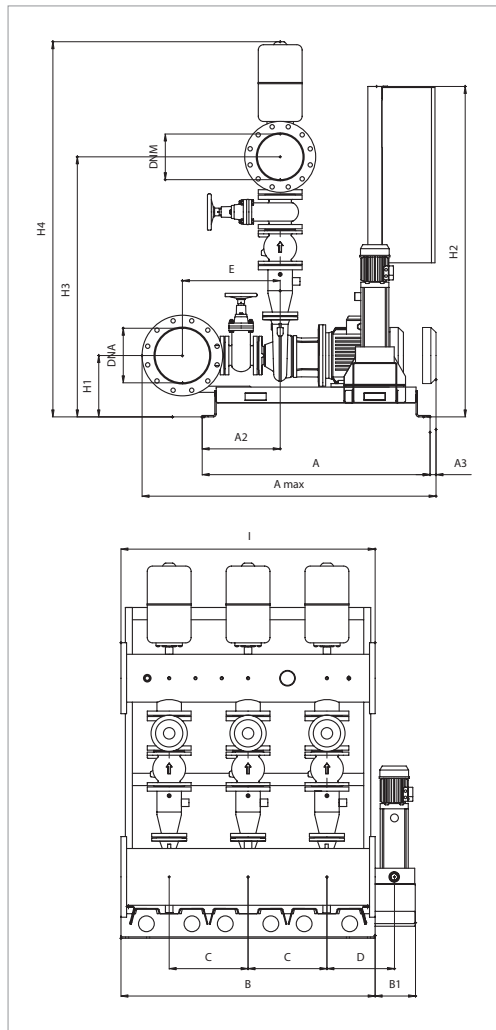

The performance curves are based on kinematic viscosity values = 1 mm²/s and density equivalent to 1000 kg/m³
Curve tolerance according to ISO 9906.
Overall performance taking into account THREE pumps working at the same time.

MODEL	POWER INPUT 50 Hz	P2 NOMINAL		RATED P2 JOCKEY	In A	FLOW m ³ /h	MAX OBTAINABLE PRESSURE BAR	STANDARD PRESSURE BAR
		KW	HP	KW				
3NKP-G 65-160/157 + KVCX 65/80	3x400 V	3x11	3x15	2,2	3x20,4	20 - 420	3	2,5
3NKP-G 65-160/173 + KVCX 65/80	3x400 V	3x15	3x20	2,2	3x27,5	20 - 450	3,8	3,5
3NKP-G 65-200/190 + KVCX 65/80	3x400 V	3x18,5	3x25	2,2	3x33,5	20 - 420	5	4,5
3NKP-G 65-200/200 + KVCX 65/80	3x400 V	3x22	3x30	2,2	3x39,5	20 - 420	5,5	5
3NKP-G 65-200/219 + KVCX 65/80	3x400 V	3x30	3x40	2,2	3x52,5	20 - 420	6,5	6

MODEL	A max	A	A2	A3	B	B1*	C	D*	E	I	H1	H2	H3	H4	DNA	DNM
3NKP-G 65-160/157 + KVCX 65/80	1550	1290	445	-	1450	230	450	385	500	1450	350	1600	1365	2000	DN250	DN200
3NKP-G 65-160/173 + KVCX 65/80	1550	1290	445	-	1450	230	450	385	500	1450	350	1600	1365	2000	DN250	DN200
3NKP-G 65-200/190 + KVCX 65/80	1550	1290	445	-	1450	230	450	385	500	1450	350	1600	1390	2005	DN250	DN200
3NKP-G 65-200/200 + KVCX 65/80	1525	1290	511	45	1450	230	450	385	500	1450	350	1600	1390	2005	DN250	DN200
3NKP-G 65-200/219 + KVCX 65/80	1590	1290	464	60	1450	230	450	385	500	1450	370	1600	1410	2045	DN250	DN200

* The sizes are for the set with jockey pump. For the sizes of the set without jockey pump, disregard B1, D, and G.
For the weights contact our sales network.

3 NKP-G 80 - RESIDENTIAL/INDUSTRIAL PRESSURE BOOSTER SETS

Pumped liquid temperature range: from -15 °C to +70 °C - Jockey pump pumped liquid temperature range: from +0 °C to +40 °C.
Maximum ambient temperature: +40 °C

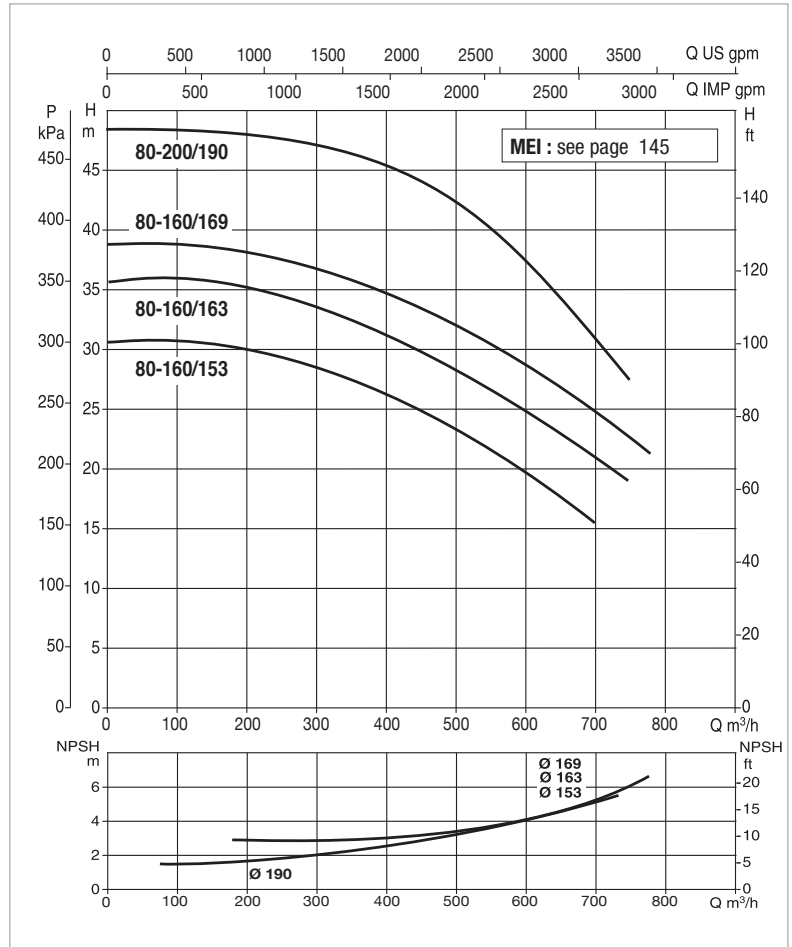
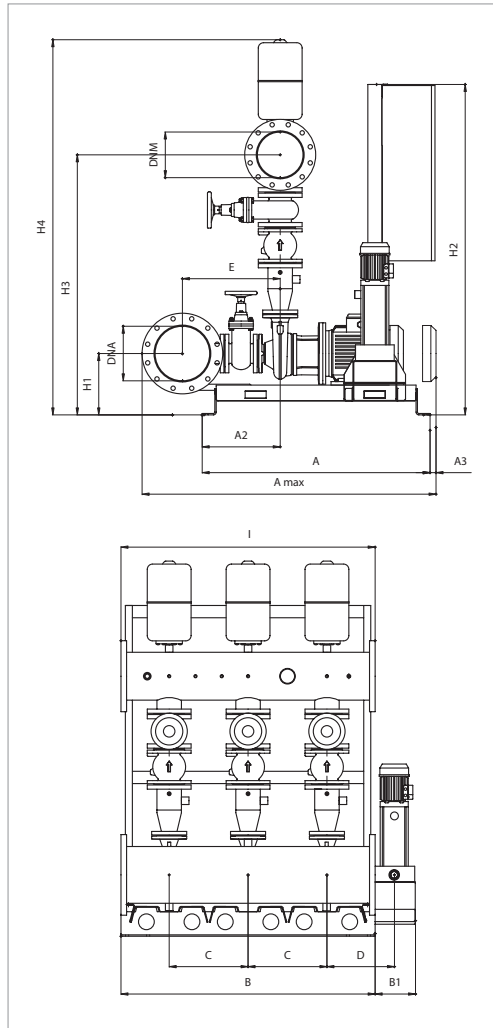

The performance curves are based on kinematic viscosity values = 1 mm²/s and density equivalent to 1000 kg/m³
Curve tolerance according to ISO 9906.
Overall performance taking into account THREE pumps working at the same time.

MODEL	POWER INPUT 50 Hz	P2 NOMINAL		RATED P2 JOCKEY	In A	FLOW m ³ /h	MAX OBTAINABLE PRESSURE BAR	STANDARD PRESSURE BAR
		KW	HP	KW				
3NKP-G 80-160/153 + KVCX 65/80	3x400 V	3 x 15	3 x 20	2,2	3 x 27,5	40 - 660	2,8	2,5
3NKP-G 80-160/163 + KVCX 65/80	3x400 V	3 x 18,5	3 x 25	2,2	3 x 33,5	40 - 720	3,3	3
3NKP-G 80-160/169 + KVCX 65/80	3x400 V	3 x 22	3 x 30	2,2	3 x 39,5	40 - 720	3,7	3,3
3NKP-G 80-200/190 + KVCX 65/80	3x400 V	3 x 30	3 x 40	2,2	3 x 52,5	40 - 720	4,6	4,5

MODEL	A max	A	A2	A3	B	B1*	C	D*	E	I	H1	H2	H3	H4	DNA	DNM
3NKP-G 80-160/153 + KVCX 65/80	1635	1290	445	-	1450	230	450	385	560	1450	350	1600	1490	2145	DN300	DN250
3NKP-G 80-160/163 + KVCX 65/80	1635	1290	445	-	1450	230	450	385	560	1450	350	1600	1490	2145	DN300	DN250
2NKP-G 80-160/169 + KVCX 65/80	1615	1290	511	45	1450	230	450	385	560	1450	350	1600	1490	2145	DN300	DN250
3NKP-G 80-200/190 + KVCX 65/80	1705	1290	434	60	1450	230	450	385	560	1450	370	1600	1535	2190	DN300	DN250

* The sizes are for the set with jockey pump. For the sizes of the set without jockey pump, disregard B1, D, and G.
For the weights contact our sales network.

HYDRAULIC EFFICIENCY

EU 547/2012 REGULATION - MEI

GENERAL INFORMATION

The MEI index (Minimum Efficiency Index) was issued with the objective of defining a performance threshold value applicable to all the water pumps found on the market. The MEI index takes into account the size of the pump, its specific speed, and its speed of rotation.

The regulation applies to centrifugal pumps used for pumping clean waters included in the following categories:

- Axial suction pumps with support (ESOB).
- Horizontal monobloc axial suction pumps (ESCC).
- In-line monobloc axial suction pumps (ESCCI).
- Multistage vertical pumps (MS-V).
- Multistage submerged pumps (MSS).

MEI is a dimensionless indicator for hydraulic performance, and a measure of the quality of the sizing of the pump in relation to the performance.

The higher the MEI value, the better is the sizing of the pump in relation to the performance, and the lower is the annual energy consumption due to the use of the pump. In theory, the upper limit of the MEI values is open, and only depends on physical and technological limitations.

The minimum efficiency index (MEI) is based on the maximum diameter of the impeller. Multistage vertical water pumps must be tested in the 3-stage version.

The value of reference for the more efficient water pumps is $MEI \geq 0,70$.

The efficiency of a pump with turned impeller is generally lower to that of a pump with full impeller diameter. The turning of the impeller adapts the pump to a fixed point of operation, resulting in lower energy consumption.

The operation of this water pump with variable operating points can be more efficient and economical if controlled, for example, by means of a variable speed motor adapting the operation of the pump to the system.

The information on the efficiency of reference can be found at the address: www.dabpumps.com. In alternative contact your local sales representatives.

The $MEI=0,7$ and $MEI=0,4$ efficiency charts for the different types of pumps can be found at the website: www.europump.org/efficiencycharts.

PUMP MODEL	IMPELLER	MEI
NKP-G 32-160/177 T 5,5 *	Full	$\geq 0,40$
NKP-G 32-160/151 T 3	Turned	
NKP-G 32-160/163 T 4	Turned	
NKP-G 32-200/210 T 7,5	Full	$\geq 0,50$
NKP-G 32-200/190 T 5,5	Turned	
NKP-G 40-160/172 T 7,5	Full	$\geq 0,50$
NKP-G 40-160/158 T 5,5	Turned	
NKP-G 40-200/210 T 11	Full	$\geq 0,40$
NKP-G 40-250/260 T 22	Full	$\geq 0,50$
NKP-G 40-250/230 T 15	Turned	
NKP-G 40-250/245 T 18,5	Turned	
NKP-G 50-160/169 T 11	Full	$\geq 0,40$
NKP-G 50-160/153 T 7,5	Turned	
NKP-G 50-200/219 T 22	Full	$\geq 0,50$
NKP-G 50-200/200 T 15	Turned	
NKP-G 50-200/210 T 18,5	Turned	
NKP-G 50-250/257 T 30	Full	$\geq 0,40$
NKP-G 50-250/230 T 22	Turned	
NKP-G 65-160/173 T 15	Full	$\geq 0,50$
NKP-G 65-160/157 T 11	Turned	
NKP-G 65-200/219 T 30	Full	$\geq 0,70$
NKP-G 65-200/190 T 18,5	Turned	
NKP-G 65-200/200 T 22	Turned	

* Model used for MEI reference only.

The MEI values for electronic pumps refer to the same pump without electronic unit.

PUMP MODEL	IMPELLER	MEI
NKP-G 80-160/169 T 22	Full	$\geq 0,40$
NKP-G 80-160/153 T 15	Turned	
NKP-G 80-160/163 T 18,5	Turned	
NKP-G 80-200/190 T 30	Full	$\geq 0,40$

The MEI values for electronic pumps refer to the same pump without electronic unit.

HYDRAULIC EFFICIENCY

EU 547/2012 REGULATION - MEI

PUMP MODEL	NUMBER OF STAGES	MEI	η_{PL}	η_{BEP}	η_{OL}	
KVC 30/50 M	3	$\geq 0,60$	40,75	43,10	42,76	
KVC 30/50 T			40,19	43,10	42,60	
KVC 40/50 M	4		40,73	43,34	42,91	
KVC 40/50 T			38,85	41,40	40,92	
KVC 55/50 M	5		38,90	41,70	41,20	
KVC 55/50 T			38,97	41,61	41,15	
KVC 65/50 M	6		37,53	39,21	38,75	
KVC 65/50 T			36,52	40,13	39,42	
KVC 75/50 M	7		36,39	38,91	38,35	
KVC 75/50 T			36,51	39,61	39,05	
KVC 30/80 M	4		$\geq 0,40$	44,06	46,30	45,84
KVC 30/80 T				42,16	45,10	44,44
KVC 40/80 M	5	43,43		46,97	46,80	
KVC 40/80 T		41,94		44,40	43,89	
KVC 45/80 M	6	41,91		43,96	43,57	
KVC 45/80 T		41,06		43,74	43,31	
KVC 55/80 M	7	41,05		43,00	42,63	
KVC 55/80 T		40,75		43,51	43,05	
KVC 65/80 T	8	41,08		44,02	43,48	
KVC 35/120 M	3	$\geq 0,50$		49,31	51,00	50,76
KVC 35/120 T				49,83	51,80	51,38
KVC 45/120 M	4			47,59	49,50	48,96
KVC 45/120 T			47,47	49,30	49,00	
KVC 60/120 T	5		47,81	49,44	48,97	
KVC 70/120 T	6		47,58	49,00	48,61	
KVC 85/120 T	7		49,23	50,84	50,20	

The MEI values for electronic pumps refer to the same pump without electronic unit.

HYDRAULIC EFFICIENCY

EU 547/2012 REGULATION - MEI

PUMP MODEL	NUMBER OF STAGES	MEI	η_{PL}	η_{BEP}	η_{OL}	
KV 3/10 M	10	$\geq 0,40$	47,83	52,40	51,69	
KV 3/10 T			48,71	52,30	51,44	
KV 3/12 M	12		49,22	53,67	52,94	
KV 3/12 T			45,09	48,45	47,97	
KV 3/15 T	15		47,81	52,55	51,54	
KV 3/18 T	18		48,11	41,91	51,17	
KV 6/7 M	7		$\geq 0,40$	50,28	54,00	53,47
KV 6/7 T				50,66	54,57	53,74
KV 6/9 M	9			50,52	55,10	54,34
KV 6/9 T				45,85	49,42	49,11
KV 6/11 M	11	49,10		52,67	52,16	
KV 6/11 T		48,37		51,58	51,06	
KV 6/15 T	15	51,09		55,20	54,44	
KV 10/4 M	4	$\geq 0,40$		53,89	55,88	55,60
KV 10/4 T				53,72	57,24	56,93
KV 10/5 M	5			54,72	57,27	56,81
KV 10/5 T			54,92	57,35	56,73	
KV 10/6 M	6		57,77	60,20	59,48	
KV 10/6 T			57,97	60,30	59,88	
KV 10/8 T	8		57,41	60,77	60,59	

The MEI values for electronic pumps refer to the same pump without electronic unit.

PUMP MODEL	NUMBER OF STAGES	MEI	η_{PL}	η_{BEP}	η_{OL}
NKV 10/5	5	$\geq 0,60$	65,48	69,58	68,81
NKV 10/6	6		66,55	68,40	67,76
NKV 10/7	7		66,11	68,52	67,86
NKV 10/8	8		64,66	67,13	66,08
NKV 10/9	9		66,77	68,94	68,26
NKV 10/10	10		66,44	69,13	68,43
NKV 10/12	12		65,97	68,88	67,71
NKV 10/14	14		63,80	66,29	65,51

The MEI values for electronic pumps refer to the same pump without electronic unit.

PUMP MODEL	NUMBER OF STAGES	MEI	η_{PL}	η_{BEP}	η_{OL}
NKV 15/3	3	$\geq 0,60$	68,74	72,03	71,26
NKV 15/4	4		70,15	72,54	71,91
NKV 15/5	5		70,40	74,23	73,48
NKV 15/6	6		70,19	73,29	72,46
NKV 15/7	7		69,81	73,65	72,91
NKV 15/8	8		68,06	71,49	70,86
NKV 15/9	9		69,77	73,07	72,30
NKV 15/10	10		66,95	70,35	69,67

The MEI values for electronic pumps refer to the same pump without electronic unit.

HYDRAULIC EFFICIENCY

EU 547/2012 REGULATION - MEI

PUMP MODEL	NUMBER OF STAGES	MEI	η_{PL}	η_{BEP}	η_{OL}
NKV 20/3	3	$\geq 0,60$	70,47	71,40	70,59
NKV 20/4	4		66,24	69,74	69,33
NKV 20/5	5		72,31	74,50	73,90
NKV 20/6	6		70,37	73,40	72,90
NKV 20/7	7		70,13	74,04	73,38
NKV 20/8	8		69,63	72,06	71,60
NKV 20/9	9		71,68	74,41	73,68
NKV 20/10	10		70,44	73,42	72,96

The MEI values for electronic pumps refer to the same pump without electronic unit.

PUMP MODEL	NUMBER OF STAGES	MEI	η_{PL}	η_{BEP}	η_{OL}
NKV 32/3	3	$\geq 0,70$	70,08	74,12	73,16
NKV 32/2-2	2		65,89	69,98	69,26
NKV 32/2	2		70,08	74,12	73,16
NKV 32/3-2	3		67,38	71,10	70,20
NKV 32/4-2	4		68,05	71,78	70,92
NKV 32/4	4		70,08	74,12	73,16
NKV 32/5-2	5		68,40	72,20	71,44
NKV 32/5	5		70,08	74,12	73,16
NKV 32/6-2	6		68,62	72,49	71,81
NKV 32/6	6		70,08	74,12	73,16

The MEI values for electronic pumps refer to the same pump without electronic unit.

PUMP MODEL	NUMBER OF STAGES	MEI	η_{PL}	η_{BEP}	η_{OL}
NKV 45/3	3	$\geq 0,70$	73,47	76,37	75,25
NKV 45/2-2	2		69,13	71,65	70,46
NKV 45/2	2		73,47	76,37	75,25
NKV 45/3-2	3		69,79	73,42	72,55
NKV 45/4-2	4		70,11	74,21	73,56
NKV 45/4	4		73,47	76,37	75,25
NKV 45/5-2	5		70,36	74,67	74,14
NKV 45/5	5		73,47	76,37	75,25
NKV 45/6-2	6		70,50	74,96	74,52
NKV 45/6	6		73,47	76,37	75,25

The MEI values for electronic pumps refer to the same pump without electronic unit.

ACCESSORIES

ACCESSORIES

PRESSURE SETS

	MODEL
	1" ½ MF FLEXIBLE HOSE
	2" ½ MF 10B FLEXIBLE HOSE
	THREADED ANTI-VIBRATION COUPLING FF 2" - PN 16
	THREADED ANTI-VIBRATION COUPLING FF 2" ½ - PN 16
	MF 1" BALL VALVE (VESSEL MAINTENANCE)
	DRY RUN PROTECTION PRESSURE SWITCH.
	MINIMUM PRESSURE PRESSURE SWITCH KIT (DRY RUN)
	MAXIMUM PRESSURE PRESSURE SWITCH KIT (OVERPRESSURE)

ACCESSORIES

PRESSURE SETS

	MODEL
	PROTECTION FLOAT AGAINST DRY RUN - 5 METRES
	PROTECTION FLOAT AGAINST DRY RUN - 10 METRES
	1" AIR SUPPLY COUPLING KIT
	1" ¼ AIR SUPPLY COUPLING KIT
	1" ½ AIR SUPPLY COUPLING KIT
	G 8 LITRE 10 BAR V TANK
	G 18 LITRE 10 BAR V TANK
	G 18 LITRE 16 BAR V TANK
	SZ 3 (3 KVC AND 3 KVCX) EXCHANGE MODULE
	PRESSURE TRANSMITTER 16 BAR (2-PUMP SETS WITH E-BOX CONTROL PANEL)

ACCESSORIES

PRESSURE BOOSTER SETS WITH 1 - 2 - 3 NKP-G / K SERIES CENTRIFUGAL PUMPS

	MODEL
 <p>FF 21/2 PN 16 Anti-vibration couplings</p>	FF 21/2 PN 16 ANTI-VIBRATION COUPLINGS
	DN 80 PN 16 ANTI-VIBRATION COUPLING
	DN 100 PN 16 ANTI-VIBRATION COUPLING
	DN 125 PN 16 ANTI-VIBRATION COUPLING
	DN 150 PN 16 ANTI-VIBRATION COUPLING
	DN 200 PN 16 ANTI-VIBRATION COUPLING
	DN 250 PN 16 ANTI-VIBRATION COUPLING
	DN 300 PN 16 ANTI-VIBRATION COUPLING
	MINIMUM PRESSURE PRESSURE SWITCH (DRY RUN)
 <p>DN 80 Bottom valve with filter</p>	DN 80 BOTTOM VALVE WITH FILTER
	DN 100 BOTTOM VALVE WITH FILTER
	DN 125 BOTTOM VALVE WITH FILTER
	DN 150 BOTTOM VALVE WITH FILTER
	DN 200 BOTTOM VALVE WITH FILTER
	DN 250 BOTTOM VALVE WITH FILTER
	DN 300 BOTTOM VALVE WITH FILTER

TECHNICAL APPENDIX

GENERAL INFORMATION

FUNDAMENTAL TERMS USED IN PUMPS

The following is a list of fundamental terms used in pumps and an explanation of their meanings. Their knowledge is necessary in order to discuss hydraulic pumps. All measurements are given in Technical units. Reference should be made to the chart for their international and Anglo-Saxon equivalents.

HEAD

Head means height, difference in level, gradient. For example if a pump has a flow of Q litres per second and a head of 30 metres, it means that it is capable of raising Q litres of liquid by 30 metres every second (therefore achieving a 30 metre gradient). For each given pump, the head is determined by its construction, such as the external diameter of the impeller and the speed of rotation, but it is not affected by the pumped liquid. This means that the pump as such can raise by 30 metres Q litres per second of water, petrol, mercury, etc.; the only difference in the three cases will be the power of the motor required.

SPECIFIC WEIGHT OF A LIQUID OR FLUID

The specific weight of a liquid or fluid is the weight per unit volume of the liquid/fluid. Specific weight is usually measured in kg/dm³ or kg/l, remembering that 1 dm³ equals 1 litre.

PRESSURE

Pressure means weight per unit of area (e.g. kg/cm²), and it should not be confused with head. In the case of liquids, the pressure that the liquid exerts on a surface is given by the product of the head (or height) of the liquid, multiplied by its specific weight. For this reason, the column of several km of air on the earth's surface produces at sea level a pressure of about 1kg/cm² (equal to approx. 1 atmosphere). If the same column were of water rather than air, the pressure would be some 700 to 800 times greater, due to the fact that water has a specific weight approximately 700-800 times greater than that of air.

Bearing in mind that a column of water 10 m high is equivalent to approx. 1 kg/cm², if we placed a manometer on the delivery of the pump, the following pressure increases would be measured:

- | | |
|--|---|
| a) with petrol (specific weight 0,7 kg/dm ³) | = 00,7 x 0,001 x 30 x 100 = 2,1 kg/cm ² |
| b) with water (specific weight 1,0 kg/dm ³) | = 00,1 x 0,001 x 30 x 100 = 3,0 kg/cm ² |
| c) with mercury (specific weight 13,6 kg/dm ³) | = 13,6 x 0,001 x 30 x 100 = 40,8 kg/cm ² |

FLOW

Flow means the quantity of liquid or fluid that passes through a point, such as the delivery outlet of a pump, or a cross section of a pipe, in the set unit of time.

This can be measured in litres per minute (l/min), litres per second (l/s), cubic metres per hour (m³/h) etc.

It should be noted that there is a perfect analogy between the flow of water through a pipe and the flow of electricity through a wire. It is sufficient to remember that hydraulic head is equivalent to electrical potential or voltage, and hydraulic flow is equivalent to electric current or amperes in electrotechnics. Even their behaviour is the same. Just as a thin wire restricts the flow of electricity more than one with a larger section, in the same way, a pipe of a smaller diameter offers a greater resistance to the flow of a liquid than one of a larger one. Just as the passage of electric current through the wire to a cable needs a voltage difference, in the same way, the flow of a liquid or fluid through a pipe needs a certain head.

There will never be a movement of liquid between two points of a perfectly horizontal pipe, and with the liquid at the same head in both points. This is due to the fact that, in the same way as the cable exerts a certain resistance to the passage of the electric current (electric resistance), the pipe also exerts a certain resistance to the passage of the fluid, the extent of which depends on the quality of the pipe (material, shape, presence of scale) and its section, and therefore the speed at which the fluid runs through the pipe. This resistance is called head loss.

HEAD LOSS

Head loss is that part of the head, possessed by the liquid, which is lost when passing through a pipe, a valve, a filter, etc. This loss cannot be recovered, as it is lost due to friction. Going back to the analogy between electrical and hydraulic phenomena, just as the losses in a cable increase in proportion with the current, so head losses are proportionally greater as the speed of the liquid increases. This means that the more the flow is restricted by scaled pipes, clogged filters, partially closed valves etc. the greater the head loss will be.

PUMP

A pump is a machine used to give a certain head to a liquid that passes through it. The head can be used to raise the liquid to a higher level, or to make it flow inside a pipe, or even in the open air, so that it covers a certain distance. The characteristics of a pump are:

- Flow** (the quantity of liquid that is moved through the pump in a unit of time).
- Head** (that is the height at which the pump is capable lifting the flow).

Based on the existing relationship between the flow and the head, it is possible to have:

- Pumps with small flow and large head (piston pumps, rotary pumps, small centrifugal pumps).
- Pumps with medium flow and medium head (centrifugal pumps in general).
- Pumps with large flow and small head (helico-centrifugal pumps, propeller pumps).

Centrifugal pumps, helico-centrifugal pumps and propeller pumps have a rotary motion and their speed is universally measured in revolutions per minute

(rpm). With these machines operating at a given speed, for each given value of flow, there is only one value of head. This means that in order to increase or decrease the performance of these types of pumps, the operating speed must be varied accordingly. Basically, the liquid passing through the pump is supplied with energy that is related to the head and the speed of the liquid itself. This energy supplied within the unit of time is known as delivered power.

DELIVERED POWER

The delivered power is the power delivered by the pump to the liquid. The value of this delivered power depends on three factors: flow, head, and specific weight of the pumped liquid. The higher these three factors, the higher is the power delivered by the pump. For example, a pump delivering petrol does less work than when delivering sulphuric acid, because the specific weights of the two liquids are different.

In order to pump a liquid, a pump must be driven by a motor. In the vast majority of cases, this is either an electric, or an internal combustion motor. Electric motors use electric power, while internal combustion motors (engines) use oil or oil derivative fuels. The power that the pump needs in order to operate is called absorbed power.

DELIVERED POWER CALCULATION

Delivered power is normally expressed in kW or HP, indicating with:

Q = the flow

H = the head in metres of the column of liquid (m.c.l.)

γ = the specific weight of the liquid

The delivered power (P3) is calculated using one of the following equations:

$$P3 = \frac{\gamma \text{ (kg/dm}^3\text{)} \times Q \text{ (l/s)} \times H \text{ (m.c.l.)}}{75} \text{ in HP}$$

$$P3 = \frac{\gamma \text{ (kg/dm}^3\text{)} \times Q \text{ (m}^3\text{/h)} \times H \text{ (m.c.l.)}}{270} \text{ in HP}$$

$$P3 = \frac{\gamma \text{ (kg/dm}^3\text{)} \times Q \text{ (l/s)} \times H \text{ (m.c.l.)}}{102} \text{ in kW}$$

$$P3 = \frac{\gamma \text{ (kg/dm}^3\text{)} \times Q \text{ (l/min)} \times H \text{ (m.c.l.)}}{4500} \text{ in HP}$$

$$P3 = \frac{\gamma \text{ (kg/dm}^3\text{)} \times Q \text{ (m}^3\text{/h)} \times H \text{ (m.c.l.)}}{367} \text{ in kW}$$

$$P3 = \frac{\gamma \text{ (kg/dm}^3\text{)} \times Q \text{ (l/min)} \times H \text{ (m.c.l.)}}{6120} \text{ in kW}$$

ABSORBED POWER

Absorbed power is the power that the pump absorbs from the motor, to give to the liquid the delivered power discussed above.

Not all the absorbed power becomes delivered power, as some power is lost through friction, and even more within the pump itself, due to hydraulic losses. It is therefore clear that the delivered power is always less than the absorbed power, and the relation between the two is a number always lower than 1. This number is known as the efficiency.

YIELD

The efficiency is obtained by dividing the delivered power by the absorbed power, and is normally expressed as a percentage. For example, an efficiency of 75 % of a pump indicates that only 75 % of the absorbed power is converted into delivered power, with the remaining 25 % being lost due to friction. Therefore, the higher the efficiency of a pump, the smaller the portion of absorbed power being lost. If one then considers that the cost of energy relates to the absorbed power, it immediately becomes apparent just how important efficiency is. If we compare two pumps with the same 1 HP delivered power, but with an efficiency of 50 % for the first, and 60 % for the second, we can assume that the first one will need 2 HP to supply 1, while the second will only need 1,67 HP to achieve the same result. This means that the efficiency of a pump expresses, better than any other parameter, the quality of the pump and the related savings in terms of operating costs.

CALCULATION OF POWER OUTPUTS

P1: is the power absorbed by the motor in kW (generally indicated by the wattmeter).

P2: the power delivered by the motor in kW. This is measured at the brake (it basically is the power absorbed by the pump).

P3: the power delivered by the pump in kW.

$$\text{Power output of the motor } \eta = \frac{P_2}{P_1}$$

$$\text{Power output of the motor } \eta = \frac{P_3}{P_2}$$

$$\text{Power output of the motor } \eta = \frac{P_3}{P_1}$$

THE HEAD OF A PUMP AND ITS MEASUREMENT

The head of a pump is always the differential head, or that given by the pump itself. This is generally expressed in metres. In order to ascertain the head of a surface pump, during its operation it is necessary to measure the value of the head both at the suction and at the delivery of the pump itself, making sure that the readings are taken at the same level, which is called the reference plane. Two cases are possible, depending on installation:

- 1) the value of the head at the suction is negative (i.e. below zero shown on the manometer): in this case, the level of the liquid collected is lower than the level of the suction inlet.
- 2) the value of the head at the suction is positive (i.e. above zero shown on the manometer) in this case, the level of the liquid collected is higher than the level of the suction inlet (flooded suction).

In the first case the head of the pump is given by the sum of the two readings, while in the second it is given by subtracting the value of the head at the suction inlet from the value at the delivery outlet.

Finally, it is necessary to make sure that the readings at the suction and the delivery have been taken from apertures of the same diameter, so that they are not distorted by a difference in the speed of the liquid at the point of measurement. Any correction is made by calculating the dynamic head, or that part of the head linked with the speed of the liquid, which means that part of the head that the liquid possesses at the measuring section, due to the fact that it is moving. The dynamic head H_d , expressed in metres, is calculated using the following formula:

$$H_d = \frac{v^2}{2g}$$

where: v = speed of the fluid at the measuring point, given in m/s

g = acceleration of gravity (9,81), expressed in m/s^2

$2g = 2 \times 9,81 = 19,62 \text{ m/s}^2$

The correction of the head is given by the difference between the dynamic head at the delivery, and the dynamic head at the suction. It is therefore clear that if the readings upstream and downstream the pump have been taken on pipes of the same diameter, and therefore with the liquid flowing at the same speed, the correction is zero.

In order to ascertain the head of a submerged impeller pump, it is sufficient, during operation, to measure the head at the delivery port. In this case, the head of the pump is given by adding the value read to the dynamic head (always at the delivery port), and to the difference of level between the free surface of the liquid collected and the manometer.

VARIATION IN PUMP HEAD IN RELATION TO SPEED VARIATION

The performance of a pump is directly connected to its speed in rpm (n). Providing that there is no cavitation, the law of similarity may be used, which is expressed as follows:

$$Q_x = Q \times \frac{n_x}{n}$$

$$H_x = H \times \left(\frac{n_x}{n}\right)^2$$

$$P_{2-x} = P_2 \times \left(\frac{n_x}{n}\right)^3$$

For example, when doubling the number of revolutions (n_x) one obtains:

Q_x = the value of the flow doubles

H_x = the value of the head is 4 times higher

P_{2-x} = the value of the absorbed power is 8 times higher

$Q - H - P_2$ are the values at speed n

$Q_x - H_x - P_{2-x}$ are the values at speed n_x .

NOTES ON THE MOTORS OF ELECTRIC PUMPS

INDEX OF SYMBOLS USED	
P_1	: POWER ABSORBED BY THE MOTOR IN kW.
P_2	: POWER DELIVERED BY THE MOTOR IN kW OR HP.
$V \sim$	= AC POWER INPUT VOLTAGE AT THE MAINS.
Hz	= FREQUENCY IN CYCLES PER SECOND OF THE POWER INPUT VOLTAGE.
I	= CURRENT ABSORBED BY THE MOTOR IN AMPERES.
$\cos\varphi$	= POWER FACTOR.
$n^{1/min}$	= SPEED OF ROTATION IN RPM.
η	= OUTPUT POWER (RELATION BETWEEN DEVELOPED POWER AND ABSORBED POWER P_2/P_1).
p	= NUMBER OF POLES OF THE MOTOR.
Cn	= NOMINAL TORQUE OF THE MOTOR.

NO-LOAD SPEED OF ROTATION

The no-load speed of single-phase and three-phase electric induction motors is given by the formula:

$$n^{1/min} = \frac{120 \times \text{Hz}}{p}$$

No-load speed of rotation $n^{1/min}$

FREQUENCY Hz	2 POLES	4 POLES
50	3000	1500
60	3600	1800

The full-load speed is 2 to 7 % lower than the no-load speed (2 to 7 % sliding).

CURRENT ABSORBED

$$\text{Single-phase: } I = \frac{1000 \times P_2 \text{ (kW)}}{V \times \cos\varphi \times \eta} \quad \text{or: } I = \frac{736 \times P_2 \text{ (HP)}}{V \times \cos\varphi \times \eta}$$

$$\text{Three-phase: } I = \frac{1000 \times P_2 \text{ (kW)}}{1.73 \times V \times \cos\varphi \times \eta} \quad \text{or: } I = \frac{736 \times P_2 \text{ (HP)}}{1.73 \times V \times \cos\varphi \times \eta}$$

ABSORBED POWER

$$\text{Single-phase: } P_1 \text{ (kW)} = \frac{V \times I \times \cos\varphi}{1000}$$

$$\text{Three-phase: } P_1 \text{ (kW)} = \frac{1.73 \times V \times I \times \cos\varphi}{1000}$$

POWER DELIVERED AT THE MOTOR AXIS

$$\text{Single-phase: } P_2 \text{ (kW)} = \frac{V \times I \times \cos\varphi \times \eta}{1000} \quad \text{or: } P_2 \text{ (HP)} = \frac{V \times I \times \cos\varphi \times \eta}{736}$$

$$\text{Three-phase: } P_2 \text{ (kW)} = \frac{1.73 \times V \times I \times \cos\varphi \times \eta}{1000} \quad \text{or: } P_2 \text{ (HP)} = \frac{1.73 \times V \times I \times \cos\varphi \times \eta}{736}$$

YIELD

$$\eta = \frac{P_2 \text{ (kW)}}{P_1 \text{ (kW)}}$$

POWER FACTOR

$$\text{Single-phase: } \cos\varphi = \frac{P_2 (\text{kW}) \times 1000}{V \times I \times \eta}$$

$$\text{or: } \cos\varphi = \frac{P_1 (\text{kW}) \times 1000}{V \times I}$$

$$\text{Three-phase: } \cos\varphi = \frac{P_2 (\text{kW}) \times 1000}{1,73 \times V \times I \times \eta}$$

$$\text{or: } \cos\varphi = \frac{P_1 (\text{kW}) \times 1000}{1,73 \times V \times I}$$

TORQUE FACTOR

$$C_n = \frac{P_2 (\text{kW}) \times 1000}{1,027 \times n^{1/\text{min}}} \text{ in kgm}$$

$$C_n = \frac{P_2 (\text{HP}) \times 736}{1,027 \times n^{1/\text{min}}} \text{ in kgm}$$

$$C_n = \frac{702 \times \text{HP}}{n^{1/\text{min}}} \text{ in decaNewtonmetres}$$

RELATIONSHIP BETWEEN KW AND HP

$$1 \text{ HP} = 0,736 \text{ kW}$$

$$1 \text{ kW} = 1,36 \text{ HP}$$

$$\frac{\text{HP}}{1,36} = \text{kW}$$

$$\text{kW} \times 1,36 = \text{HP}$$

STARTING CURRENT (ISP)

The starting current (at switch on) of a motor is 4 to 8 times greater than the nominal current, depending on the power of the motor.

$$I_{sp} = I_n \times 4 \div 8$$

DETAILS ON CAPACITORS

The approximate current absorbed by a capacitor is:

$$I = \frac{6,28 \times F \times C \times V}{1,000,000}$$

Where:

I = current in Amps absorbed by the capacitor.

F = frequency in Hz of the applied voltage.

C = capacity of capacitor μF .

V = applied voltage.

Example:

The current absorbed by a 14 μF capacitor connected to a 220 Volt - 50 Hz power input is:

$$I = \frac{6,28 \times 50 \times 14 \times 220}{1,000,000} = 0,96 \text{ Amperes}$$

The approximate capacity of a capacitor is determined by:

$$C = \frac{I}{6,28 \times F \times V} \times 1,000,000$$

Example:

The capacity of a capacitor that absorbs 1,4 Amperes connected to a 220 Volt - 50 Hz power input is:

$$C = \frac{1,4}{6,28 \times 50 \times 220} \times 1,000,000 = 20,2 \mu\text{F}$$

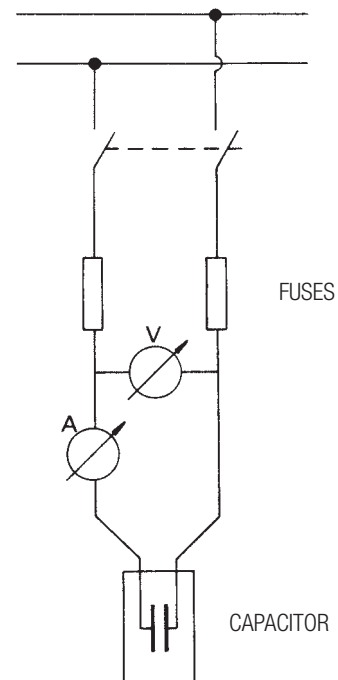

STAR-DELTA START-UP

The normally delta Δ connected motor is connected to the network using a star type connection. The current and the starting torque are both reduced to 1/3 of the value they would be if delta Δ connected.

PROTECTION

It is recommended that motors are connected to the power input network using appropriate three-fuse thermal magnetic circuit breakers, or in any case circuit breakers complying with current local regulations.

LOAD LOSS AND SPEED TABLE

In order to accurately calculate **load losses and speed**, the following table is used:

FLOW			NEW GALVANISED PIPING									
			NOMINAL DIAMETERS: INCHES AND MM									
l/s	l/min	m ³ /h	1/2"	3/4"	1"	1"1/4	1"1/2	2"	2"1/2	3"	3"1/2	4"
			15,75	21,25	27	35,75	41,25	52,5	68	80,25	92,5	105
0,17	10	0,6	0,856	0,47	0,291							
			9,01	20,9	0,65							
0,25	15	0,9	1,284	0,705	0,4387	0,249						
			19,07	4,43	1,38	0,35						
0,33	20	1,2	1,712	0,94	0,582	0,332	0,25					
			32,47	7,55	2,35	0,6	0,3					
0,42	25	1,5	2,14	1,175	0,728	0,415	0,31					
			49,06	11,41	3,55	0,91	0,45					
0,5	30	1,8	2,568	1,411	0,874	0,498	0,37	0,23				
			68,74	15,98	4,98	1,27	0,63	0,2				
0,58	35	2,1	2,996	1,646	1,019	0,581	0,44	0,27				
			91,42	21,26	6,62	1,69	0,84	0,26				
0,67	40	2,4		1,881	1,165	0,664	0,5	0,31				
				27,22	8,48	2,16	1,08	0,33				
0,83	50	3		2,351	1,456	0,831	0,62	0,39	0,23			
				41,13	12,81	3,27	1,63	0,5	0,14			
1	60	3,6		2,821	1,747	0,997	0,75	0,46	0,28			
				57,63	17,95	4,58	2,28	0,7	0,2			
1,17	70	4,2		3,291	2,039	1,163	0,87	0,54	0,32	0,23		
				76,64	23,88	6,08	3,03	0,94	0,27	0,12		
1,33	80	4,8			2,33	1,329	1	0,62	0,37	0,26		
					30,57	7,79	3,88	1,2	34	0,15		
1,5	90	5,4			2,621	1,495	1,12	0,69	0,41	0,3		
					38,01	9,69	4,83	1,49	0,42	0,19		
1,67	100	6			2,912	1,661	1,25	0,77	0,46	0,33	0,25	
					46,19	11,77	5,86	1,81	0,51	0,23	0,11	
2,08	125	7,5			3,641	2,077	1,56	0,96	0,57	0,41	0,31	0,24
					69,79	17,79	8,86	2,74	0,78	0,35	0,17	0,09
2,5	150	9				2,492	1,87	1,16	0,69	0,49	0,37	0,29
						24,92	12,41	3,84	1,09	0,49	0,24	0,13
2,92	175	10,5				2,907	2,18	1,35	0,8	0,58	0,43	0,34
						33,15	16,51	5,1	1,45	0,65	0,32	0,17

White numbers: Load losses in m. for every 100 m of pipework

Green numbers: Water speed in m/sec

The table refers to galvanised pipework.

For other materials multiply as follows:

- 0,6 PVC pipes.
- 0,7 aluminium pipes.
- 0,8 laminated steel and stainless steel.

LOAD LOSS AND SPEED TABLE

In order to accurately calculate **load losses and speed**, the following table is used:

FLOW			NEW GALVANISED PIPING										
			NOMINAL DIAMETERS: INCHES AND MM										
l/s	l/min	m³/h	1"1/4	1"1/2	2"	2"1/2	3"	3"1/2	4"	5"	6"	8"	
			35,75	41,25	52,5	68	80,25	92,5	105	130	155	206	
3,33	200	12	3,322	2,5	1,54	0,92	0,66	0,5	0,39	0,25			
			42,43	21,14	6,53	1,85	0,83	0,41	0,22	0,08			
4,17	250	15	4,156	3,12	1,93	1,15	0,82	0,62	0,48	0,31			
			64,12	31,94	9,87	2,8	1,25	1,63	0,34	0,12			
5	300	18	3,74	2,31	1,38	0,99	0,74	0,58	0,38	0,27			
			44,75	13,83	3,92	1,75	0,88	0,47	0,17	0,07			
6,67	400	24	4,99	3,08	1,84	1,32	0,99	0,77	0,5	0,35			
			76,2	23,55	6,68	2,98	1,49	0,8	0,28	0,12			
8,33	500	30	3,85	2,3	1,65	1,24	0,96	0,63	0,44				
			35,58	10,09	4,51	2,26	1,22	0,43	0,18				
10	600	36	4,62	2,75	1,98	1,49	1,16	0,75	0,53	0,3			
			49,85	14,14	6,31	3,16	1,7	0,6	0,26	0,06			
11,67	700	42	3,21	2,31	1,74	1,35	0,88	0,62	0,35				
			18,81	8,4	4,2	2,27	0,8	0,34	0,09				
13,33	800	48	3,67	2,64	1,99	1,54	1,01	0,71	0,4				
			24,08	10,75	5,38	2,9	1,03	0,44	0,11				
15	900	54	4,13	2,97	2,23	1,73	1,13	0,8	0,45				
			29,94	13,37	6,69	3,61	1,28	0,54	0,14				
16,67	1000	60	4,59	3,3	2,48	1,93	1,26	0,88	0,5				
			36,39	16,24	8,13	4,39	1,55	0,66	0,16				
20,83	1250	75	4,12	3,1	2,41	1,57	1,1	0,63					
			24,54	12,29	6,63	2,34	0,99	0,25					
25	1500	90	4,95	3,72	2,89	1,88	1,33	0,75					
			34,39	17,22	9,29	3,28	1,39	0,35					
29,17	1750	105	4,34	3,37	2,2	1,55	0,88						
			22,9	12,35	4,37	1,85	0,46						
33,33	2000	120	4,96	3,85	2,5	1,77	1						
			29,31	15,81	5,59	2,37	0,59						
41,67	2500	150	4,81	3,14	2,21	1,25							
			23,89	8,44	3,59	0,9							
50	3000	180	HAZEN WILLIAMS CALCULATION FORMULA (UNI 9489 13.3.3.6)				3,77	2,65	1,5				
							11,83	5,02	1,26				
5,03	3,53	2											
20,15	8,55	2,14											
83,33	5000	300					4,42	2,5					
							12,93	3,23					

White numbers: Load losses in m. for every 100 m of pipework

Green numbers: Water speed in m/sec

The table refers to galvanised pipework.

For other materials multiply as follows:

- 0,6 PVC pipes.
- 0,7 aluminium pipes.
- 0,8 laminated steel and stainless steel.

HEAD LOSS

in cm of column of water in bends, gate valves, and foot valves

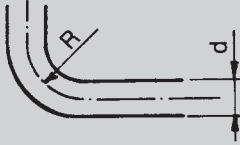
VELOCITY OF WATER IN m/s	SHARP EDGED BENDS					NORMAL BENDS					GATE VALVE	FOOT VALVE	NON-RETURN VALVE	HEAD LOSS ON EXIT FROM PIPES $V^2 \cdot 2g$
														
	$\alpha = 30^\circ$	$\alpha = 40^\circ$	$\alpha = 60^\circ$	$\alpha = 80^\circ$	$\alpha = 90^\circ$	$\frac{d}{R} = 0,4$	$\frac{d}{R} = 0,6$	$\frac{d}{R} = 0,8$	$\frac{d}{R} = 1$	$\frac{d}{R} = 1,5$				
0,10	0,03	0,04	0,05	0,07	0,08	0,07	0,08	0,01	0,0155	0,027	0,03	30	30	0,05
0,15	0,06	0,73	0,1	0,14	0,17	0,016	0,019	0,024	0,033	0,06	0,033	31	31	0,12
0,2	0,11	0,13	0,18	0,26	0,31	0,028	0,033	0,04	0,059	0,11	0,058	31	31	0,21
0,25	0,17	0,21	0,28	0,4	0,48	0,044	0,052	0,063	0,091	0,17	0,09	31	31	0,32
0,3	0,25	0,3	0,41	0,6	0,7	0,063	0,074	0,09	0,13	0,25	0,13	31	31	0,46
0,35	0,33	0,4	0,54	0,8	0,93	0,085	0,10	0,12	0,18	0,33	0,18	31	31	0,62
0,4	0,43	0,52	0,71	1,0	1,2	0,11	0,13	0,16	0,23	0,43	0,23	32	31	0,82
0,5	0,67	0,81	1,1	1,6	1,9	0,18	0,21	0,26	0,37	0,67	0,37	33	32	1,27
0,6	0,97	1,2	1,6	2,3	2,8	0,25	0,29	0,36	0,52	0,97	0,52	34	32	1,84
0,7	1,35	1,65	2,2	3,2	3,9	0,34	0,40	0,48	0,70	1,35	0,7	35	32	2,5
0,8	1,7	2,1	2,8	4,0	4,8	0,45	0,53	0,64	0,93	1,7	0,95	36	33	3,3
0,9	2,2	2,7	6	5,2	6,2	0,57	0,67	0,82	1,18	2,2	1,2	37	34	4,2
1,0	2,7	3,3	4,5	6,4	7,6	0,7	0,82	1,0	1,45	2,7	1,45	38	35	5,1
1,5	6,0	7,3	10,0	14,0	17,0	1,6	1,9	2,3	3,3	6,0	3,3	47	40	11,5
2,0	11,0	14,0	18,0	26,0	31,0	2,8	3,3	4,0	5,8	11,0	5,8	61	48	20,4
2,5	17,0	21,0	28,0	40,0	48,0	4,4	5,2	6,3	9,1	17,0	9,1	78	58	32,0
3,0	25,0	30,0	41,0	60,0	70,0	6,3	7,4	9,0	13,0	25,0	13,0	100	71	46,0
3,5	33,0	40,0	55,0	78,0	93,0	8,5	10,0	12,0	18,0	33,0	18,0	123	85	62,0
4,0	43,0	52,0	70,0	100,0	120,0	11,0	13,0	16,0	23,0	42,0	23,0	150	100	82,0
4,5	55,0	67,0	90,0	130,0	160,0	14,0	21,0	26,0	37,0	55,0	37,0	190	120	103,0
5,0	67,0	82,0	110,0	160,0	190,0	18,0	29,0	36,0	52,0	67,0	52,0	220	140	127,0

v = velocity of water in metres per second

d = diameter of pipes in m metres

h = head loss in cm of water column for each metre of pipework, calculated according to the Lang formula:

$$h = \lambda \times \frac{100}{d} \times \frac{v^2}{2g} \qquad \lambda = 0,02 + \frac{0,0018}{\sqrt{v \times d}}$$

The only loss in bends is that due to the contraction of the liquid stream when changing direction (the development of the curves must therefore be included in the length of the pipework); the head loss for gate valves has been determined through technical tests.

The head loss for gate valves and normal bends is equal to that of 5 m of straight pipework, while that of non-return valves is equal to 15 m.

The values given are for pipes with a completely smooth internal surface. In case of rough or scaled pipes, allowances must be made accordingly.

VAPOUR TENSION AND SPECIFIC WEIGHT OF WATER AS A FUNCTION OF TEMPERATURE

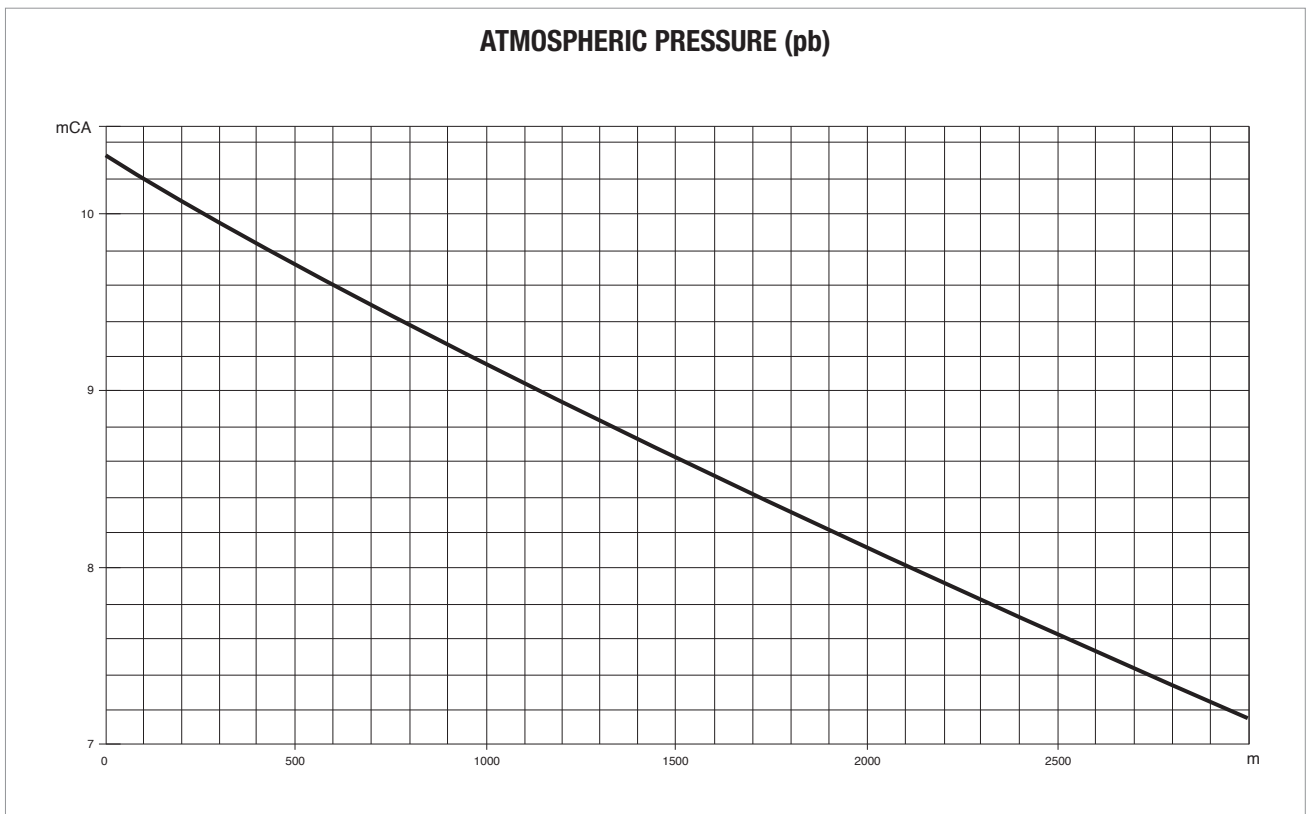
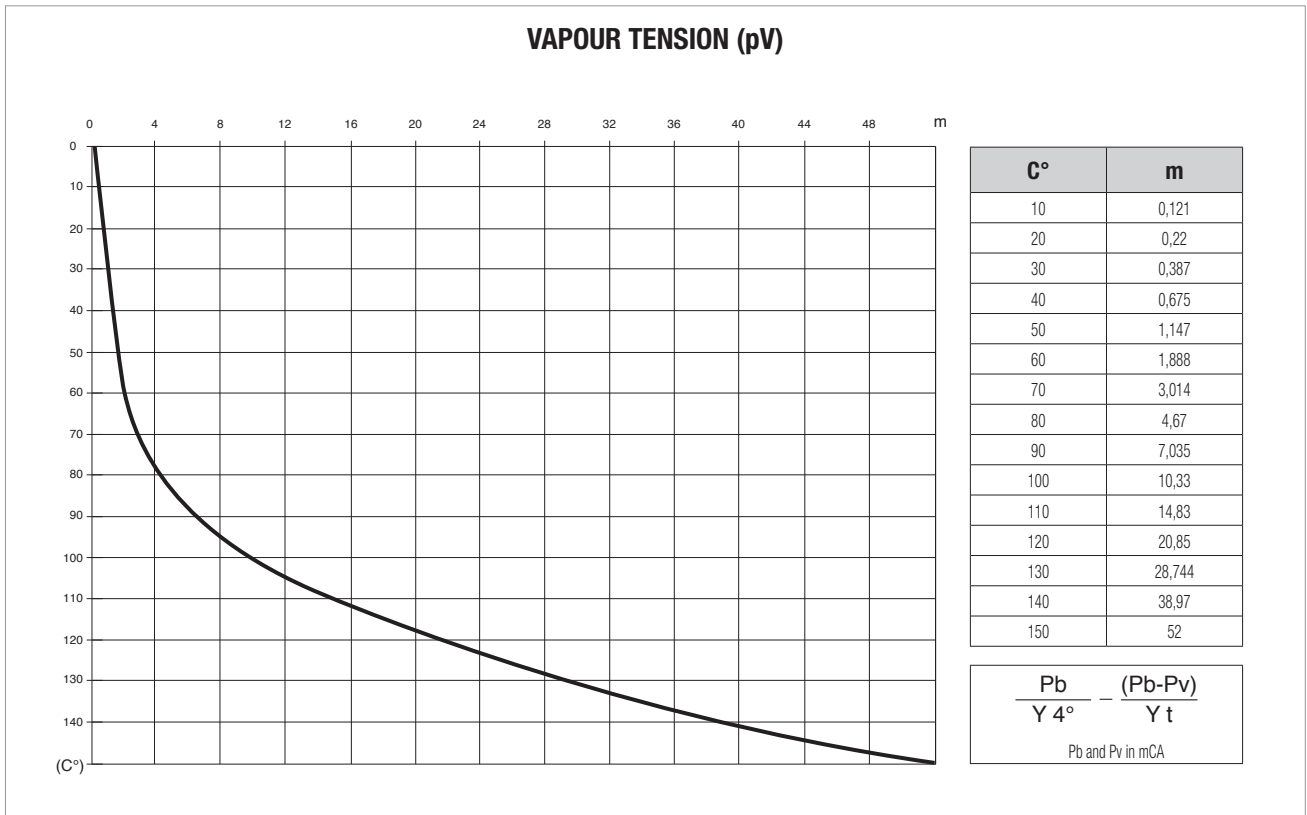

CONVERSION TABLE FOR UNITS OF MEASURE

CHARACTERISTIC	SYSTEM UNIT OF MEASURE	UNIT OF MEASURE	SYMBOL	CONVERSIONS		
				SYSTEM	INTERNATIONAL SYSTEM (SI)	IMPERIAL SYSTEM
LENGTH	Technical and International	metre decimetre centimetre millimetre	m dm cm mm	1 dm = 0,1 m 1 cm = 0,01 m 1 mm = 0,001 m		1 m = 3,28 ft 1 dm = 3,937 in 1 cm = 0,3937 in
	Imperial	inch foot yard	1", in 1", ft yd	1" = 25,4 mm 1" ft = 0,3048 m 1 yd = 0,9144 m		1 ft = 12" 1 yd = 3 ft = 26"
AREA	Technical and International	metres squared centimetres squared millimetres squared	m ² cm ² mm ²	1 cm ² = 0,0001 m ² 1 mm ² = 0,01 cm ²		1 m ² = 1,196 sq.yd 1 m ² = 10,764 sq.ft 1 cm ² = 0,155 sq.in
	Imperial	square inch square foot square yard	sq.in sq.ft sq.yd	1 sq.in = 6,45 cm ² 1 sq.ft = 0,0929 m ² 1 sq.yd = 0,836 m ²		1 sq.ft = 144 sq.in 1 sq.yd = 1,296 sq.in 1 sq.yd = 9 sq.ft
VOLUME	Technical and International	metre cubed decimetre cubed centimetre cubed litre cubed	m ³ cm ³ mm ³ l	1 m ³ = 1.000 dm ³ 1 cm ³ = 0,001 m ³ = 1.000 cm ³ 1 mm ³ = 0,001 dm ³ 1 l = dm ³		1 dm ³ = 0,22 Imp.gal 1 dm ³ = 0,264 US.gal 1 dm ³ = 61,0 cu.in
	Imperial	cubic inch cubic feet Imperial gallons U.S. gallons	cu.in cu.ft Imp.gal USA.gal	1 cu.in = 16,39 cm ³ 1 cu.ft = 28,34 m ³ 1 Imp.gal = 4,546 m ³ 1 US.gal = 3,785 dm ³		1 Imp.gal = 1,201 US.gal 1 US.gal = 0,833 Imp.gal
TEMPERATURE	Technical and International	degrees Centigrade degrees Kelvin	°C °K	°C = °K - 273 °K = °C + 273		°C = 5/9 x (°F - 32) °K = 5/9 x (°F - 32) + 273
	Imperial	degrees Fahrenheit	°F	°F = 9/5 x °C + 32		-
		freezing point of water at atmospheric pressure: boiling point of water at atmospheric pressure:		000°C = 273 °K = 032 °F 100°C = 373 °K = 212 °F		
WEIGHT and FORCE	Technical	kilogram	kg	-	1 kg = 9,81 N	1 kg = 2,203 lb
	International	Newton	N	1 N = 0,102 kg	-	1 N = 0,22546 lb
	Imperial	pound	lb	1 lb = 0,454 kg	1 lb = 4,452 N	-
SPECIFIC WEIGHT	Technical	kilogram per decimetre cubed	kg/dm ³	-	1 kg/dm ³ = 9,807 N/dm ³	1 kg/dm ³ = 62,46 lb/cu.ft
	International	Newton per decimetre cubed	N/dm ³	1 N/dm ³ = 0,102 kg/dm ³	-	1 N/dm ³ = 6,36 lb/cu.ft
	Imperial	pound per cubic foot	lb/dm ³	1 lb/cu.ft = 0,01600 kg/dm ³	1 lb/cu.ft = 0,160 N/dm ³	-
PRESSURE	Technical	atmospheres	kg/cm ²	-	1 kg/cm ² = 98,067 kPa 1 kg/cm ² = 0,9807 bar	1 kg/cm ² = 14,22 psi
	International	Pascal kiloPascal bar	Pa kPa bar	1 kPa = 0,0102 kg/cm ² 1 bar = 1,02 kg/cm ²	1 kPa = 1.000 Pa 1 bar = 100.000 Pa	1 kPa = 0,145 psi 1 bar = 14,50 psi
	Imperial	pounds per square inch	psi	1 psi = 0,0703 kg/cm ²	1 psi = 0,06895 bar 1 psi = 6,894 kPa	-
FLOW	Technical	litres per minute litres per second metres cubed per hour	l/min l/s m ³ /h	1 l/min = 0,0167 l/s 1 l/s = 3,6 m ³ /h 1 m ³ /h = 16,667 l/min	1 l/s = 0,001 m ³ /s	1 l/min = 0,22 imp.g.p.m. 1 l/min = 0,264 US.g.p.m. 1 m ³ /h = 3,666 imp.g.p.m. 1 m ³ /h = 4,403 US.g.p.m.
	International	metres cubed per second	m ³ /s	1 m ³ /s = 1.000 l/s 1 m ³ /s = 3.600 m ³ /h	-	1 m ³ /s = 13,198 imp.g.p.m. 1 m ³ /s = 15,852 US.g.p.m.
	Imperial	imperial gallon per minute U.S. gallons per minute	Imp.g.p.m. US.g.p.m.	1 Imp.g.p.m. = 4,546 l/min 1 Imp.g.p.m. = 0,273 m ³ /h 1 US.g.p.m. = 3,785 l/min 1 US.g.p.m. = 0,227 m ³ /h	-	1 Imp.g.p.m. = 1,201 US.g.p.m. 1 US.g.p.m. = 0,833 Imp.g.p.m.
TORQUE	Technical	kilogram metre	kgm	-	1 kgm = 9,807 Nm	1 kgm = 7,233 ft.lb
	International	Newton metre	Nm	1 Nm = 0,102 kgm	-	1 Nm = 0,7376 ft.lb
	Imperial	foot pound	ft.lb	1 ft.lb = 0,138 kgm	1 ft.lb = 1,358 Nm	-
WORK and ENERGY	Technical	kilogram metre vapour-horsepower hour	kgm CVh		1 kgm = 9,807 J 1 CVh = 0,736 kWh	1 kgm = 7,233 ft.lb 1 Nm = 0,986 HP.hr.
	International	Joule kiloWatt hour	J kWhq	1 J = 0,102 kgm kWh = 1,36 CVh	-	1 Nm = 0,7376 ft.lb 1 Nm = 0,7376 ft.lb
	Imperial	foot pound Horsepower hour	ft.lb HP.hr.	1 ft.lb = 0,138 kgm 1 HP.hr. = 1,014 CVh	1 ft.lb = 0,358 Nm 1 HP.hr. = 0,746 kWh	-
POWER	Technical	Horse power	HP	1 HP = 0,736 kW	1 HP = 736 W	-
	International	Watt kiloWatt	W kW	1 W = 0,00136 Hp 1 kW = 1,36 Hp	1 kW = 1.000 W	-
KINETIC VISCOSITY	Technical	stokes centistokes	1 St 1 cSt	1 St = 1 cm ² /s 1 cSt = 0,01 St	1 St = 0.0001 m ² /s	1 St = 0.00107 ft ² /s
	International	m ² /s	m ² /s	1 m ² /s = 10.000 St	1 m ² /s = 10.000 cm ² /s	1 m ² /s = 10.764 ft ² /s
	Imperial	square foot per second	ft ² /s	1 ft ² /s = 929 St	1 ft ² /s = 0.0929 m ² /s	-



TECHNICAL DATA

Line voltage: 115V e 230V single phase. 400V three-phase.
Electric pump voltage: 115V e 230V single phase, 230V e 400V three-phase.
Frequency: 50 Hz - 60 Hz.
Installation: vertical or horizontal (for M/M e M/T).
Max. Liquid temperature: 50°C.
Max. operational temperature: 60°C.
Portata max: 15m³/h.
Max. pressure: 13 bar.
Pressure regulation range: from 1 to 13 bar.
Aspiration diameter (DNA): 1 1/4" male.
Discharge diameter (DNM): 1 1/2" female.
Protection rating: IP55.
Communication interface for sets: Yes, an Active Driver per pump.

APPLICATIONS

The units with Active Driver were designed and manufactured to meet the needs for constant **pressure required** by modern plumbing systems. Constant pressure regulation is applicable to many sectors: Water supply for irrigation, industry, hotels, housing construction, thermal baths. The basic concept that guided our Engineers in the development of these units was to manufacture a system that is **simple, flexible and reliable**.

ADVANTAGES

Constant pressure - Quiet operation - Economical - Reduced water consumption - Smaller footprint (Expansion tanks not required) Less maintenance - Dry-running protection - Complete protection of the pump from faults.

ACTIVE DRIVER NOTES

The Active Driver inverter is a pump control device that includes the connections to the hydraulic system, a pressure sensor, a flow sensor, and an electronic frequency inverter. Active Driver is applied on the delivery of **each electric pump**, and regulates the rotation speed of the pump it is connected to, so that the **pressure is kept constant** in spite of variations in the required flow rate. The water flowing through the Active Driver Plus connections also contributes to **eliminating the heat** produced by the internal electric components.

OPERATION

Active Driver orders the pump to start as soon as it detects a request of water. The speed of the pump is (consistently) regulated at the minimum value that meets the request of the user. This ensures important energy savings. In this set, the second and third pump are activated in cascade when the first pump reaches the maximum rotation speed. The pump pressure may be adjusted by the user using the + and - buttons on Active Driver (usually all of the pumps are set at the same pressure level).

The pumps stop automatically when there is:

Pump overload - dry-running - low voltage - Maximum pressure exceeded (adjustable) - Active Driver electronics overheating.

ACTIVE DRIVER FUNCTIONS DISPLAYED

Pump operational frequency (Hz) - Real-time pressure (bar) - Amperes absorbed by the pump - Alarms.

ACTIVE DRIVER EXTERNAL CONNECTIONS (models M/T 2.2 - T/T 3.0 - T/T 5.5 only)

Inputs: pump disabling, pressure switch, float against dry operation, second pressure setpoint.

Outputs: two terminals with no potential for signaling alarms, pump stop, pump running.

MATERIALS

N°	PARTS*	MATERIALS
1	ACTIVE DRIVER PLUS BODY	VERPLEN
2	THREADED BRASS INSERT - 1-1/2 GAS	BRASS
3	VNR HOUSING	NORYL
4 - 10 - 12 - 15 - 16 - 19	O-RING	NBR
5 - 20	O-RING	EPDM 70 WRAS
6	VNR GUIDE	NORYL
7	VNR BODY	NORYL
8	MAGNET	FERRITE + PARYLENE
9	VNR COVER	NORYL
11	O-RING	SILORPREN
13	SPRING SP1	STAINLESS STEEL
14	SCREW	STAINLESS STEEL
17	INSERT - 3/8" GAS	PPE 20GF
18	PRESSURE SENSOR	STAINLESS STEEL
21	HEAT DISPERSER	BRASS

* In contact with the liquid.

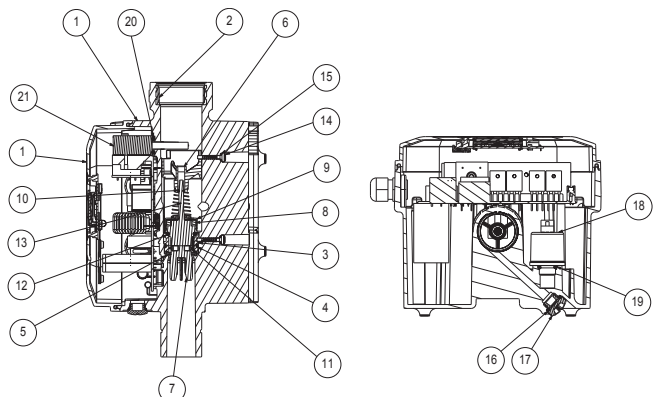

INVERTER

ACTIVE DRIVER PLUS

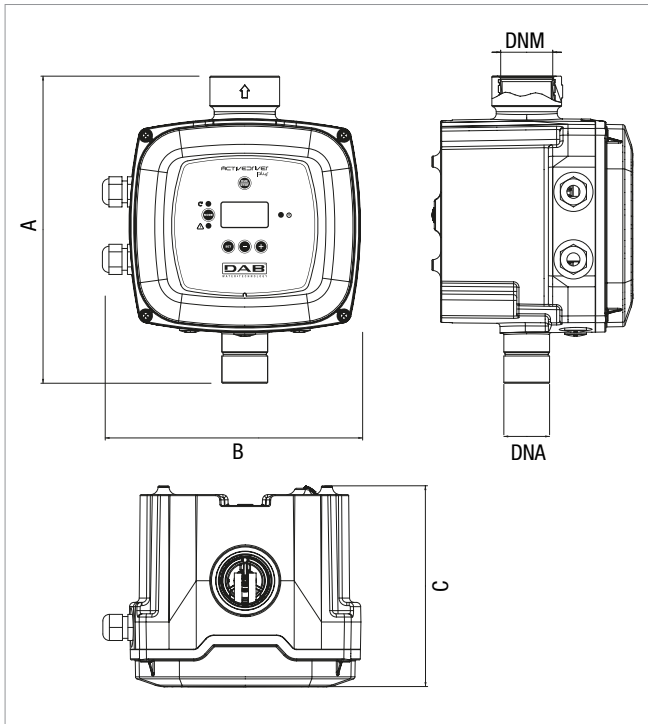

MODEL	A	B	C	DNM	DNA	PACKING DIMENSIONS			WEIGHT Kg
						L/A	L/B	H	
ACTIVE DRIVER PLUS M/M 1.1	237	282	185	1" 1/2F	1" 1/4M	340	270	220	3,5
ACTIVE DRIVER PLUS M/M 1.5	237	282	185	1" 1/2F	1" 1/4M	340	270	220	3,5
ACTIVE DRIVER PLUS M/M 1.8	237	282	185	1" 1/2F	1" 1/4M	340	270	220	3,8
ACTIVE DRIVER PLUS M/T 1.0	237	282	185	1" 1/2F	1" 1/4M	340	270	220	3,5
ACTIVE DRIVER PLUS M/T 2.2	237	282	185	1" 1/2F	1" 1/4M	340	270	220	3,5
ACTIVE DRIVER PLUS T/T 3.0	237	282	185	1" 1/2F	1" 1/4M	340	270	220	4,5
ACTIVE DRIVER PLUS T/T 5.5	237	282	185	1" 1/2F	1" 1/4M	340	270	220	4,6

MODEL	MAX CURRENT MOTOR A	MAX POWER MOTOR kW	POWER SUPPLY 50 Hz	POWER SUPPLY ELECTRIC PUMP	COMMUNICATION INTERFACE FOR SETS	USE WITH PUMP TYPE	ADJUSTMENT PRESSURE BAR
ACTIVE DRIVER PLUS M/M 1.1	8,5	1,1	Single phase 1x230	Single phase 1x230	YES	Surface pumps, submerged 4" and 5" with single phase motor with current draw up to 8.5 A	1-6
ACTIVE DRIVER PLUS M/M 1.5	11	0,55	Single phase 1x115	Single phase 1x115	YES	Surface pumps, submerged 4" and 5" with single phase motor with current draw up to 11 A	1-9
		1,5	1x230	1x230			
ACTIVE DRIVER PLUS M/M 1.8	14	1,0	Single phase 1x115	Single phase 1x115	YES	Surface pumps, submerged 4" and 5" with single phase motor with current draw up to 14 A	1-9
		1,8	1x230	1x230			
ACTIVE DRIVER PLUS M/T 1.0	4,7	1,0	Single phase 1x230	Three-phase 3x230	YES	Surface pumps, submerged 4" and 5" with 230 V three-phase motor with current draw up to 4.7 A	1-5
ACTIVE DRIVER PLUS M/T 2.2	10,5	2,2	Single phase 1x230	Three-phase 3x230	YES	Surface pumps, submerged 4" and 5" with 230 V three-phase motor with current draw up to 10.5 A	1-13
ACTIVE DRIVER PLUS T/T 3.0	7,5	3,0	Three-phase 3x400	Three-phase 3x400	YES	Surface pumps, submerged 4" and 5" with 400 V three-phase motor with current draw up to 7.5 A	1-13
ACTIVE DRIVER PLUS T/T 5.5	13,3	5,5	Three-phase 3x400	Three-phase 3x400	YES	Surface pumps, submerged 4" and 5" with 400 V three-phase motor with current draw up to 13.3 A	1-13



APPLICATIONS

The MCE/P family represents the new frontier of Dab inverters. These inverters are intended for complex professional applications. They can pilot three-phase pumps up to 15 kW. They combine the simplicity of the MCE/P series with the strength and power of the inverter. They must be fitted on the pump, and must be equipped with pressure sensors, and as optional with flow sensors. The latter guarantees improved pressure control. These models also permit the assembly of pressurisation units.

The MCE/P family combines comfort and savings, includes all the protection features, and is easy to install and configure.

WHY SHOULD I CHOOSE A DAB INVERTER?

The MCE/P inverters have the characteristics of being air cooled. They are extremely strong on-pump inverters, with a metal body and suitable for demanding applications. In order to operate, they require a pressure sensor. A flow sensor can also be installed as optional. MCE/P inverters combine comfort, with ease of installation and maintenance.

MCE/P inverters ensure maximum comfort and increase the average life of the system, also providing significant energy savings.

ADVANTAGES

- Easy to install in existing systems.
- Constant pressure.
- Up to 60% reduction in energy consumption.
- Built-in protections.
- Suitable for all pumps, with the exception of submerged pumps.
- Strong.
- Possibility of sets with interchange of up to 8 pumps.
- IP 55 protection class.

MODEL	MAXIMUM PUMP MECHANICAL POWER (P2) KW	MAX MOTOR NOMINAL CURRENT A	MIN MOTOR NOMINAL CURRENT A	POWER INPUT 50 Hz	ELECTRIC PUMP POWER INPUT	MOTOR SIZES (MEC)
MCE/P 11	1,1	6,5	1,0	Single-phase 1x230	Three-phase 3x230	71 80
MCE/P 15	1,5	8,0	1,0	Single-phase 1x230	Three-phase 3x230	90
MCE/P 22	2,2	10,5	1,0	Single-phase 1x230	Three-phase 3x230	90 100
MCE/P 30	3	7,5	2,0	Three-phase 3x400	Three-phase 3x400	100
MCE/P 55	5,5	13,5	2,0	Three-phase 3x400	Three-phase 3x400	112 132
MCE/P 110	11,0	24	2,0	Three-phase 3x400	Three-phase 3x400	132 160
MCE/P 150	15,0	32	2,0	Three-phase 3x400	Three-phase 3x400	160

SIZES AND WEIGHTS

MCE/P 11 - 15 - 22

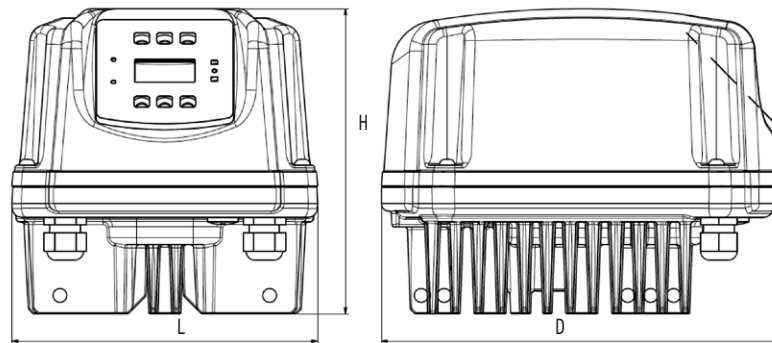

MCE/P 30 - 55

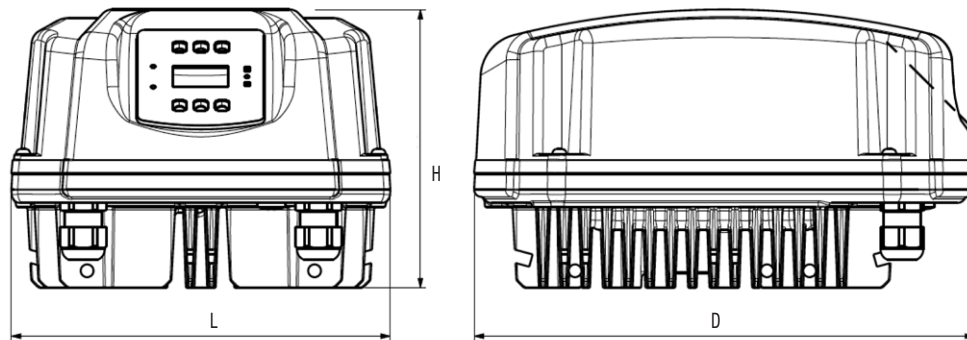

MCE/P 110 - 150

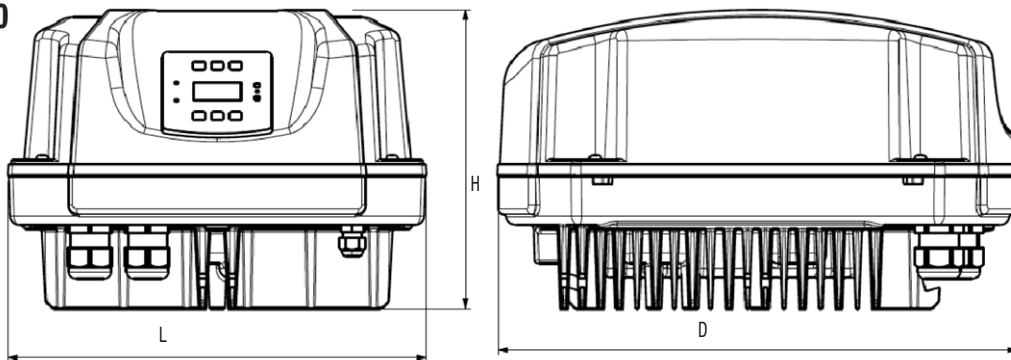

MODEL	L	H	D	PACKING DIMENSIONS			WEIGHT kg
				L/D	L/L	H	
MCE/P 11	200	199	262	265	235	215	5
MCE/P 15	200	199	262	265	235	215	5
MCE/P 22	200	199	262	265	235	215	5
MCE/P 30	267	196	352	360	280	200	7,6
MCE/P 55	267	196	352	360	280	200	7,6
MCE/P 110	343	244	425	435	345	265	12
MCE/P 150	343	244	425	435	345	265	12

NOTES ON THE MCE/P

The MCE/P family represents the new frontier of DAB inverters. MCE/P inverters are intended for complex professional applications. They can drive three phase electric pumps of up to 15 kW. They combine the simplicity of the MCE/P series with the strength and power of the inverter. They are installed on the pump itself, taking advantage of the motor cooling system. The MCE/P family combines comfort and savings, includes all the protection features, and is easy to install and configure.

ENERGY SAVING

Reducing, even for just one minute, the rotation speed of a motor, can bring significant energy savings, as the power consumed by an electric motor is proportional to the cube of the number of revolutions.

For example, a pump connected to the power network working at approximately 2950 rpm, if set to operate at 40 Hz, will turn at a speed approximately 20 % lower (approximately 2360 rpm). This will give a 40 % saving on the absorbed power. The reduction in rotation speed of the motor consistently increases the life of the pump, due to the less stress it is subjected to.

Variation in pump performance in relation to speed variation

The number of "n" pump revolutions has a significant impact on the performance of the pump itself.

- The variation of the flow is proportional to the variation in the number of revolutions.
- The pressure variation follows a quadratic law in relation to the variation of the number of revolutions.
- The power follows a cubic law in relation to the variation of the number of revolutions.
- A small variation in the number of revolutions translates into an important variation of the power, with corresponding energy savings.

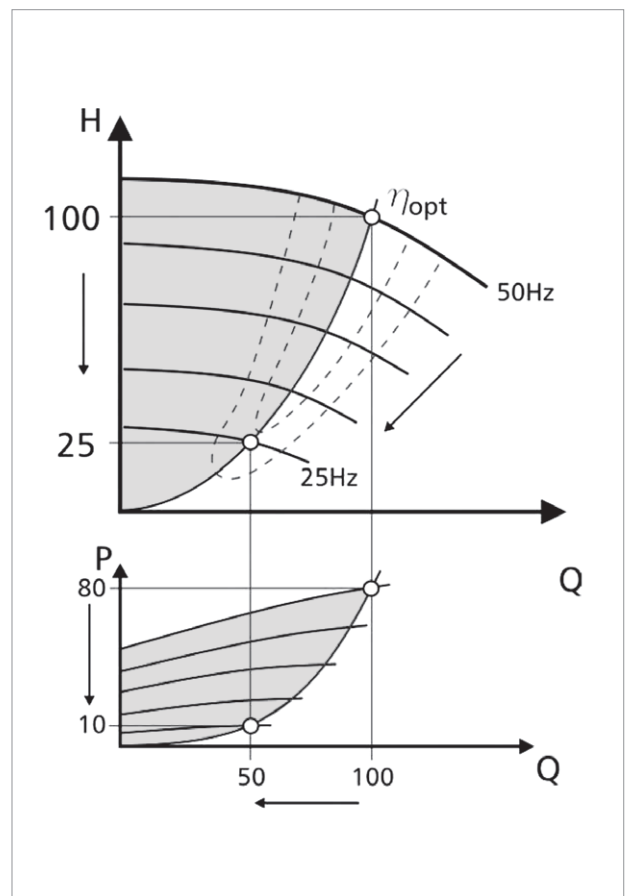

PERFORMANCE CURVES WITHOUT INVERTER

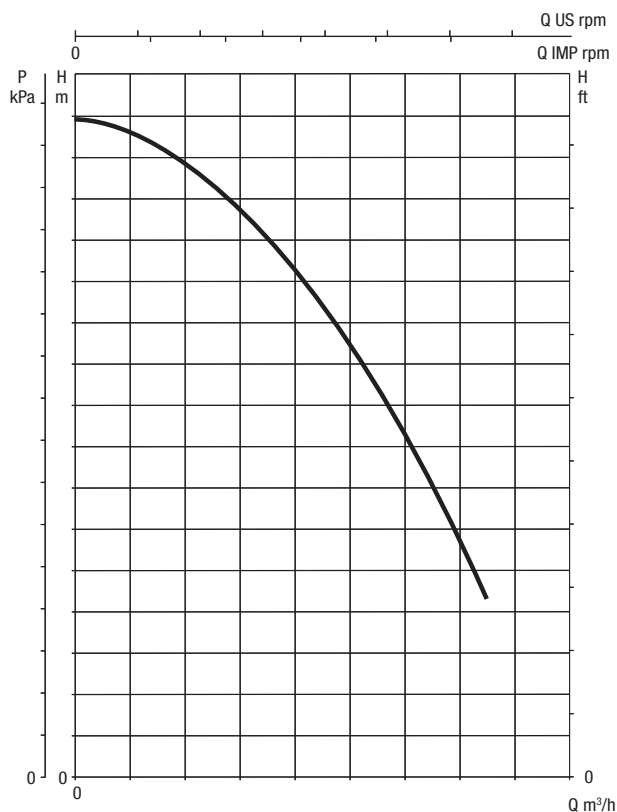

PERFORMANCE CURVES WITH INVERTER

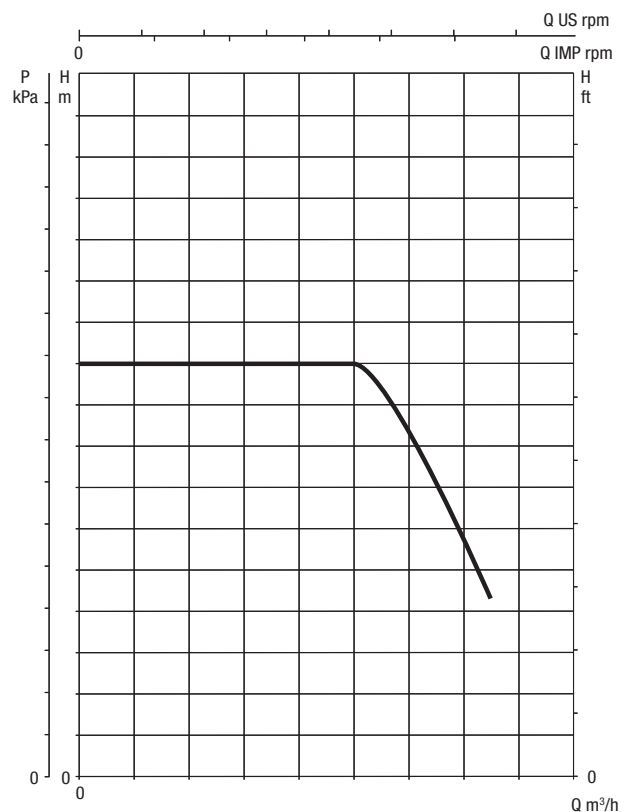

MOTOR CONNECTIONS

1 HYDRAULIC DIAGRAM

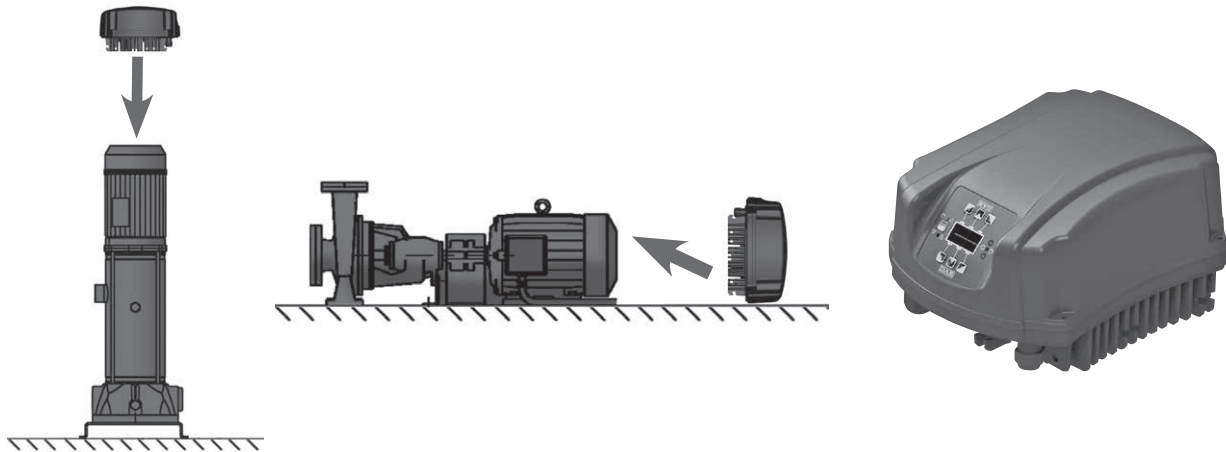

The MCE must be installed on the bottom of the motor.
 The inverter can operate both in the horizontal and the vertical position.
 2 different kits for assembly on the motor are available:

TIE RODS

They are attached to the MCE dissipator and the fan cover.

They require the fan cover to be well secured and capable of withstanding the weight of the inverter. This means that it must be fastened in position with bolts or screws.

FAN COVER KIT:

The fan cover kit must be used in all those cases when the fan cover is not well secure and sufficiently strong to withstand the weight of the inverter.

TWIN OPERATION

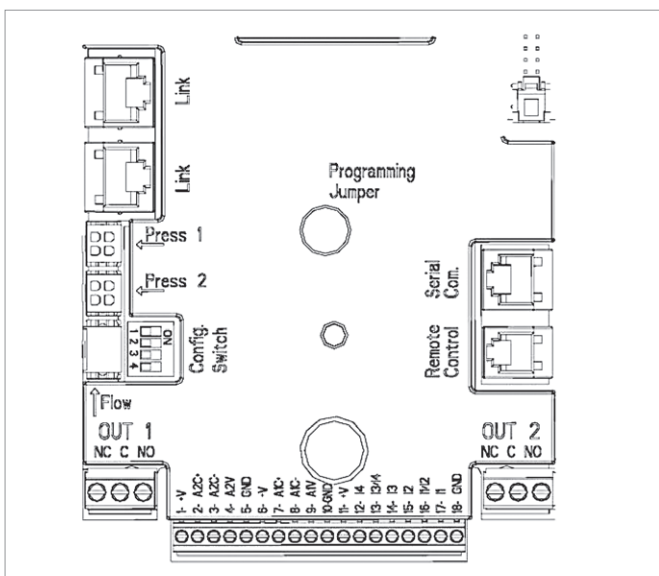

It is possible to create pumping groups with a maximum of 8 pumps. In order to do this, it is necessary to hydraulically connect the pumps on the same delivery and suction manifolds. For twin circulators, this operation is of course not necessary.

It is also necessary to connect the 2 MCE/P inverters using the appropriate interconnection cable, connected to both inverters, using one of the 2 connectors marked with Link.

For correct operation of the twin system, it is necessary that all the input terminal board external connections are connected in parallel between the 2 MCE/P, complying with the numerations of the individual terminals.



APPLICATIONS

The ADAC family represents the new frontier of Dab inverters. These inverters are intended for complex professional applications. They can pilot three-phase pumps up to 15 kW. They combine the simplicity of the ADAC series with the strength and power of the inverter. They are control panel devices, and must be equipped with pressure sensors. The latter guarantees improved pressure control. These models also permit the assembly of pressurisation units.

The ADAC family combines comfort and savings, includes all the protection features, and is easy to install and configure.

WHY SHOULD I CHOOSE A DAB INVERTER?

The ADAC models are air-cooled. These control box inverters are extremely strong, with a metal body, and suitable for heavy duty uses. In order to operate, they require a pressure sensor. A flow sensor can also be installed as optional. ADAC devices combine comfort with ease of installation and maintenance.

ADAC devices ensure maximum comfort and increase the average life of the system, also providing significant energy savings.

ADVANTAGES

- Easy to install in existing systems.
- Constant pressure.
- Up to 60% reduction in energy consumption.
- Built-in protections.
- Suitable for all pumps.
- Strong.
- Possibility of sets with interchange of up to 8 pumps.

MODEL	MAXIMUM PUMP MECHANICAL POWER (P2) KW	MAX MOTOR NOMINAL CURRENT A	MIN MOTOR NOMINAL CURRENT A	POWER INPUT 50 Hz	ELECTRIC PUMP POWER INPUT 50 - 200 Hz
AD M/T 1.0 AC	1,0	6,5	1	1x230	3x230
AD M/T 1.5 AC	1,5	9,0	1	1x230	3x230
AD M/T 2.2 AC	2,2	11,5	1	1x230	3x230
AD T/T 3.0 AC	3,0	9,0	2	3x400	3x400
AD T/T 4.0 AC	4,0	11	2	3x400	3x400
AD T/T 5.5 AC	5,5	15	2	3x400	3x400
AD T/T 7.5 AC	7,5	22	2	3x400	3x400
AD T/T 11.0 AC	11	31	2	3x400	3x400
AD T/T 15.0 AC	15	41	2	3x400	3x400

SIZES AND WEIGHTS

AD M/T 1.0 AC – AD M/T 1.5 AC AD M/T 2.2 AC

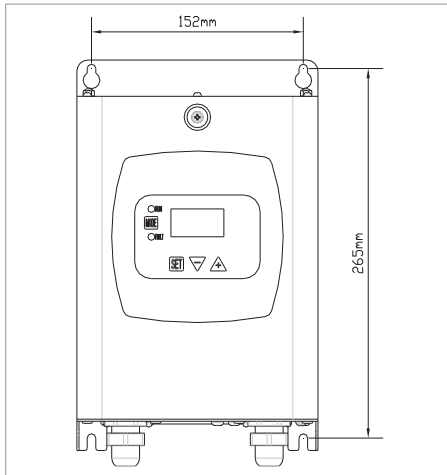

AD T/T 3.0 AC – AD T/T 4.0 AC AD T/T 5.5 AC

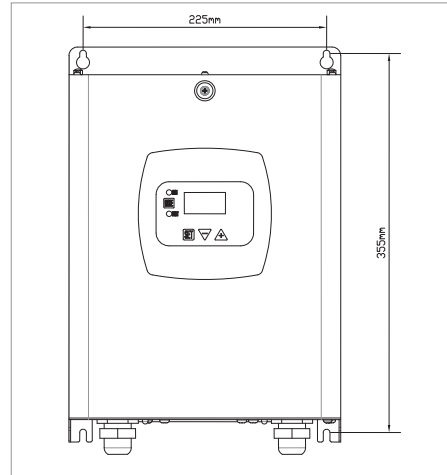

AD T/T 7.5 AC – AD T/T 11.0 AC AD T/T 15.0 AC

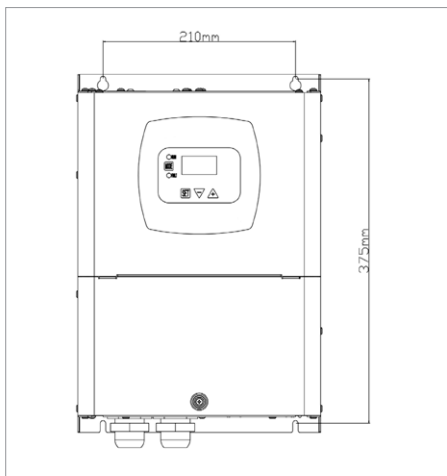

MODEL	L	H	D	PACKING DIMENSIONS			WEIGHT kg
				L/D	L/L	H	
AD M/T 1.0 AC	200	199	262	300	350	250	5
AD M/T 1.5 AC	200	199	262	300	350	250	5
AD M/T 2.2 AC	200	199	262	300	350	250	5
AD T/T 3.0 AC	267	196	352	350	570	250	7,6
AD T/T 4.0 AC	267	196	352	350	570	250	7,6
AD T/T 5.5 AC	267	196	352	350	570	250	7,6
AD T/T 7.5 AC	343	244	425	380	520	300	12
AD T/T 11.0 AC	343	244	425	380	520	300	12
AD T/T 15.0 AC	343	244	425	380	520	300	12

NOTES ON THE ADAC

The ADAC family represents the new frontier of DAB inverters. ADAC inverters are intended for complex professional applications. They can drive three phase electric pumps up of to 15 kW.

They combine the simplicity of the ADAC series with the strength and power of the inverter.

They are installed on a support frame, taking advantage of the motor cooling system.

The ADAC family combines comfort and savings, includes all the protection features, and is easy to install and configure.

ENERGY SAVING

Reducing, even for just one minute, the rotation speed of a motor, can bring significant energy savings, as the power consumed by an electric motor is proportional to the cube of the number of revolutions.

For example, a pump connected to the power network working at approximately 2950 rpm, if set to operate at 40 Hz, will turn at a speed approximately 20 % lower (approximately 2360 rpm). This will give a 40 % saving on the absorbed power. The reduction in rotation speed of the motor consistently increases the life of the pump, due to the less stress it is subjected to.

Variation in pump performance in relation to speed variation.

The number of "n" pump revolutions has a significant impact on the performance of the pump itself.

- The variation of the flow is proportional to the variation in the number of revolutions.
- The pressure variation follows a quadratic law in relation to the variation of the number of revolutions.
- The power follows a cubic law in relation to the variation of the number of revolutions.
- A small variation in the number of revolutions translates into an important variation of the power, with corresponding energy savings.

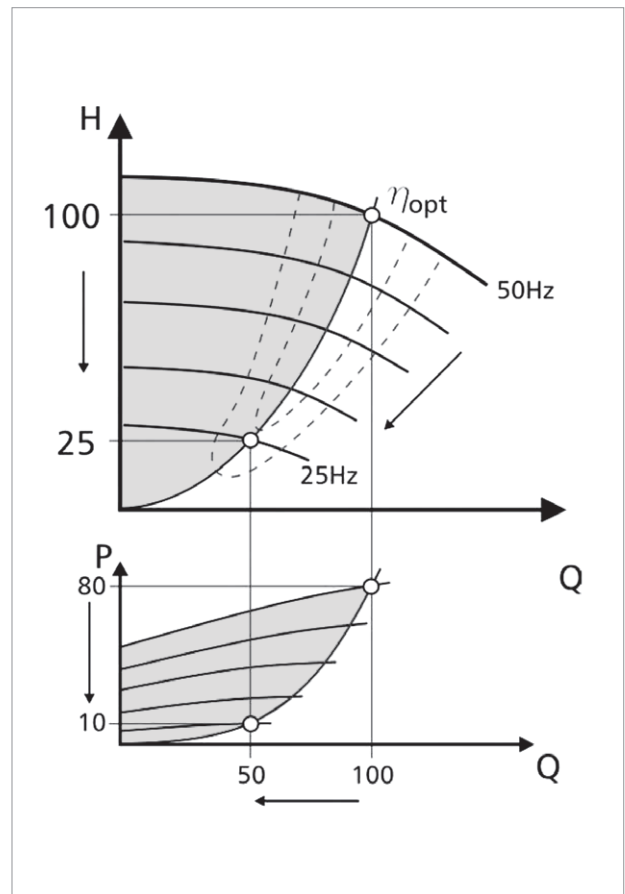

PERFORMANCE CURVES WITHOUT INVERTER

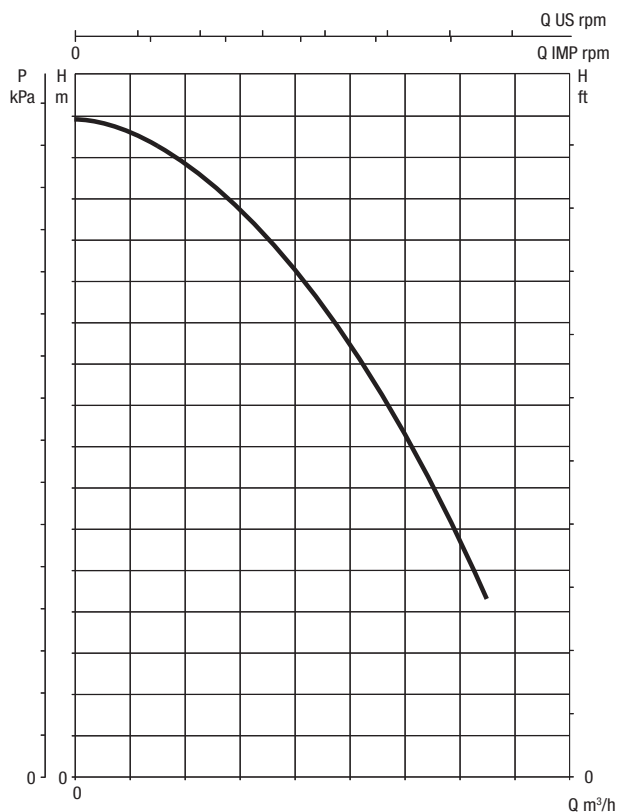

PERFORMANCE CURVES WITH INVERTER

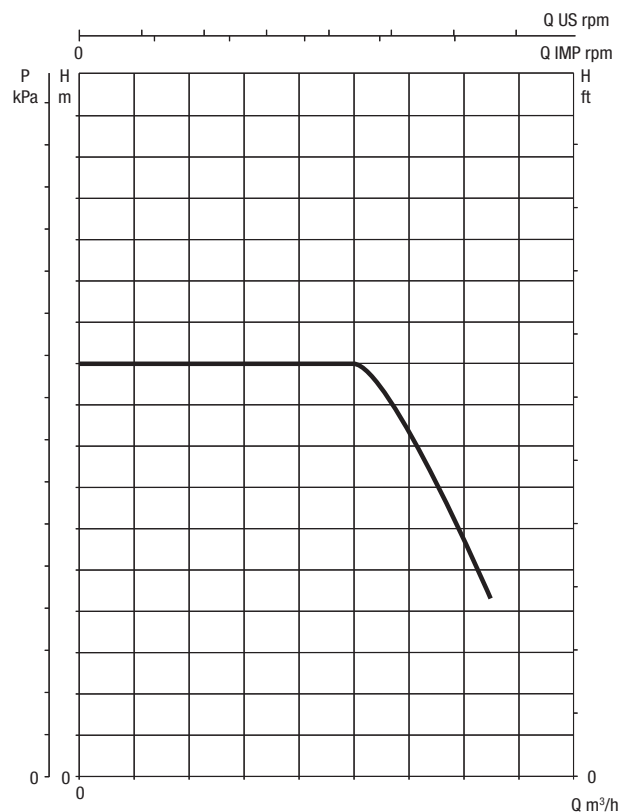



TECHNICAL DATA

Nominal power input voltage:

e.box plus 1x 230 V / 3 x 230 V - 3 x 400 V (automatic selection)

e.box basic 1x 230 V

Frequency: 50 - 60 Hz**Maximum power of use:**

e.box plus 5,5 kWatt + 5,5 kW

e.box basic 2,2 kWatt + 2,2 kW

Maximum current of use: 12 A + 12 A**Starting capacitor:** Supplied as accessory KIT**Ambient temperature operation limits:** -10 °C + 40 °C**Air relative humidity:** 90 % at 20 °C**Max. altitude:** 1000 a.s.l.**Protection class:** IP 55**Display:** 1,6" for e.box PLUS D and e.box BASIC D models

Standard of reference for the construction of the control panels EN

60335-1.

APPLICATIONS

E.box is an electronic control panel that provides all the functions and protections required for the installation of a pumping set for draining, filling, and pressurisation purposes.

E.BOX PLUS is an electric control panel for automatic protection and operation of one or more submersible electric pumps or pressure booster pumps, both single and three phase, for domestic, civil, and industrial applications. Thanks to the current regulation possibility, the e.box control panel is compatible with all pump models with current between 1 and 12 A, with power up to 5,5 kW.

E.BOX BASIC is an electric control panel for automatic protection and operation of one or more single phase submersible electric pumps or pressure booster pumps for domestic applications. The e.box control panel is compatible with all single phase pump models with current between 1 and 12 A, with power up to 2,2 kW, as indicated in the product compatibility table.

CONTROL PANEL CONSTRUCTION

Supplied in an IP 55 protection class self-extinguishing thermoplastic material box, the control panel protects the electric pumps from abnormal conditions such as: overload and overtemperature (with automatic reset), short circuit (with fuses - Plus model only), pump current surges (amperometric protection), abnormal voltage, dry run, quick starts, pressure sensor fault, or inconsistency of the external protection commands.

FRONT PANEL COMPONENTS

- General disconnecter with padlockable door lock.
- AUT-O-MAN operation selection pushbuttons.
- Alarm RESET pushbutton.
- Operation, stop, alarm notification lamps.
- Display, for PLUS D or BASIC D models.

PANEL INTERNAL COMPONENTS

- Electronic control card with protection fuses and contactors.
- Power input connection terminals, single phase (L-N in the Basic version), or three phase (L1-L2-L3 in the Plus version).
- Electric pump connection terminals, single phase (L-N in the BASIC version), or three phase (L1-L2-L3 in the PLUS version).
- Terminals for the connection of pressure switches, sensors, KK thermal protection, alarm notification N.O. contacts. Operation selection dip switch: level floats or sensor, tank filling and emptying, operation with one or two pumps also for the version with display.

SOFTWARE

For the models with display, the software

- During the first installation, provides step by step guidance in the selection of the correct settings based on the actual application.
- Makes the status of the control panel and the pumps clearly and immediately visible.
- When compared to the previous model, makes it easier to change the level settings, as operation of the control panel dip switch is no longer required.

ELECTRIC PROTECTION AND CONTROL PANELS

E.BOX

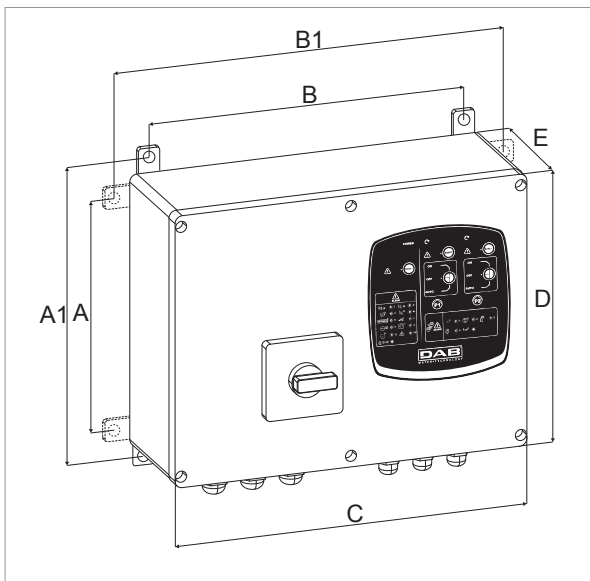

MODEL	A	A1	B	B1	C	D	E	PACKING DIMENSIONS			WEIGHT kg
								L/A	L/B	H	
E.BOX BASIC 230/50-60	212	265	282	337	320	260	120	250	430	310	4
E.BOX PLUS 230-400V/50-60	212	265	282	337	320	260	120	250	430	310	5
E.BOX BASIC D 230/50-60	212	265	282	337	320	260	120	250	430	310	4
E.BOX PLUS D 230-400V/50-60	212	265	282	337	320	260	120	250	430	310	5

MODEL	ELECTRICAL DATA					
	POWER INPUT 50 HZ	STARTING	P2 NOMINAL		MAX CURRENT A	DISPLAY
			kW x2	HP x2		
E.BOX BASIC 230/50-60	1X230 V~	direct	2,2	3	12+12	
E.BOX PLUS 230-400V/50-60	1X230 V~	direct	2,2	3	12+12	
	3X230 V~		3	4		
	3X400 V~		5,5	7,5		
E.BOX BASIC D 230/50-60	1X230 V~	direct	2,2	3	12+12	•
E.BOX PLUS D 230-400V/50-60	1X230 V~	direct	2,2	3	12+12	•
	3X230 V~		3	4		
	3X400 V~		5,5	7,5		

CONSTANT PRESSURE SETS

DRIVEN BY ELECTRIC CONTROL PANELS WITH INVERTER, SERIES EEGxx



EE 2G

APPLICATIONS

The sets with inverter have been designed and manufactured to meet the constant pressure requirements of modern system engineering solutions. The constant pressure adjustment is a requirement in the most varied sectors:

Water pipelines.
Irrigation.
Industry.
Hotels.
Residential building.
Spas.

The fundamental concept that has driven our Engineers in developing these pumps sets, was to offer a simple to use, flexible, and extremely reliable product.

Differently from traditional fixed speed pumps, inverter driven pumps give the possibility to adapt the performance curve to the needs of the system. In the most classic case, inverter driven pumps are used to maintain constant pressure in the system against variations in the requested flow rate, avoiding pressure fluctuations caused by small flow rate variations.

ADVANTAGES OF USE

Constant pressure.
Economic operation.
No hammering effects.
Less space requirements.
Less maintenance.
Reduction of power factor correction.
Reduction in water consumption.

CONSTRUCTION FEATURES

The sets with inverter consist of two or three centrifugal electric pumps, completely assembled on galvanised steel base, tested and ready for installation. Complete with isolator and check valves for each pump, galvanised steel suction and delivery manifolds, expansion vessels, pressure transducer, **electric control panel with inverter.**

ELECTRIC CONTROL PANEL WITH INVERTER

The inverter continuously adjusts the rotation speed of an electric pump, in order to maintain constant pressure despite changes in flow rate. The other fixed speed electric pumps are activated in cascade, once the inverter controlled electric pump has reached maximum speed. During this stage, the inverter controlled pumps operates in modulation, compensating for any system pressure variations.

At each operating cycle, the inverter control is switched to a different pump, so that the hours of operation are evenly distributed across all of the electric pumps.

CONSTANT PRESSURE SETS

INVERTER DRIVEN

TECHNICAL DATA - EE G CONTROL PANEL WITH INVERTER FOR 1 PUMP

MODEL	POWER INPUT 50 HZ	P2 NOMINAL		MAX PANEL CURRENT A	PANEL DIMENSIONS CM
		kW	HP		
EE G 2,2T	3 x 400 V	2,2	3	5,0	450x400x200
EE G 4T	3 x 400 V	4	5,5	9,0	450x400x250
EE G 5,5T	3 x 400 V	5,5	7,5	13	450x400x250
EE G 7,5T	3 x 400 V	7,5	10	16	450x400x250
EE G 11T	3 x 400 V	11	15	24	800x600x300
EE G 15T	3 x 400 V	15	20	30	800x600x300
EE G 18,5T	3 x 400 V	18,5	25	36	800x600x300
EE G 22T	3 x 400 V	22	30	42	1000x800x400
EE G 30T	3 x 400 V	30	40	58	1000x800x400

TECHNICAL DATA - EE G CONTROL PANEL WITH INVERTER FOR 2 PUMPS

MODEL	POWER INPUT 50 HZ	P2 NOMINAL		MAX PANEL CURRENT A	PANEL DIMENSIONS CM	2-3 PUMP START
		kW	HP			
EE2G 4,4T	3 x 400 V	2x2,2	2x3	2x5,0	450x400x200	DIRECT
EE2G 8T	3 x 400 V	2x4	2x5,5	2x9,0	450x400x250	
EE2G 11T	3 x 400 V	2x5,5	2x7,5	2x13	450x400x250	
EE2G 15T	3 x 400 V	2x7,5	2x10	2x16	450x400x250	
EE2G 22T SD	3 x 400 V	2x11	2x15	2x24	800x800x300	Y/Δ
EE2G 30T SD	3 x 400 V	2x15	2x20	2x30	800x800x300	
EE2G 37T SD	3 x 400 V	2x18,5	2x25	2x36	800x800x300	
EE2G 44T SD	3 x 400 V	2x22	2x30	2x42	1200x800x400	
EE2G 60T SD	3 x 400 V	2x30	2x40	2x58	1400x800x400	

TECHNICAL DATA - EE 3G CONTROL PANEL WITH INVERTER FOR 3 PUMPS

MODEL	POWER INPUT 50 HZ	P2 NOMINAL		MAX PANEL CURRENT A	PANEL DIMENSIONS CM	2-3 PUMP START
		kW	HP			
EE3G 6,6T	3 x 400 V	3x2,2	3x3	3x5,0	450x400x200	DIRECT
EE3G 12T	3 x 400 V	3x4	3x5,5	3x9,0	450x400x250	
EE3G 16,5T	3 x 400 V	3x5,5	3x7,5	3x13	450x400x250	
EE3G 22,5T	3 x 400 V	3x7,5	3x10	3x16	450x400x250	
EE3G 33T SD	3 x 400 V	3x11	3x15	3x24	800x800x300	Y/Δ
EE3G 45T SD	3 x 400 V	3x15	3x20	3x30	800x800x300	
EE3G 55,5T SD	3 x 400 V	3x18,5	3x25	3x36	800x800x300	
EE3G 66T SD	3 x 400 V	3x22	3x30	3x42	1600x800x400	
EE3G 90T SD	3 x 400 V	3x30	3x40	3x58	1600x800x400	

When selecting the control panel, ensure that the rated current (In) of the pump is less than the maximum current of the control panel.

CONSTANT PRESSURE SETS

INVERTER DRIVEN

OPERATION DIAGRAM INVERTER CONTROL PANEL OPERATION

The pressure transmitter reads the pressure on the delivery manifold and forwards it to the HYDROCONTROLLER control unit on the front of the panel. The manifold pressure is compared to the pressure set on HYDROCONTROLLER:

- if the pressure decreases, HYDROCONTROLLER forwards a 0-10 V signal to the inverter, which increases the speed of an electric pump;
 - if the pressure increases, HYDROCONTROLLER forwards a 0-10 V signal to the inverter, which decreases the speed of an electric pump.
- When the electric pump reaches maximum speed (2,900 rpm 50 Hz), HYDROCONTROLLER starts the other pumps at fixed speed. The inverter control is switched to the second / third pump at each system re-start.

In case of fault, the set is automatically switched to pressure switch operation.

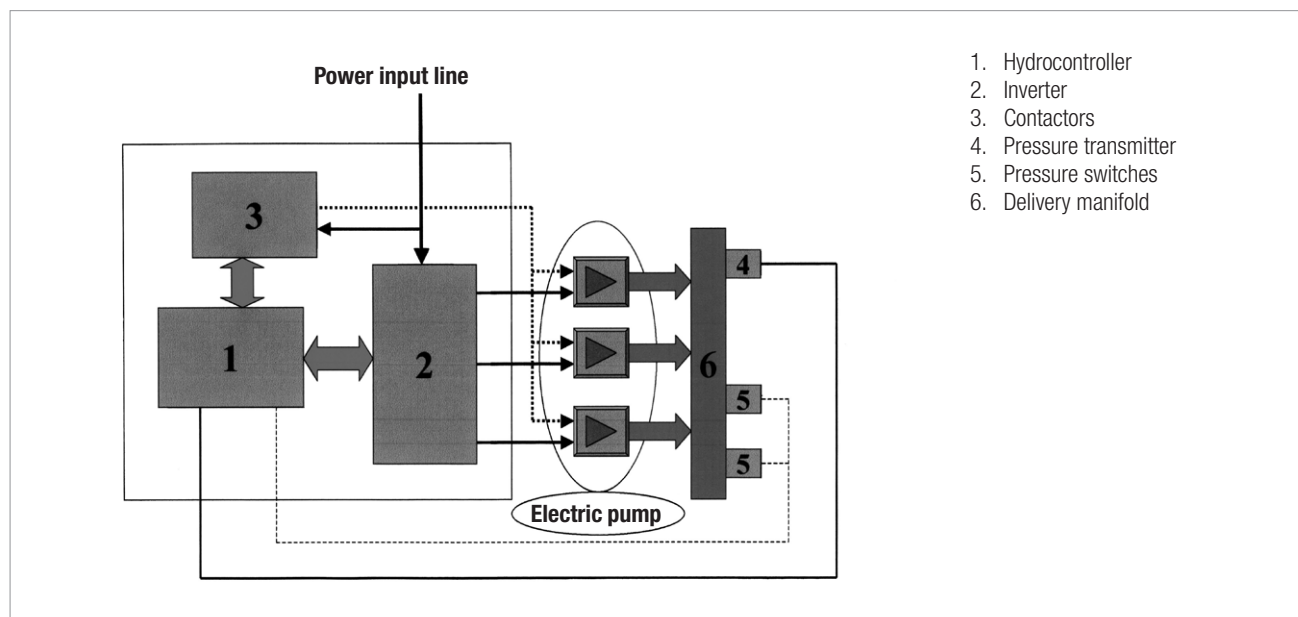

MODES OF OPERATION - TYPE OF SYSTEM

The inverter sets are already set at the factory for constant pressure operation. However, they can operate with different types of systems, by selecting the system type on the display.

- constant pressure booster systems (booster sets)

- 1) Constant pressure regulation with **internal PSET**.
It is set on the display of the electric control panel (unit of measure BAR)
- 2) Constant relative pressure regulation with **external PSET**.
It is set using an external potentiometer (unit of measure BAR).

- Constant differential pressure systems (close circuits - circulation type).

- Constant differential pressure regulation with internal PSET.
It is set on the display of the electric control panel (unit of measure METRES)
Operation of one pump at the time, switching the starting order every 24 hours.
Automatic pump switch in case of seizing of the currently operating pump.
- 2) Constant differential or relative pressure regulation with external PSET.
It is set using an external potentiometer (unit of measure METRES).

CONTROL PANEL CHARACTERISTICS

IP 55 metal box electric control panel, installed on the pump base.

The control box is self-protected and it protects the electric pump from overloads, short circuits, and low pump delivery pressure.

The electric control panel is ready for the connection of:

RS 485 output for the control and supervision of the set using a Personal Computer (*).

- Dry run stop float or pressure switch kit (*).
- Overpressure stop pressure switch kit (*).

(*) available separately as optional.

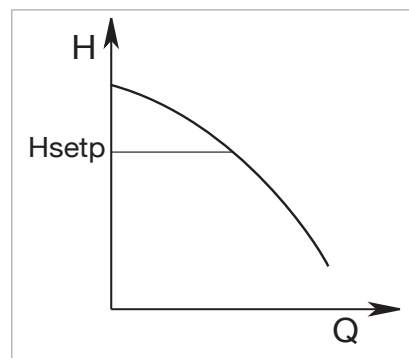

CONSTANT PRESSURE SETS

INVERTER DRIVEN

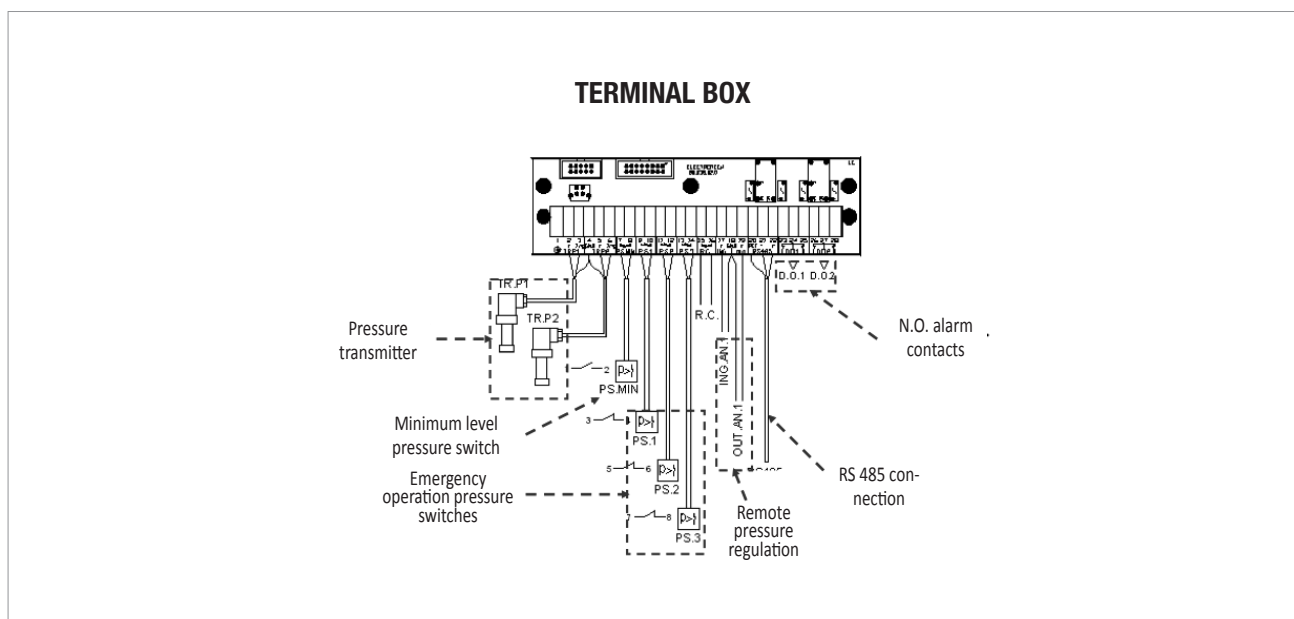

CONNECTION TERMINAL REFERENCES

Terminal references	Operation
TRP1 1 - 2 - 3	pressure transducer ONE connection terminals. Terminal ref. 1 = \oplus , 2 = power input 3= inp.
TRP2 1 - 4 - 5 - 6	pressure transducer TWO connection terminals. Terminal ref. 1 = \oplus , 4 = GND, 5 = power input, 6= inp. 2.
P.S. MIN. 7 - 8	Minimum pressure transducer connection terminals (only connect voltage-free contacts)
P.S. 1. 9 - 10	Electric pump ONE control pressure switch connection terminals. (only connect voltage-free contacts)
P.S. 2. 11 - 12	Electric pump TWO control pressure switch connection terminals. (only connect voltage-free contacts)
P.S. 3. 13 - 14	Electric pump THREE control pressure switch connection terminals. (only connect voltage-free contacts)
R. C. 15 - 16	Terminals for the connection of a configurable remote control. 15= ing., 16=power input. (only connect voltage-free contacts)
ING. 17 - 18 - 5	PSET EXT. potentiometer connection terminals. Terminal ref. 17=ING, 18=GND, 5= power input. (connect 10 k-ohm 1 W potentiometers)
OUT. 18 - 19	External device connection terminals. Terminal ref. 18=GND, 19= OUT. (connect devices with maximum absorption 5 mA, 10 V).
RS485 20 - 21 - 22	RS 485 serial remote communication connection terminals. Terminal ref. 20=REF, 21=D+, 22=D-
23 - 24 25 (D.O. 1)	Remote alarm contact connection terminals. Terminal ref. 23=NC, 24=COM. 25=NA. with control panel not powered or in alarm. (voltage-free contacts. Characteristic 250 V ac 5 A).
26 - 27 - 28 (D.O. 2)	Remote menu set function notification contact connection terminals. Terminal ref. 26=NC, 27=COM. 28=NA. with control panel not powered or in alarm. (voltage-free contacts. Characteristic 250 V ac 5 A).

CONSTANT PRESSURE SETS

INVERTER DRIVEN



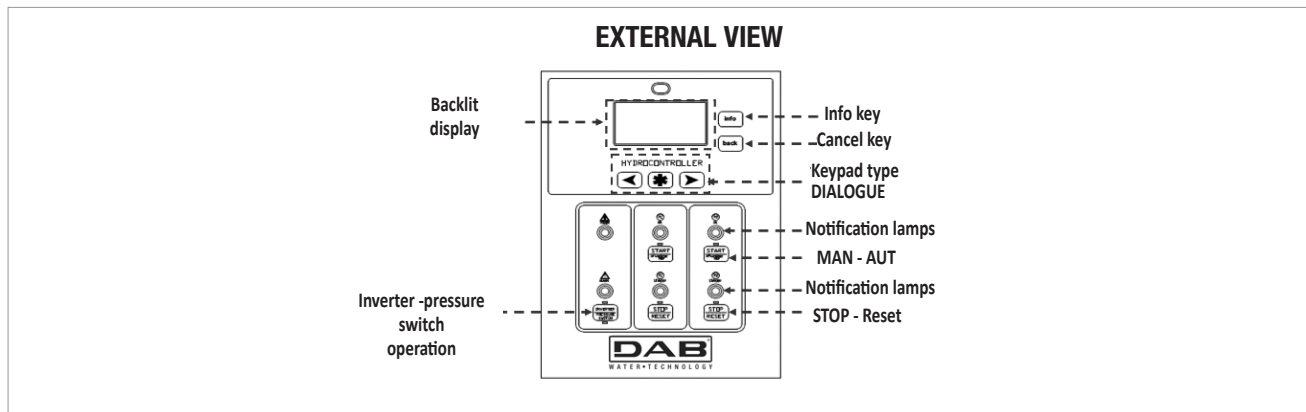

PANEL FRONT DISPLAYS



Video screen	Description
<p style="text-align: center;">HOME PAGE</p> <p style="text-align: center;">HOME PAGE</p>	<p>The "HOME PAGE" offer a graphic summary of the main settings of the inverter control panel.</p> <ul style="list-style-type: none"> - p = instantaneous system pressure. - constant pressure system - = pump power input example: P1 powered by inverter, P2 powered by the mains, P3 OFF - F = frequency of the inverter powered pump. - = menu/keypad block/release. - = access to the next parameter. - = access to the LCD contrast adjustment. - = e.g. alarm 16, inverter blocked and pressure switch system operation. <p>Electric pump status legend:</p> <ul style="list-style-type: none"> - = electric pump powered by inverter. - = electric pump powered by the mains. - = electric pump operation inhibited. - = electric pump in stand-by ready for operation. - = electric pump blocked and all operation inhibited. - = electric pump manually powered by the operator.
<p style="text-align: center;">Page 02</p>	<p>The "HOME PAGE" offers a graphic summary of the main settings of the inverter control panel.</p> <p>System electrical parameter display page.</p> <ul style="list-style-type: none"> - V = control panel power input voltage. - It = Total current absorbed by the system. - Pt = instantaneous power absorbed by the system. - E = Total energy absorbed by the system. <p>This parameter is updated every time that the hours of maintenance are reset.</p>
<p style="text-align: center;">HOME PAGE</p>	<p>Hours of operation of the pumps.</p> <p>Page displaying the total hours of operation of the motors.</p> <p>Alarm reset AL1 indicated in the monitor page (pump maintenance request) must be carried out by pressing the STOP pushbutton of the corresponding pump in maintenance for more than 3 seconds.</p>

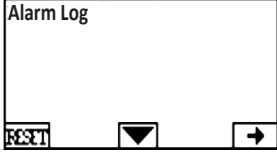
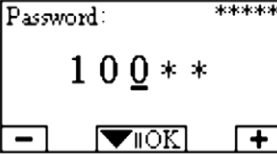

CONSTANT PRESSURE SETS

INVERTER DRIVEN

<p>Page 02</p> 	<p>Alarm log page display. Alarms are showed in decreasing order, from the most recent to the oldest.</p>
<p>Page 05</p> 	<p>PASSWORD entering page.</p> <ul style="list-style-type: none"> - The page display 5 zeros, corresponding to the 5 password digits to enter. User password: enter 10009 - Press SB10  to select the first digit to enter. - Use the same key SB10  to enter the digits of the selected password. After entering the password, check that it is correct and press SB9  to confirm the selection. <p>After entering the password, check that it is correct and press SB9  to confirm the entire password and go to the parameter set-up pages.</p>



HOW TO ACCESS THE CONTROL MENU

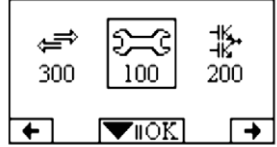

- Press **SB1** and stop the system;
- Press **SB8** (in relation to the symbol ) the display turns on, and access to the subsequent pages is possible.
- Press **SB9**  until the subsequent menu pages are displayed.

PARAMETER CONFIGURATION

	<p>It is possible to access the various parameters using password 10009.</p> <p>To go to the next parameter use the keys under the corresponding arrows on the display.</p>
---	---

	Adjustment field	Default settings
	<p>[100] Language Menu language: 1) Italian 2) English 3) French 4) German 5) Spanish</p>	<p>Italian</p>
	<p>[109] Offsetting of load losses Automatic increase of the bar pressure of reference, for the activation of the pumps in cascade.</p>	<p>It depends on the type of set.</p>

CONSTANT PRESSURE SETS

INVERTER DRIVEN

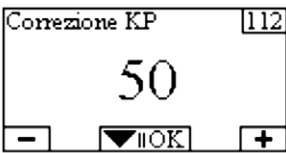
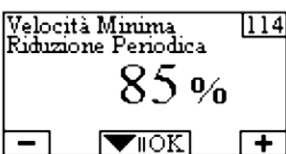
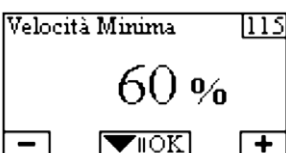
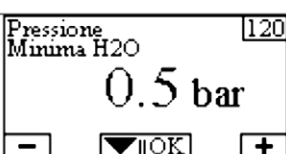
	<p>[111] Reference pressure 1 Bar pressure set point to be kept constant.</p>	<p>0,0 – 25,0 BAR</p>	<p>It depends on the type of set.</p>
	<p>[112] KP correction Instantaneous correction of the system instantaneous pressure error and reference pressure.</p>	<p>0 - 250</p>	<p>50</p>
	<p>[114] Minimum speed Periodic Reduction Minimum speed % Set below which stopping of the inverter-driven pump is enabled.</p>	<p>0 - 100 %</p>	<p>90.00 %</p>
	<p>[115] Minimum speed Inverter speed % Set to enable stopping of pumps in cascade.</p>	<p>0 - 100 %</p>	<p>60.00 %</p>
	<p>[120] Minimum Water Column Pressure Pressure Set to enter on the basis of the water column pressure on the dis charge port.</p>	<p>0,0 – 2,0 bar</p>	<p>0.5 bar</p>

TROUBLESHOOTING: ALARM DISPLAY

Alarms are indicated on the display by means of a numerical code.
The alarms are shown in sequence from the most recent to the oldest.

Error condition		
Display indication	Description	Reset
AL4	Transducer connections interrupted or inverted.	- Check the electrical connections and that the transducer is working correctly.
AL8	Pumps jammed, motor phase missing Ampere scale calibration error	- Release the pump manually. - Check the motor fuses.
AL16	Inverter protection. Alarm Code List FC51 shown on page 29 of the inverter handbook.	- Disconnect the power input voltage from the control panel. - Wait 5 minutes and then reconnect the power input. - If the error continues replace the inverter.
AL32	Overpressure	- Stop the system. Check that parameter 124 is set correctly.
AH20	Minimum pressure	- Check that the system is full of water. - Enable the start of the electric pumps.
AL64	No water.	- Check that the system is full of water. - Enable the start of the electric pumps.



DNA
PUMPS SELECTOR

On-line product selection



DAB PUMPS LTD.

Unit 4 and 5, Stortford Hall Industrial Park,
Dunmow Road,
Bishops Stortford,
Herts
CM23 5GZ - UK
salesuk@dwtgroup.com
Tel. +44 1279 652 776
Fax +44 1279 657 727



DAB PUMPS IBERICA S.L.

Avenida de Castilla nr.1 Local 14
28830 - San Fernando De Henares - Madrid
Spain
info.spain@dwtgroup.com
Tel. +34 91 6569545
Fax: +34 91 6569676



DAB PUMPS INC.

3226 Benchmark Drive
Ladson, SC 29456 - USA
info.usa@dwtgroup.com
Tel. 1-843-824-6332
Toll Free 1-866-896-4DAB (4322)
Fax 1-843-797-3366



DAB PUMPS B.V.

Brusselstraat 150
B-1702 Groot-Bijgaarden - Belgium
info.belgium@dwtgroup.com
Tel. +32 2 4668353
Fax +32 2 4669218



DAB PRODUCTION HUNGARY KFT.

H-8800
Nagykanizsa, Buda Ernő u.5
Hungary
Tel. +36 93501700



DWT SOUTH AFRICA

Podium at Menlyn,
3rd Floor, Unit 3001b, 43 Ingersol Road,
C/O Lois and Atterbury street,
Menlyn, Pretoria, 0181 - South-Africa
info.sa@dwtgroup.com
Tel. +27 12 361 3997
Fax +27 12 361 3137



DAB PUMPS B.V.

Albert Einsteinweg, 4
5151 DL Drunen - Nederland
info.netherlands@dwtgroup.com
Tel. +31 416 387280
Fax +31 416 387299



DAB PUMPS POLAND Sp. z o.o.

Mokotów Marynarska
ul. Postępu 15C
02-676 Warszawa - Poland
polska@dabpumps.com.pl
Tel. +48 223 816 085



DAB PUMPS CHINA

No.40 Kaituo Road, Qingdao Economic & Technological
Development Zone
Qingdao City, Shandong Province - China
PC: 266500
info.china@dwtgroup.com
Tel. +8653286812030-6270
Fax +8653286812210



DAB UKRAINE Representative Office

Regus Horizon Park
4 M. Hrinchenka St, suit 147
03680 Kiev - Ukraine
Tel. +38 044 391 59 43



DAB PUMPEN DEUTSCHLAND GmbH

Tackweg 11
D - 47918 Tönisvorst - Germany
info.germany@dwtgroup.com
Tel. +49 2151 82136-0
Fax +49 2151 82136-36



OOO DAB PUMPS

Novgorodskaya str. 1, block G
office 308, 127247, Moscow - Russia
info.russia@dwtgroup.com
Tel. +7 495 122 0035
Fax +7 495 122 0036



DAB PUMPS DE MÉXICO, S.A. DE C.V.

Av Gral Álvaro Obregón 270, oficina 355
Hipódromo, Cuauhtémoc 06100
México, D.F.
Tel. +52 55 6719 0493